



## Module-1

### Introduction:

A system is an arrangement of or a combination of different physical components connected or related in such a manner so as to form an entire unit to attain a certain objective.

Control system is an arrangement of different physical elements connected in such a manner so as to regulate, director command itself to achieve a certain objective

Any control system consists of three essential components namely input, system and output. The input is the stimulus or excitation applied to a system from an external energy source. A system is the arrangement of physical components and output is the actual response obtained from the system. The control system may be one of the following type.

- 1) man made
- 2) natural and / or biological and
- 3) hybrid consisting of man made and natural or biological.

Requirements of good control system are accuracy, sensitivity, noise, stability, bandwidth, speed, oscillations

#### Types of control systems

Control systems are classified into two general categories based upon the control action which is responsible to activate the system to produce the output viz.

- 1) Open loop control system in which the control action is independent of the out put.
- 2) Closed loop control system in which the control action is some how dependent upon the output and are generally called as feedback control systems.

### Open Loop System

It is a system in which control action is independent of output. To each reference input there is a corresponding output which depends upon the system and its operating conditions. The



accuracy of the system depends on the calibration of the system. In the presence of noise or disturbances open loop control will not perform satisfactorily.

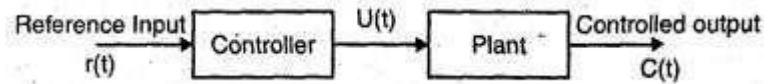

Example: Automatic hand driver, automatic washing machine, bread toaster, electric lift, traffic signals, coffee server, theatre lamp etc.

#### Advantages of open loop system:

1. They are simple in construction and design.
2. They are economic.
3. Easy for maintenance.
4. Not much problem of stability.
5. Convenient to use when output is difficult to measure.

#### Disadvantages of open loop system

1. Inaccurate and unreliable because accuracy is dependent on accuracy of calibration.
2. Inaccurate results are obtained with parameter variations, internal disturbances.
3. To maintain quality and accuracy, recalibration of controller is necessary from time to time.

### 1.3.A closed loop control system:

Is a system in which the control action depends on the output. In closed loop control system the actuating error signal, which is the difference between the input signal and the feed back signal (output signal or its function) is fed to the controller.

The elements of closed loop system are command, reference input, error detector, control element controlled system and feedback element.

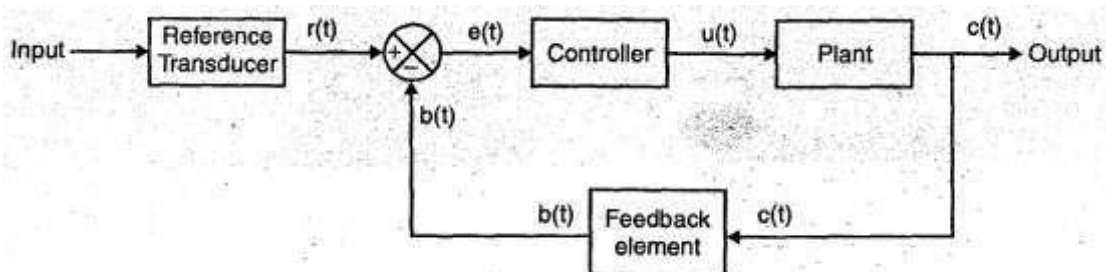

#### Elements of closed loop system are:

1. **Command** : The command is the externally produced input and independent of the feedback control system.
2. **Reference Input Element**: It is used to produce the standard signals proportional to the command.
3. **Error Detector** : The error detector receives the measured signal and compare it with reference input. The difference of two signals produces error signal.
4. **Control Element** : This regulates the output according to the signal obtained from error detector.
5. **Controlled System** : This represents what we are controlling by feedback loop.



- 6. Feedback Element :** This element feedback the output to the error detector for comparison with the reference input.

**Example:** Automatic electric iron, servo voltage stabilizer, sun-seeker solar system, water level controller, human perspiration system.

#### **Advantages of closed loop system:**

1. Accuracy is very high as any error arising is corrected.
2. It senses changes -in output due to environmental or parametric change, internal disturbance etc. and corrects the same.
3. Reduce effect of non-linearities.
4. High bandwidth.
5. Facilitates automation.

#### **Disadvantages**

1. Complicated in design and maintenance costlier.
2. System may become unstable.

#### **Concepts of feedback:**

Feedback system is that in which part of output is feeded back to input. In feedback system corrective action starts only after the output has been affected.

#### **Requirements of good control system :**

Requirements of good control system are,

1. Accuracy
2. Sensitivity
3. Noise
4. Stability
5. Bandwidth
6. Speed
7. Oscillations

#### **Types of controllers:**

An automatic controller compares the actual value of the system output with the reference input (desired value), determines the deviation, and produces a control signal that will reduce the deviation to zero or a small value. The manner in which the automatic controller produces the control signal is called the control action. The controllers may be classified according to their control actions as,

1. Proportional controllers.
2. Integral controllers.
3. Proportional-plus- integral controllers.
4. Proportional-plus-derivative controllers.
5. Proportional-plus- integral-plus-derivative controllers



**A proportional control system** is a feedback control system in which the output forcing function is directly proportional to error.

**A integral control system** is a feedback control system in which the output forcing function is directly proportional to the first time integral of error.

**A proportional-plus-derivative control system** is a feedback control system in which the output forcing function is a linear combination of the error and its first time derivative.

**A proportional-plus- integral control system** is a feedback control system in which the output forcing function is a linear combination of the error and its first time integral.

**A proportional-plus-derivative-plus- integral control system** is a feedback control system in which the output forcing function is a linear combination of the error, its first time derivative and its first time integral.

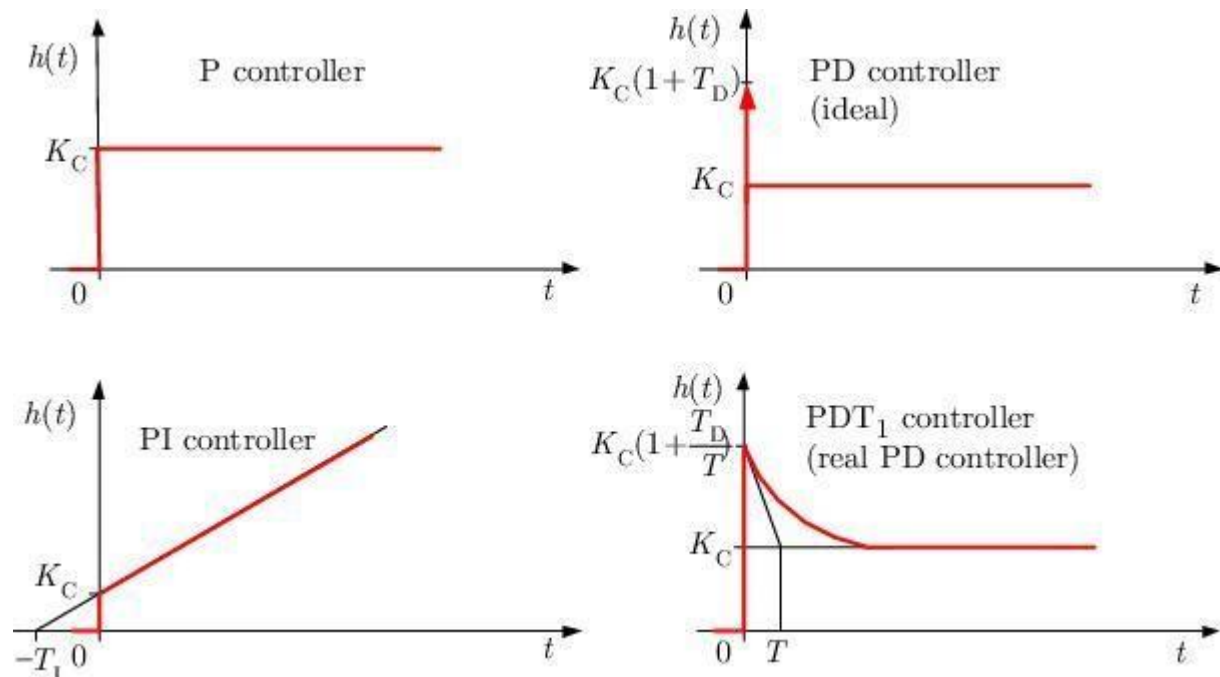

## OUTCOMES:

At the end of the unit, the students are able to:

- Different types of control system.
- Different types of controllers.
- Ideal requirements of a good control system.

## SELF-TEST QUESTIONS:

1. Name three applications of control systems.
2. Give three examples of open- loop systems.
3. Explain open loop control system.
4. Explain Closed loop control system.
5. Describe the requirements of ideal control system.
6. Explain controllers in a control system.
7. Explain Proportional controllers.



S J P N Trust's

**Hirasugar Institute of Technology, Nidasoshi.**

*Inculcating Values, Promoting Prosperity*

Approved by AICTE, Recognized by Govt. of Karnataka and Affiliated to VTU Belagavi.

**Mechanical**

**Academic**

**Notes**

**Control Engineering-  
15ME73**

8. Explain Integral Proportional Integral controllers.



S J P N Trust's

**Hirasugar Institute of Technology, Nidasoshi.**

*Inculcating Values, Promoting Prosperity*

Approved by AICTE, Recognized by Govt. of Karnataka and Affiliated to VTU Belagavi.

**Mechanical**

**Academic**

**Notes**

**Control Engineering-  
15ME73**

9. Explain Proportional Integral Differential controllers.

**FURTHER READING:**

1. **Modern Control Systems**, Richard.C.Dorf and Robert.H.Bishop, Addison Wesley, 1999
2. **System dynamics & control**, Eronini-Umez, Thomson Asia pte Ltd. singapore, 2002.
3. **Feedback Control System**, Schaum's series. 2001.

**Module-  
2****MATHEMATICAL MODELS****LESSON STRUCTURE:****Modeling of Control Systems****Modeling of Mechanical Systems****Mathematical Modeling of Electrical System****Force Voltage Analogy****Force Current Analogy****OBJECTIVES:**

To develop mathematical model for the mechanical, electrical, servo mechanism and hydraulic systems.

**Modeling of Control Systems:**

The first step in the design and the analysis of control system is to build physical and mathematical models. A control system being a collection of several physical systems (sub systems) which may be of mechanical, electrical electronic, thermal, hydraulic or pneumatic type. No physical system can be represented in its full intricacies. Idealizing assumptions are always made for the purpose of analysis and synthesis. An idealized representation of physical system is called a Physical Model.

Control systems being dynamic systems in nature require a quantitative mathematical description of the system for analysis. *This process of obtaining the desired mathematical description of the system is called Mathematical Modeling.*

In Unit 1, we have learnt the basic concepts of control systems such as open loop and feedback control systems, different types of Control systems like regulator systems, follow-up systems and servo mechanisms. We have also discussed a few simple applications. In this chapter we learn the concepts of modeling.

The requirements demanded by every control system are many and depend on the system under consideration. Major requirements are 1) Stability 2) Accuracy and 3) Speed of Response. An ideal control system would be stable, would provide absolute accuracy (maintain zero error despite disturbances) and would respond instantaneously to a change in the reference variable. Such a system cannot, of course, be produced. However, study of automatic control system theory would provide the insight necessary to make the most effective compromises so that the engineer can design the best possible system. One of the important steps in the study of control systems is modeling. Following section presents modeling aspects of various systems that find application in control engineering.

The basic models of dynamic physical systems are differential equations obtained by the application of appropriate laws of nature. Having obtained the differential equations and where



S J P N Trust's

# Hirasugar Institute of Technology, Nidasoshi.

*Inculcating Values, Promoting Prosperity*

Approved by AICTE, Recognized by Govt. of Karnataka and Affiliated to VTU Belagavi.

**Mechanical**

**Academic**

**Notes**

**Control Engineering-  
15ME73**

possible the numerical values of parameters, one can proceed with the analysis. When the





mathematical model of a physical system is solved for various input conditions, the results represent the dynamic response of the system. The mathematical model of a system is linear, if it obeys the principle of *superposition and homogeneity*.

A mathematical model is *linear*, if the differential equation describing it has coefficients, which are either functions of the independent variable or are constants. If the coefficients of the describing differential equations are functions of time (the independent variable), then the mathematical model is *linear time-varying*. On the other hand, if the coefficients of the describing differential equations are constants, the model is *linear time-invariant*. Powerful mathematical tools like the Fourier and Laplace transformations are available for use in linear systems. Unfortunately no physical system in nature is perfectly linear. Therefore certain assumptions must always be made to get a linear model.

Usually control systems are complex. As a first approximation a simplified model is built to get a general feeling for the solution. However, improved model which can give better accuracy can then be obtained for a complete analysis. Compromise has to be made between simplicity of the model and accuracy. It is difficult to consider all the details for mathematical analysis. Only most important features are considered to predict behavior of the system under specified conditions. A more complete model may be then built for complete analysis.

### **Modeling of Mechanical Systems:**

Mechanical systems can be idealized as spring- mass-damper systems and the governing differential equations can be obtained on the basis of Newton's second law of motion, which states that

$$F = ma: \text{ for rectilinear motion}$$

where F: Force, m: mass and a: acceleration (with consistent units)

$$T = I \alpha: \text{ or } J\alpha \text{ for rotary motion}$$

where T: Torque, I or J: moment of inertia and  $\alpha$ : angular acceleration (with consistent units)

Mass / inertia and the springs are the energy storage elements where in energy can be stored and retrieved without loss and hence referred as conservative elements. Damper represents the energy loss (energy absorption) in the system and hence is referred as dissipative element. Depending upon the choice of variables and the coordinate system, a given physical model may lead to different mathematical models. The minimum number of independent coordinates required to determine completely the positions of all parts of a system at any instant of time defines the degrees of freedom (DOF) of the system. A large number of practical systems can be described using a finite number of degrees of freedom and are referred as discrete or lumped parameter systems. Some systems, especially those involving continuous elastic members, have an infinite number of degrees of freedom and are referred as continuous or distributed systems. Most of the time, continuous systems are approximated as discrete systems, and solutions are obtained in a simpler manner. Although treatment of a system as continuous gives exact results, the analysis methods available for



S J P N Trust's

**Hirasugar Institute of Technology, Nidasoshi.**

*Inculcating Values, Promoting Prosperity*

Approved by AICTE, Recognized by Govt. of Karnataka and Affiliated to VTU Belagavi.

**Mechanical**

**Academic**

**Notes**

**Control Engineering-  
15ME73**

dealing with continuous systems are limited to a narrow selection of problems. Hence most of the



practical systems are studied by treating them as finite lumped masses, springs and dampers. In general, more accurate results are obtained by increasing the number of masses, springs and dampers-that is, by increasing the number of degrees of freedom.

Mechanical systems can be of two types:

- 1) Translation Systems
- 2) Rotational Systems.

The variables that described the motion are displacement, velocity and acceleration.

And also we have three parameters-

- Mass which is represented by 'M'.
- Coefficient of viscous friction which is represented by 'B'.
- Spring constant which is represented by 'K'.

In rotational mechanical type of systems we have three variables-

- Torque which is represented by 'T'.
- Angular velocity which is represented by ' $\omega$ '
- Angular displacement represented by ' $\theta$ '

Now let us consider the linear displacement mechanical system which is shown below-

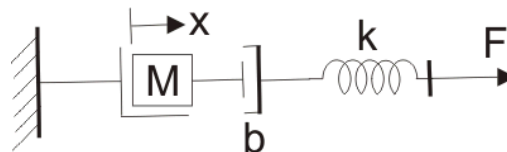

spring mass mechanical system

We have already marked various variables in the diagram itself. We have x is the displacement as shown in the diagram. From the Newton's second law of motion, we can write force as

$$F_1 = M \frac{d^2x}{dt^2} + B \frac{dx}{dt} + Kx$$
$$F_2 = B \frac{dx}{dt}$$
$$F_3 = Kx$$

From the diagram we can see that the,

$$F = F_1 + F_2 + F_3$$

On substituting the values of  $F_1$ ,  $F_2$  and  $F_3$  in the above equation and taking the Laplace transform we have the transfer function as,

$$T = \frac{1}{Ms^2 + Bs + K}$$



## Mathematical Modeling of Electrical System:

In electrical type of systems we have three variables -

- Voltage which is represented by 'V'.
- Current which is represented by 'I'.
- Charge which is represented by 'Q'.

And also we have three parameters which are active and passive elements –

- Resistance which is represented by 'R'.
- Capacitance which is represented by 'C'.
- Inductance which is represented by 'L'.

Now we are in condition to derive analogy between electrical and mechanical types of systems. There are two types of analogies and they are written below:

### Force Voltage Analogy :

In order to understand this type of analogy, let us consider a circuit which consists of series combination of resistor, inductor and capacitor.

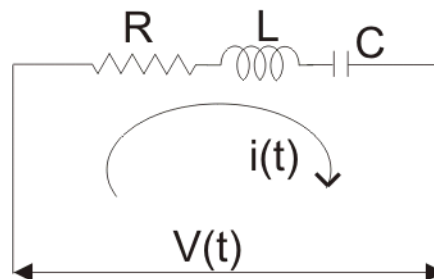

A voltage  $V$  is connected in series with these elements as shown in the circuit diagram. Now from the circuit diagram and with the help of KVL equation we write the expression for voltage in terms of charge, resistance, capacitor and inductor as,

$$V = L \frac{d^2q}{dt^2} + R \frac{dq}{dt} + \frac{q}{C}$$

Now comparing the above with that we have derived for the mechanical system we find that-

1. Mass (M) is analogous to inductance (L).
2. Force is analogous to voltage  $V$ .
3. Displacement ( $x$ ) is analogous to charge (Q).
4. Coefficient of friction (B) is analogous to resistance R and
5. Spring constant is analogous to inverse of the capacitor (C).

This analogy is known as force voltage analogy.

### Force Current Analogy :

In order to understand this type of analogy, let us consider a circuit which consists of parallel combination of resistor, inductor and capacitor.

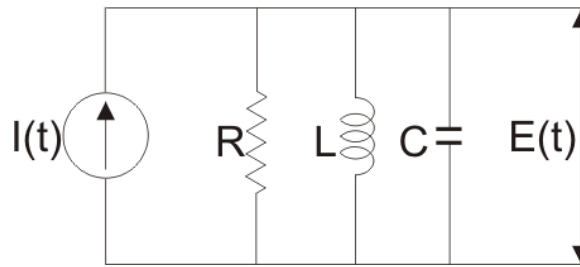

A voltage  $E$  is connected in parallel with these elements as shown in the circuit diagram. Now from the circuit diagram and with the help of KCL equation we write the expression for current in terms of flux, resistance, capacitor and inductor as,

$$I = C \frac{d^2\psi}{dt^2} + \frac{1}{R} \frac{d\psi}{dt} + \frac{\psi}{L}$$

Now comparing the above with that we have derived for the mechanical system we find that,

1. Mass ( $M$ ) is analogous to Capacitor ( $C$ ).
2. Force is analogous to current  $I$ .
3. Displacement ( $x$ ) is analogous to flux ( $\psi$ ).
4. Coefficient of friction ( $B$ ) is analogous to resistance  $1/R$  and
5. Spring constant  $K$  is analogous to inverse of the inductor ( $L$ ).

This analogy is known as force current analogy.

### OUTCOMES:

At the end of the unit, the students are able to:

- Mathematical modeling of mechanical, electrical, servo mechanism and hydraulic systems.
- To find Transfer function of a system.

### SELF-TEST QUESTIONS:

1. What mathematical model permits easy interconnection of physical systems?
2. Define the transfer function.
3. What are the component parts of the mechanical constants of a motor's transfer function?
4. Derive the transfer function of a Spring - Mass-Damper –system.
5. Differentiate between FI and FV analogy.
6. Obtain Transfer function of Armature controlled DC motor.
7. Derive transfer function for the Electrical system shown in Figure below.

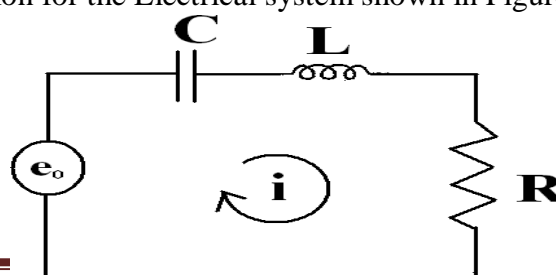



S J P N Trust's

**Hirasugar Institute of Technology, Nidasoshi.**

*Inculcating Values, Promoting Prosperity*

Approved by AICTE, Recognized by Govt. of Karnataka and Affiliated to VTU Belagavi.

**Mechanical**

**Academic**

**Notes**

**Control Engineering-  
15ME73**

**FURTHER READING:**

1. **Modern Control Systems**, Richard.C.Dorf and Robert.H.Bishop, Addison Wesley, 1999
2. **System dynamics & control**, Eronini-Umez, Thomson Asia pte Ltd. singapore, 2002.
3. **Feedback Control System**, Schaum's series. 2001.



S J P N Trust's

**Hirasugar Institute of Technology, Nidasoshi.**

*Inculcating Values, Promoting Prosperity*

Approved by AICTE, Recognized by Govt. of Karnataka and Affiliated to VTU Belagavi.

**Mechanical**

**Academic**

**Notes**

**Control Engineering-  
15ME73**

## **BLOCK DIAGRAMS AND SIGNAL FLOW GRAPHS**

### **LESSON STRUCTURE:**

**Transfer Functions definition**

**Block Diagram:**

**Signal Flow Graphs**

**Mason's Gain Formula**

### **OBJECTIVES:**

- To teach students the concepts of block diagrams and transfer functions.
- To teach students the concepts of Signal flow graph.

### **Transfer Functions definition**

The transfer function of a control system is defined as the ration of the Laplace transform of the output variable to Laplace transform of the input variable assuming all initial conditions to be zero.

$$G(s) = \frac{C(s)}{R(s)} \Rightarrow R(s).G(s) = C(s)$$

function, block representation of systems elements, reduction of block diagrams, Signal flow graphs:  
Mason's gain formula.

### **Block Diagram:**

A control system may consist of a number of components. In order to show the functions performed by each component in control engineering, we commonly use a diagram called the **Block Diagram**.

A block diagram of a system is a pictorial representation of the function performed by each component and of the flow of signals. Such a diagram depicts the inter-relationships which exists between the various components. A block diagram has the advantage of indicating more realistically the signal flows of the actual system.

In a block diagram all system variables are linked to each other through functional blocks. The —Functional Block or simply —Block is a symbol for the mathematical operation on the input signal to the block which produces the output. The transfer functions of the components are usually entered in the corresponding blocks, which are connected by arrows to indicate the direction of flow of signals. Note that signal can pass only in the direction of arrows. Thus a block diagram of a control system explicitly shows a unilateral property.

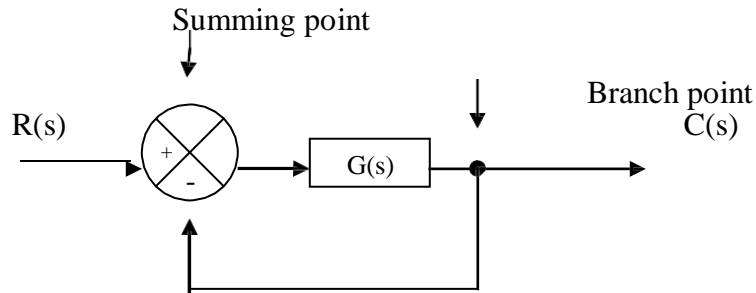
**Block diagram of a closed loop system.**

The output  $C(s)$  is fed back to the summing point, where it is compared with reference input  $R(s)$ . The closed loop nature is indicated in fig 1.3. Any linear system may be represented by a block diagram consisting of blocks, summing points and branch points. A branch is the point from which the output signal from a block diagram goes concurrently to other blocks or summing points.

When the output is fed back to the summing point for comparison with the input, it is necessary to convert the form of output signal to that of the input signal. This conversion is followed by the feedback element whose transfer function is  $H(s)$  as shown in fig 1.4. Another important role of the feedback element is to modify the output before it is compared with the input.

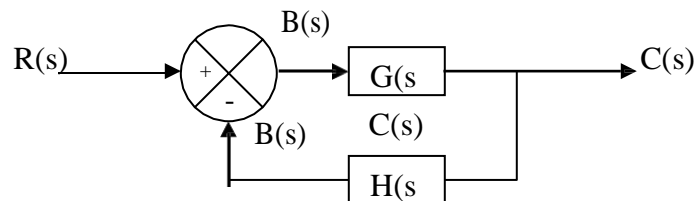





The ratio of the feed back signal  $B(s)$  to the actuating error signal  $E(s)$  is called the open loop transfer function.

$$\text{open loop transfer function} = B(s)/E(s) = G(s)H(s)$$

The ratio of the output  $C(s)$  to the actuating error signal  $E(s)$  is called the feed forward transfer function .

$$\text{Feed forward transfer function} = C(s)/E(s) = G(s)$$

If the feed back transfer function is unity, then the open loop and feed forward transfer function are the same. For the system shown in Fig1.4, the output  $C(s)$  and input  $R(s)$  are related as follows.

$$C(s) = G(s) E(s)$$

$$E(s) = R(s) - B(s)$$

$$= R(s) - H(s) C(s) \quad \text{but } B(s) = H(s)C(s)$$

Eliminating  $E(s)$  from these equations

$$C(s) = G(s) [R(s) - H(s) C(s)]$$

$$C(s) + G(s) [H(s) C(s)] = G(s) R(s)$$

$$C(s)[1 + G(s)H(s)] = G(s)R(s)$$

$$\frac{C(s)}{R(s)} = \frac{G(s)}{1 + G(s) H(s)}$$

$C(s)/R(s)$  is called the closed loop transfer function.

The output of the closed loop system clearly depends on both the closed loop transfer function and the nature of the input. If the feed back signal is positive, then

$$\frac{C(s)}{R(s)} = \frac{G(s)}{1 - G(s) H(s)}$$

## SIGNAL FLOW GRAPHS

An alternate to block diagram is the signal flow graph due to S. J. Mason. A signal flow



S J P N Trust's

**Hirasugar Institute of Technology, Nidasoshi.**

*Inculcating Values, Promoting Prosperity*

Approved by AICTE, Recognized by Govt. of Karnataka and Affiliated to VTU Belagavi.

**Mechanical**

**Academic**

**Notes**

**Control Engineering-  
15ME73**

graph is a diagram that represents a set of simultaneous linear algebraic equations. Each signal flow graph consists of a network in which nodes are connected by directed branches. Each node

	S J P N Trust's	<b>Mechanical</b>
	<b>Hirasugar Institute of Technology, Nidasoshi.</b>	<b>Academic</b>
	<i>Inculcating Values, Promoting Prosperity</i>	<b>Notes</b>
	Approved by AICTE, Recognized by Govt. of Karnataka and Affiliated to VTU Belagavi.	<b>Control Engineering- 15ME73</b>

represents a system variable, and each branch acts as a signal multiplier. The signal flows in the direction indicated by the arrow.

### Definitions:

**Node:** A node is a point representing a variable or signal.

**Branch:** A branch is a directed line segment joining two nodes.

**Transmittance:** It is the gain between two nodes.

**Input node:** A node that has only outgoing branch(es). It is also, called as source and corresponds to independent variable.

**Output node:** A node that has only incoming branches. This is also called as sink and corresponds to dependent variable.

**Mixed node:** A node that has incoming and out going branches.

**Path:** A path is a traversal of connected branches in the direction of branch arrow.

**Loop:** A loop is a closed path.

**Self loop:** It is a feedback loop consisting of single branch.

**Loop gain:** The loop gain is the product of branch transmittances of the loop.

**Non-touching loops:** Loops that do not possess a common node.

**Forward path:** A path from source to sink without traversing an node more than once.

**Feedback path:** A path which originates and terminates at the same node.

**Forward path gain:** Product of branch transmittances of a forward path.

### Properties of Signal Flow Graphs:

1. Signal flow applies only to linear systems.
2. The equations based on which a signal flow graph is drawn must be algebraic equations in the form of effects as a function of causes. Nodes are used to represent variables. Normally the nodes are arranged left to right, following a succession of causes and effects through the system.
3. Signals travel along the branches only in the direction described by the arrows of the branches.
4. The branch directing from node  $X_k$  to  $X_j$  represents dependence of the variable  $X_j$  on  $X_k$  but not the reverse.
5. The signal traveling along the branch  $X_k$  and  $X_j$  is multiplied by branch gain  $a_{kj}$  and signal  $a_{kj}X_k$  is delivered at node  $X_j$ .

### Guidelines to Construct the Signal Flow Graphs:

The signal flow graph of a system is constructed from its describing equations, or by

	S J P N Trust's	<b>Hirasugar Institute of Technology, Nidasoshi.</b>
	<i>Inculcating Values, Promoting Prosperity</i>	
	Approved by AICTE, Recognized by Govt. of Karnataka and Affiliated to VTU Belagavi.	
	<b>Mechanical</b>	
		<b>Academic</b>
		<b>Notes</b>
		<b>Control Engineering- 15ME73</b>

direct reference to block diagram of the system. Each variable of the block diagram becomes a node and each block becomes a branch. The general procedure is

1. Arrange the input to output nodes from left to right.



2. Connect the nodes by appropriate branches.
3. If the desired output node has outgoing branches, add a dummy node and a unity gain branch.
4. Rearrange the nodes and/or loops in the graph to achieve pictorial clarity.

### Mason's Gain Formula:

The relationship between an input variable and an output variable of a signal flow graph is given by the net gain between input and output nodes and is known as overall gain of the system. Mason's gain formula is used to obtain the overall gain (transfer function) of signal flow graphs.

Gain  $P$  is given by

$$P = \frac{1}{\Delta} \sum_k P_k \Delta_k$$

Where,  $P_k$  is gain of  $k^{\text{th}}$  forward path,  
 $\Delta$  is determinant of graph

$\Delta = 1 - (\text{sum of all individual loop gains}) + (\text{sum of gain products of all possible combinations of two nontouching loops}) - (\text{sum of gain products of all possible combination of three nontouching loops}) + \dots$

$\Delta_k$  is cofactor of  $k^{\text{th}}$  forward path determinant of graph with loops touching  $k^{\text{th}}$  forward path. It is obtained from  $\Delta$  by removing the loops touching the path  $P_k$ .

### Example 1

Obtain the transfer function of  $C/R$  of the system whose signal flow graph is shown in Figure

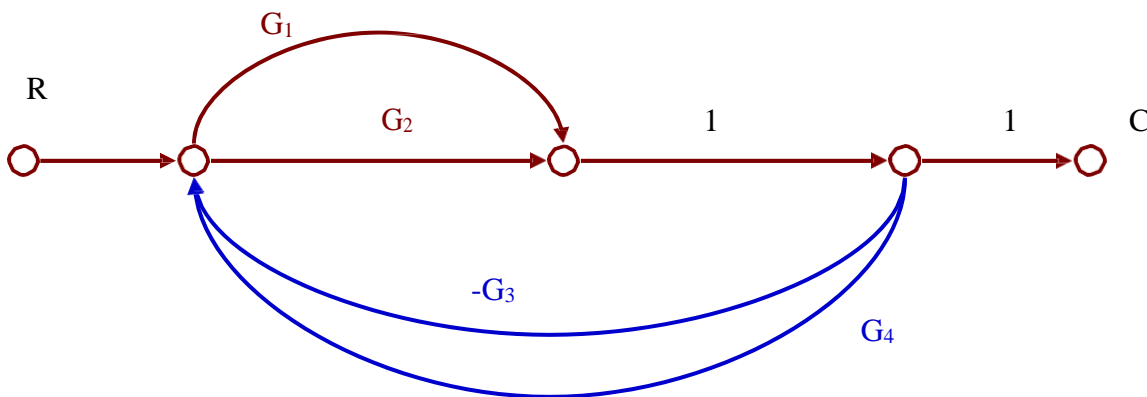



S J P N Trust's

**Hirasugar Institute of Technology, Nidasoshi.**

*Inculcating Values, Promoting Prosperity*

Approved by AICTE, Recognized by Govt. of Karnataka and Affiliated to VTU Belagavi.

**Mechanical**

**Academic**

**Notes**

**Control Engineering-  
15ME73**

There are two forward  
paths: Gain of path 1 :



S J P N Trust's

Hirasugar Institute of Technology, Nidasoshi.

Inculcating Values, Promoting Prosperity

Approved by AICTE, Recognized by Govt. of Karnataka and Affiliated to VTU Belagavi.

Mechanical

Academic

Notes

Control Engineering-  
15ME73

$$P_1 = G_1$$

$$\text{Gain of path 2 : } P_2 = G_2$$

There are four loops with loop gains:

$$L_1 = -G_1G_3, L_2 = G_1G_4, L_3 = -G_2G_3, L_4 = G_2G_4$$

There are no non-touching loops.

$$\Delta = 1 + G_1G_3 - G_1G_4 + G_2G_3 - G_2G_4$$

Forward paths 1 and 2 touch all the loops. Therefore,  $\Delta_1 = 1, \Delta_2 = 1$

$$\text{The transfer function } T = \frac{C(s)}{R(s)} = \frac{P_1\Delta_1 + P_2\Delta_2}{\Delta} = \frac{G_1 + G_2}{1 + G_1G_3 - G_1G_4 + G_2G_3 - G_2G_4}$$

### Example 2

Obtain the transfer function of  $C(s)/R(s)$  of the system whose signal flow graph is shown in Figure

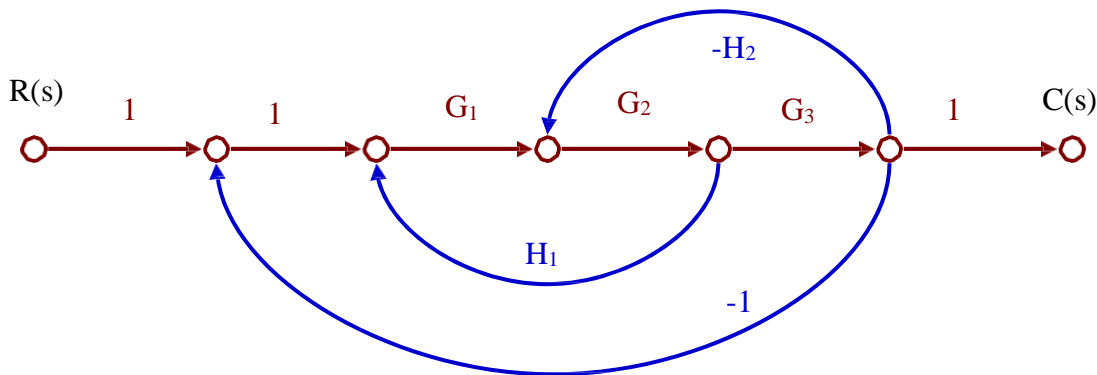

There is one forward path, whose gain is:  $P_1 = G_1G_2G_3$

There are three loops with loop gains:

$$L_1 = -G_1G_2H_1, L_2 = G_2G_3H_2, L_3 = -G_1G_2G_3$$

There are no non-touching loops.

$$\Delta = 1 - G_1G_2H_1 + G_2G_3H_2 + G_1G_2G_3$$

Forward path 1 touches all the loops. Therefore,  $\Delta_1 = 1$ .

$$\text{The transfer function } T = \frac{C(s)}{R(s)} = \frac{P_1\Delta_1}{\Delta} = \frac{G_1G_2G_3}{1 - G_1G_2H_1 + G_2G_3H_2 + G_1G_2G_3}$$

**OUTCOMES:**

At the end of the unit, the students are able to:

1. Represent the systems consisting of number of components in the form of block diagrams and signal flow graphs.
2. Develop mathematical models using reduction technique of these block diagrams and signal flow graphs.

**SELF-TEST QUESTIONS:**

1. Differentiate between Block diagram and Signal flow graph techniques.
2. Explain the rules for constructing Signal flow graph.
3. Reduce the block diagram shown in Figure 1, to its simplest possible form and find its closed loop transfer function.

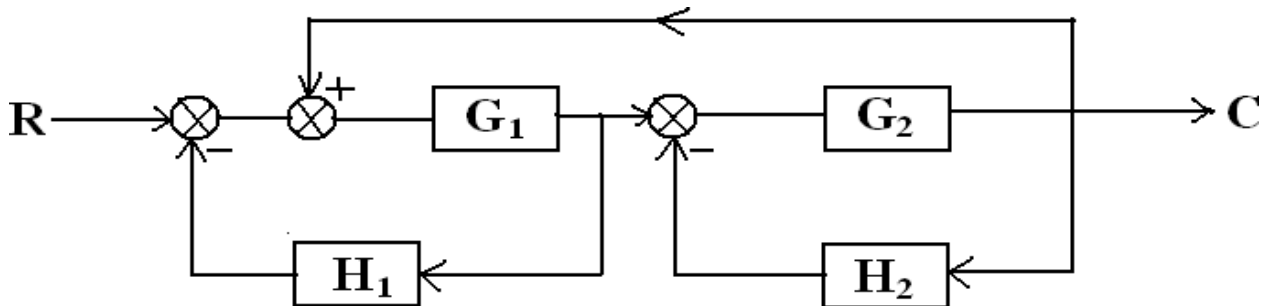

Figure 1

4. Find  $C(S)/R(S)$  for the following system using Mason's gain rule shown in figure 2.

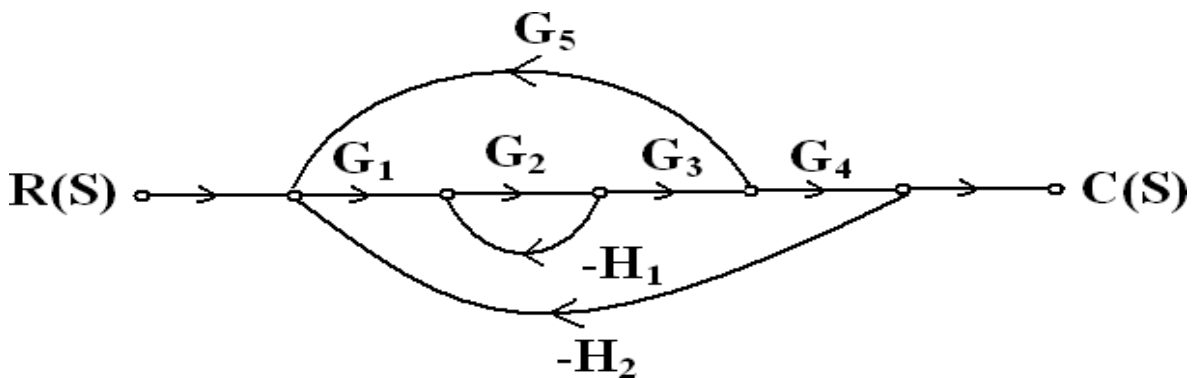

Figure 2

**FURTHER READING:**

1. **Modern Control Systems**, Richard.C.Dorf and Robert.H.Bishop, Addison Wesley, 1999
2. **System dynamics & control**, Eronini-Umez, Thomson Asia pte Ltd. singapore, 2002.
3. **Feedback Control System**, Schaum's series. 2001.





S J P N Trust's

**Hirasugar Institute of Technology, Nidasoshi.**

*Inculcating Values, Promoting Prosperity*

Approved by AICTE, Recognized by Govt. of Karnataka and Affiliated to VTU Belagavi.

**Mechanical**

**Academic**

**Notes**

**Control Engineering-  
15ME73**

**Module-3****TRANSIENT AND STEADY STATE RESPONSE ANALYSIS****LESSON STRUCTURE:****Introduction****Time Response****Steady State Response****Routh's-Hurwitz Criterion****OBJECTIVES:**

- To demonstrate the time response and steady-state error of the system.
- To educate static and transient behavior of a system.
- To demonstrate stability of the various control systems by applying Routh's stability criterion.

**Introduction:**

Time is used as an independent variable in most of the control systems. It is important to analyse the response given by the system for the applied excitation, which is function of time. Analysis of response means to see the variation of output with respect to time. The output behavior with respect to time should be within these specified limits to have satisfactory performance of the systems. The stability analysis lies in the time response analysis that is when the system is stable output is finite

The system stability, system accuracy and complete evaluation is based on the time response analysis on corresponding results.

**Time Response:**

The response given by the system which is function of the time, to the applied excitation is called time response of a control system.

Practically, output of the system takes some finite time to reach to its final value. This time varies from system to system and is dependent on different factors. The factors like friction mass or inertia of moving elements some nonlinearities present etc. Example: Measuring instruments like Voltmeter, Ammeter.

**Classification:**

The time response of a control system is divided into two parts.

1 Transient response  $c_t(t)$

2 Steady state response  $c_{ss}(t)$

$$\therefore c(t) = c_t(t) + c_{ss}(t)$$

Where  $c(t)$  = Time Response

Total Response = Zero State Response + Zero Input Response.



S J P N Trust's

**Hirasugar Institute of Technology, Nidasoshi.**

*Inculcating Values, Promoting Prosperity*

Approved by AICTE, Recognized by Govt. of Karnataka and Affiliated to VTU Belagavi.

**Mechanical**

**Academic**

**Notes**

**Control Engineering-  
15ME73**

### **Steady State Response:**

It is defined the part of the response which remains after complete transient response



vanishes from the system output.

$$\text{i.e., } \lim_{t \rightarrow \infty} c_t(t) = c_{ss}(t)$$

The time domain analysis essentially involves the evaluation of the transient and Steady state response of the control system.

For the analysis point of view, the signals, which are most commonly used as reference inputs, are defined as **standard test inputs**.

- The performance of a system can be evaluated with respect to these test signals.
- Based on the information obtained the design of control system is carried out. The
- commonly used test signals are
  1. Step Input signals.
  2. Ramp Input Signals.
  3. Parabolic Input Signals.
  4. Impulse input signal.

### 1. Step input signal (position function)

It is the sudden application of the input at a specified time as usual in the figure or instant any us change in the reference input

Example :-

- a. If the input is an angular position of a mechanical shaft a step input represent the sudden rotation of a shaft.
- b. Switching on a constant voltage in an electrical circuit.
- c. Sudden opening or closing a valve.

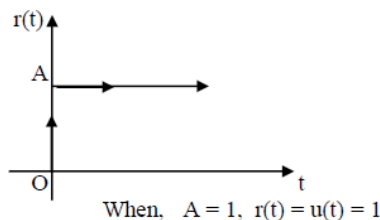

The step is a signal who's value changes from 1 value (usually 0) to another level A in Zero time.

In the Laplace Transform form  $R(s) = A / S$

Mathematically  $r(t) = u(t)$

$$= 1 \text{ for } t \geq 0$$

$$= 0 \text{ for } t < 0$$

### 2. Ramp Input Signal (Velocity Functions):

It is constant rate of change in input that is gradual application of input as shown in fig (2 b).

$r(t)$

Ex:- Altitude Control of a Missile

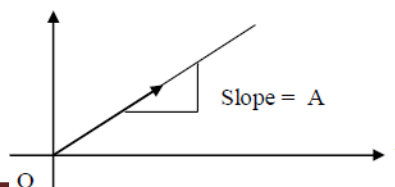



S J P N Trust's

**Hirasugar Institute of Technology, Nidasoshi.**

*Inculcating Values, Promoting Prosperity*

Approved by AICTE, Recognized by Govt. of Karnataka and Affiliated to VTU Belagavi.

**Mechanical**

**Academic**

**Notes**

**Control Engineering-  
15ME73**

The ramp is a signal, which starts at a value of zero and increases linearly with time.  
Mathematically  $r(t) = At$  for  $t \geq 0$



$$= 0 \text{ for } t \leq 0.$$

In LT form  $R(S) = \frac{A}{S^2}$

$$S^2$$

If  $A=1$ , it is called Unit Ramp Input

### Parabolic Input Signal (Acceleration function):

- The input which is one degree faster than a ramp type of input as shown in fig (2 c) or it is an integral of a ramp .
- Mathematically a parabolic signal of magnitude

$$A \text{ is given by } r(t) = \frac{A t^2}{2} u(t)$$

$$r(t) = \begin{cases} \frac{A t^2}{2} & \text{for } t \geq 0 \\ 0 & \text{for } t \leq 0 \end{cases}$$

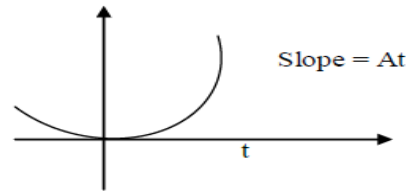

$$\text{In LT form } R(S) = \frac{A}{S^3}$$

- If  $A = 1$ , a unit parabolic function is defined as  $r(t) = \frac{t^2}{2} u(t)$

$$\text{ie., } r(t) \quad \left\{ \begin{array}{l} \frac{t^2}{2} \text{ for } t \geq 0 \\ 0 \text{ for } t \leq 0 \end{array} \right.$$

$$\text{In LT for } R(S) = \frac{1}{S^3} = \frac{t^2}{2} \text{ for } t \geq 0$$

$$0 \text{ for } t \leq 0$$

### Impulse Input Signal :

It is the input applied instantaneously (for short duration of time ) of very high amplitude as shown in fig 2(d)

Eg: Sudden shocks i e, HV due lightening or short circuit.

It is the pulse whose magnitude is infinite while its width tends to zero.

ie.,  $t \rightarrow 0$  (zero) applied momentarily

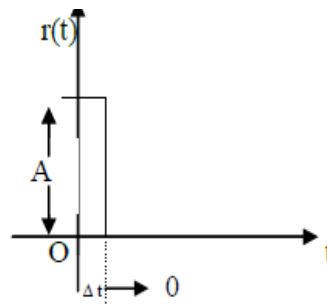

Area of impulse = Its magnitude

If area is unity, it is called **Unit Impulse Input** denoted as  $\delta(t)$

Mathematically it can be expressed as

$$r(t) = A \text{ for } t = 0$$

$$= 0 \text{ for } t \neq 0$$

In LT form  $R(S) = 1$  if  $A = 1$

### Routh's-Hurwitz Criterion

E.J. Routh (1877) developed a method for determining whether or not an equation has roots with + ve real parts without actually solving for the roots.



S J P N Trust's

# Hirasugar Institute of Technology, Nidasoshi.

*Inculcating Values, Promoting Prosperity*

Approved by AICTE, Recognized by Govt. of Karnataka and Affiliated to VTU Belagavi.

**Mechanical**

**Academic**

**Notes**

**Control Engineering-  
15ME73**

A necessary condition for the system to be **STABLE** is that the real parts of the roots of the characteristic equation have - ve real parts. This insures that the impulse response will decay



exponentially with time.

If the system has some roots with real parts equal to zero, but none with +ve real parts the system is said to be **MARGINALLY STABLE**.

It determines the poles of a characteristic equation with respect to the left and the right half of the S-plane without solving the equation.

The roots of this characteristic equation represent the closed loop poles. The stability of the system depends on these poles. The necessary, but not sufficient conditions for the system having no roots in the right half S-Plane are listed below.

- i. All the co-efficients of the polynomial must have the same sign.
- ii. All powers of S, must present in descending order.
- iii. The above conditions are not sufficient.

In a vast majority of practical systems. The following statements on stability are quite useful.

- i. If all the roots of the characteristic equation have -ve real parts the system is **STABLE**.
- ii. If any root of the characteristic equation has a +ve real part or if there is a repeated root on the j -axis, the system is **unstable**.
- iii. If condition (i) is satisfied except for the presence of one or more non repeated roots on the j -axis the system is limitedly **STABLE**

In this instance the impulse response does not decay to zero although it is bounded. Additionally certain inputs will produce outputs. Therefore **marginally stable** systems are **UNSTABLE**.

The Routh Stability criterion is a method for determining system stability that can be applied to an nth order characteristic equation of the form

$$s^n + a_{n-1} s^{n-1} + a_{n-2} s^{n-2} + a_{n-3} s^{n-3} + \dots + a_1 s^1 + a_0 = 0$$

The criterion is applied through the use of a Routh Array (Routh table) Defined as follows:

$s^n$	$a_n$	$a_{n-2}$	$a_{n-4}$
$s^{n-1}$	$a_{n-1}$	$a_{n-3}$	$a_{n-5}$
$s^{n-2}$	$b_1$	$b_2$	$b_3$
$s^{n-3}$	$c_1$	$c_2$	$c_3$
$s^{n-4}$	$d_1$	$d_2$	
.			
.			
$s^2$	$e_1$	$a_0$	
$s^1$	$f_1$		
$s^0$	$a_0$		

**The ROUTH STABILITY CRITERION is stated as follows,**

All the terms in the first column of Routh's Array should have same sign, and there should





S J P N Trust's

# Hirasugar Institute of Technology, Nidasoshi.

*Inculcating Values, Promoting Prosperity*

Approved by AICTE, Recognized by Govt. of Karnataka and Affiliated to VTU Belagavi.

**Mechanical**

**Academic**

**Notes**

**Control Engineering-  
15ME73**

not be any change of sign.

This is a necessary and sufficient condition for the system to be stable. On the other hand any change



of sign in the first column of Routh's Array indicates,

- The System is Unstable, and
- The Number of changes of sign gives the number of roots lying in the right half of S-Plane

Example : find the stability of the system using Routh's criteria. For the equation  
 $3S^4+10S^3+5S^2+5S+2=0$

S4	3	5	2
S3	10	5	0
S3	(2)	(1)	0
S2	7/2	2	0
S1	-1/7	0	
S0	2		

Here two roots are +ve (2 changes of sign) and hence the system is **unstable**.

### OUTCOMES:

At the end of the unit, the students are able to:

- Obtain the time response and steady-state error of the system.
- Knowledge about improvement of static and transient behavior of a system.
- Determine stability of the various control systems by applying Routh's stability criterion.

### SELF-TEST QUESTIONS:

- Obtain an expression for time response of the first order system subject to step input.
- Define
  - Time response.
  - Transient response.
  - Steady state response.
  - Steady state error.
- Determine the stability of the system whose characteristic equation is given by  $S^4+6S^3+23S^2+40S+50=0$ , Using Routh's criterion.

### FURTHER READING:

- Modern Control Systems**, Richard.C.Dorf and Robert.H.Bishop, Addison Wesley, 1999
- System dynamics & control**, Eronini-Umez, Thomson Asia pte Ltd. singapore, 2002.
- Feedback Control System**, Schaum's series. 2001.



## Module-4

### Frequency Response Analysis

#### LESSON STRUCTURE

##### Nyquist Stability criterion

##### Nyquist criterion using Nyquist plots

##### Simplified forms of the Nyquist criterion

##### The Nyquist criterion using Bode plots

#### OBJECTIVES:

- To demonstrate Stability Determine Gain & Phase Margins Medium effort.
- To demonstrate applications of the frequency response to analysis of system stability (the Nyquist criterion), relating the frequency response to transient performance specifications.
- Finds number of RHP poles of  $T(s)$ , the closed-loop transfer function.

#### Nyquist Stability criterion

This graphical method, which was originally developed for the stability analysis of feedback amplifiers, is especially suitable for different control applications. With this method the closed-loop stability analysis is based on the locus of the open-loop frequency response

$G_o(j\omega)$ . Since only knowledge of the frequency response  $G_o(j\omega)$  is necessary, it is a versatile practical approach for the following cases:

- For many cases  $G_o(j\omega)$  can be determined by series connection of elements whose parameters are known.
- Frequency responses of the loop elements determined by experiments or  $G_o(j\omega)$  can be considered directly.
- Systems with dead time can be investigated.
- Using the frequency response characteristic of  $G_o(j\omega)$  not only the stability analysis, but also the design of stable control systems can be easily performed.

#### Nyquist criterion using Nyquist plots

To derive this criterion one starts with the rational transfer function of the *open loop*

$$G_o(s) = \frac{N_o(s)}{D_o(s)}$$

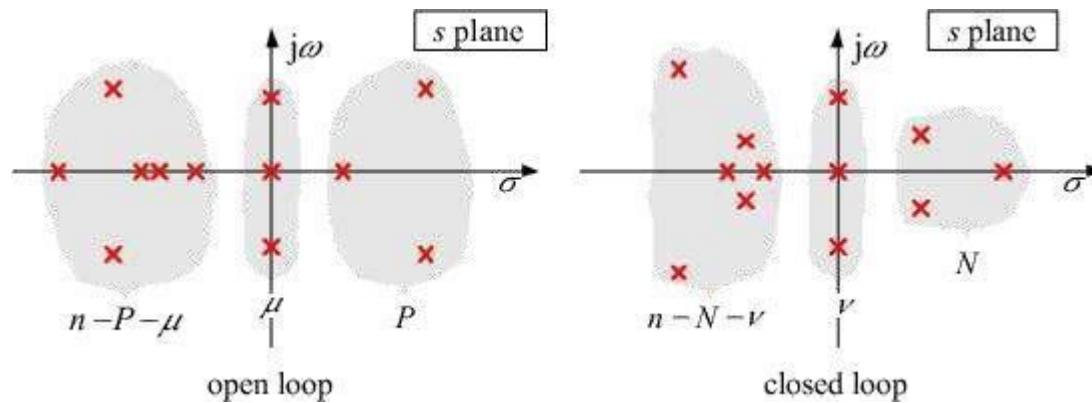

Figure: Poles of the open and closed loop in the s plane (multiple poles are counted according to their multiplicity)

To determine  $\Delta\varphi_s$ , the locus  $G'(j\omega) = 1 + G_0(j\omega)$  can be drawn on the Nyquist diagram and the phase angle checked. Expediently one moves this curve by 1 to the left in the  $G_0(j\omega)$  plane. Thus for stability analysis of the closed loop the locus  $G_0(j\omega)$  of the open loop according to Figure 5.5 has to be drawn.

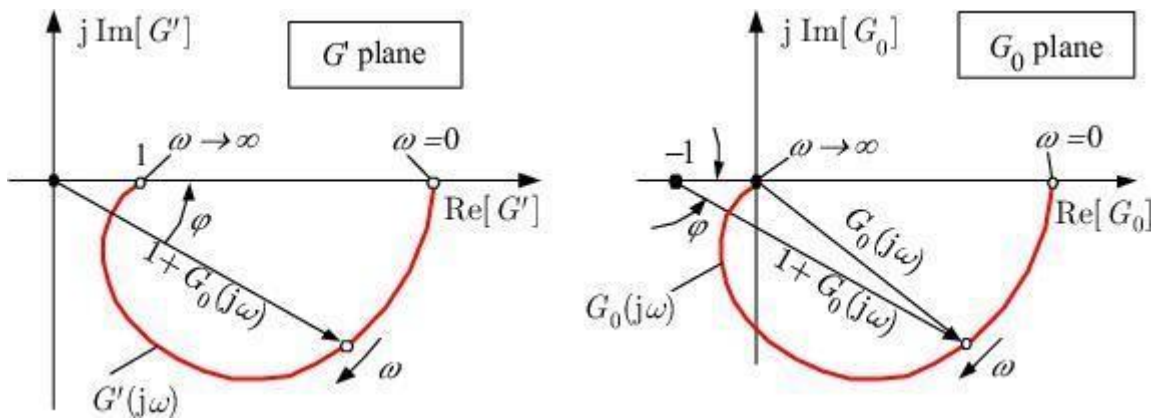

Figure : Nyquist diagrams of  $G'(j\omega)$  and  $G_0(j\omega)$

Here  $\Delta\varphi_s$  is the continuous change in the angle of the vector from the so called *critical point*  $(-1, j0)$  to the moving point on the locus of  $G_0(j\omega)$  for  $0 \leq \omega \leq \infty$ . Points where the locus passes through the point  $(-1, j0)$  or where it has points at infinity correspond to the zeros and poles of  $G'(s)$  on the imaginary axis, respectively. These discontinuities are not taken into account for the derivation of  $G_0(j\omega)$ . Figure shows an example of  $G_0(j\omega)$ .

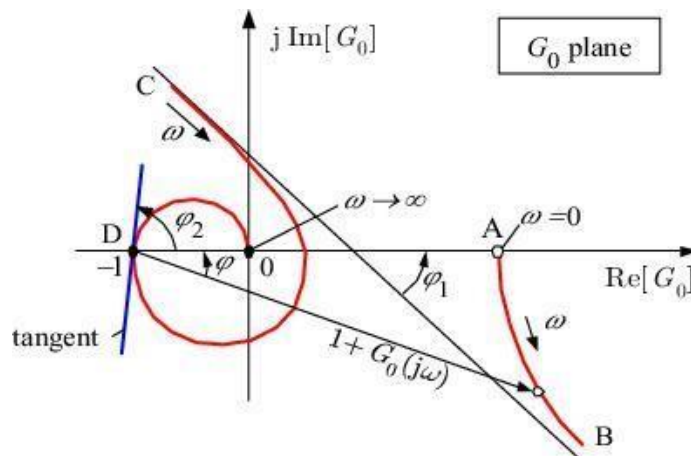

Figure: Determination of continuous changes in the angle  $\Delta\varphi_S$

where two discontinuous changes of the angle occur. Thereby the continuous change of the angle consists of three parts

$$\begin{aligned} \Delta\varphi_S &= \Delta\varphi_{AB} + \Delta\varphi_{CD} + \Delta\varphi_{DO} \\ &= -\varphi_1 - (2\pi - \varphi_1 - \varphi_2) - \varphi_2 = -2\pi \end{aligned}$$

The rotation is counter clockwise positive.

As the closed loop is only asymptotically stable for  $N = \nu = 0$ , then from the *general case of the Nyquist criterion* follows:

The closed loop is asymptotically stable, if and only if the continuous change in the angle of the vector from the critical point  $(-1, j0)$  to the moving point of the locus  $G_0(j\omega)$  of the open loop is

$$\Delta\varphi_S = (P + \mu/2)\pi$$

For the case with a *negative* gain  $K_0$  of the open loop the locus is rotated by  $180^\circ$  relative to the case with a *positive*  $K_0$ . The Nyquist criterion remains valid also in the case of a *dead time* in the open loop.

### Simplified forms of the Nyquist criterion

It follows from that for an open-loop stable system, that is  $P = 0$  and  $\mu = 0$ , then  $\Delta\varphi_S = 0$ . Therefore the Nyquist criterion can be reformulated as follows:



If the open loop is asymptotically stable, then the closed loop is only asymptotically stable, if the frequency response locus of the open loop does neither revolve around or pass through the critical point  $(-1, j0)$ .

Another form of the simplified Nyquist criterion for  $G_0(s)$  with poles at  $s = -\sigma$  is the so called 'left-hand rule':

The open loop has only poles in the left-half plane with the exception of a single or double pole at  $(s = 0)$  or behaviour. In this case the closed loop is only stable, if the critical point  $(-1, j0)$  is on the *left* hand-side of the locus  $G_0(j\omega)$  in the direction of increasing values of  $\omega$ .

This form of the Nyquist criterion is sufficient for most cases. The part of the locus that is significant is that closest to the critical point. For very complicated curves one should go back to the general case. The left-hand rule can be graphically derived from the generalised locus

The orthogonal  $(\sigma, \omega)$ -net is observed and asymptotic stability of the closed loop is given, if a curve with  $\sigma < 0$  passes through the critical point  $(-1, j0)$ . Such a curve is always on the left-hand side of  $G_0(j\omega)$ .

### The Nyquist criterion using Bode plots

Because of the simplicity of the graphical construction of the frequency response characteristics of a given transfer function the application of the Nyquist criterion is often more simple using Bode plots. The continuous change of the angle  $\Delta\varphi_s$  of the vector from the critical point  $(-1, j0)$  to the locus of  $G_0(j\omega)$  must be expressed by the amplitude and phase response of  $G_0(j\omega)$ . From figure

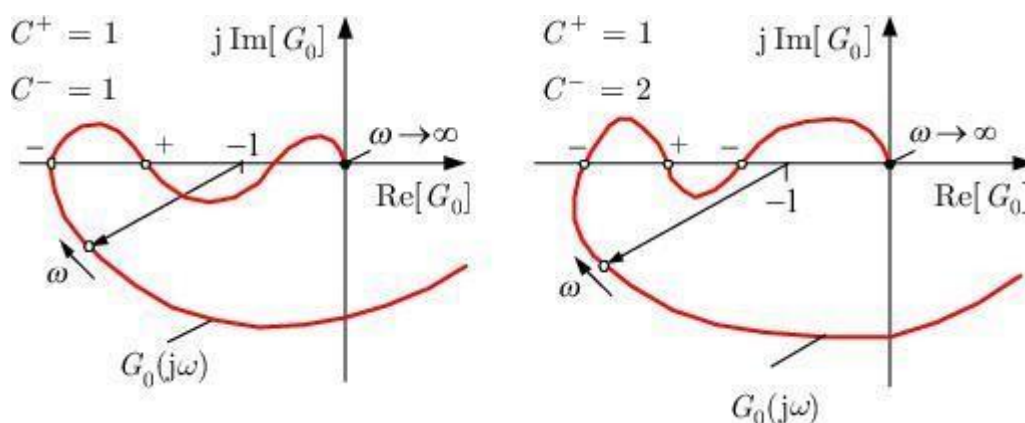

**Figure :** Positive (+) and negative (-) intersections of the locus  $G_0(j\omega)$  with the real axis on the left-hand side of the critical point

it can be seen that this change of the angle is directly related to the count of intersections of  
 Department of Mechanical Engineering, HIT, Nidasoshi



the locus with the real axis on the left-hand side of the critical point between  $(-\infty, -1)$ . The Nyquist criterion can therefore also be represented by the count of these intersections if the gain of the open loop is positive.

Regarding the intersections of the locus of  $G_0(j\omega)$  with the real axis in the range  $(-\infty, -1)$ , the transfer from the upper to the lower half plane in the direction of increasing  $\omega$  values are treated as *positive intersections* while the reverse transfer are *negative intersections* (Figure 5.7). The change of the angle is zero if the count of positive intersections  $S^+$  is equal

to the count of negative intersections  $S^-$ . The change of the angle depends also on the number of positive and negative intersections and if the open loop does not have poles on the imaginary axis, the change of the angle is

$$\Delta\varphi_S = 2\pi(C^+ - C^-)$$

In the case of an open loop containing an integrator, i.e. a single pole in the origin of the complex plane ( $\mu = 1$ ), the locus starts for  $\omega = 0$  at  $\delta - j\infty$ , where an additional  $+\pi/2$  is added to the change of the angle. For proportional and integral behaviour of the open loop

$$\Delta\varphi_S = 2\pi(C^+ - C^-) + \mu\pi/2 \quad \mu = 0, 1$$

is valid. In principle this relation is also valid for  $\mu = 2$ , but the locus starts for  $\omega = 0$  at  $-\infty + j\delta$  (Figure 5.8), and this intersection would be counted

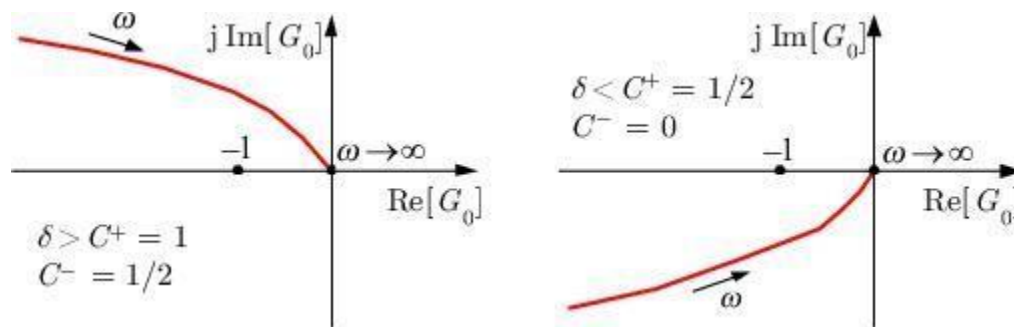

**Figure :** Count of the intersections on the left-hand side of the critical point for  $I_2$  behaviour of the open loop

as a negative one if  $\delta > 0$ , i.e. if the locus for small  $\omega$  is in the upper half plane of the real axis. But

de facto there is for  $\delta > 0$  (and accordingly  $\delta < 0$ ) no intersection. This follows from the detailed investigation of the discontinuous change of the angle, which occurs at  $\omega = 0$ . As only a continuous change of the angle is taken into account and because of reason of symmetry the start of the locus

at  $\omega = 0$  is counted as a half intersection, positive for  $\delta < 0$  and negative for  $\delta > 0$ , which is analogous to the definition given above For continuous changes of the angle

$$\Delta\varphi_S = 2\pi(C^+ - C^-) \quad (\mu = 2)$$



S J P N Trust's

# Hirasugar Institute of Technology, Nidasoshi.

*Inculcating Values, Promoting Prosperity*

Approved by AICTE, Recognized by Govt. of Karnataka and Affiliated to VTU Belagavi.

**Mechanical**

**Academic**

**Notes**

**Control Engineering-  
15ME73**

The open loop with the transfer function  $G_0(s)$  has  $P$  poles in the left-half plane and possibly a





single ( $\mu = 1$ ) or double pole ( $\mu = 2$ ) at  $s = 0$ . If the locus of  $G_0(j\omega)$  has  $C^+$  positive and  $C^-$  negative intersections with the real axis to the left of the critical point, then the closed loop is only asymptotically stable, if

$$D^* = C^+ - C^- = \begin{cases} \frac{P}{2} & \text{for } \mu = 0, 1 \\ \frac{P+1}{2} & \text{for } \mu = 2 \end{cases}$$

is valid. For the special case, that the open loop is stable ( $P = 0$ ), the number of positive and negative intersections must be equal.

From this it follows that the difference of the number of positive and negative intersections in the case of  $\mu = 0, 1$  is an integer and for  $\mu = 2$  not an integer. From this follows immediately, that for  $\mu = 0, 1$  the number  $P$  is even, for  $\mu = 2$  the number  $P + 1$  is uneven and therefore in all cases  $P$  is an even number, such that the closed loop is asymptotically stable. This is only valid if  $D^* \geq 1$ .

The Nyquist criterion can now be transferred directly into the representation using frequency response characteristics. The magnitude response  $A_0(\omega)_{dB}$ , which corresponds to the locus  $G_0(j\omega)$ , is always positive at the intersections of the locus with the real axis in the range of  $(-\infty, -1)$ . These points of intersection correspond to the crossings of the phase response  $\varphi_0(\omega)$  with lines  $\pm 180^\circ, \pm 540^\circ$  etc., i.e. a uneven multiple of  $^\circ$ . In the case of a positive intersection of the locus, the phase response at the  $\pm(2k + 1) 180^\circ$  lines crosses from below to top and reverse from top to below on a negative intersection as shown in Figure 5.9. In the following these crossings

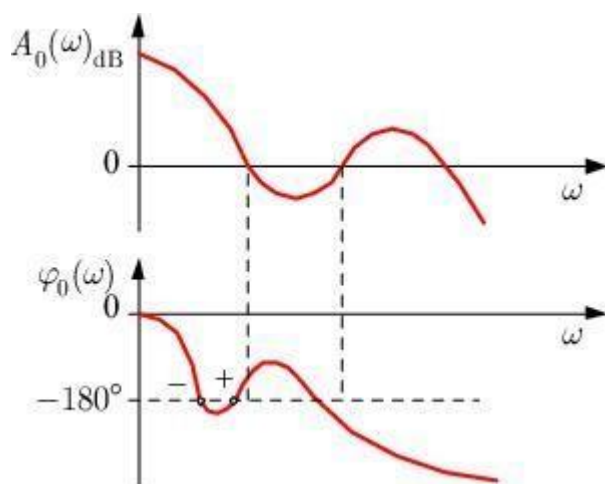

Figure : Frequency response characteristics of  $G_0(j\omega) = A_0(\omega) e^{j\varphi_0(\omega)}$  and definition of positive (+) and negative (-) crossings of the phase response  $\varphi_0(\omega)$  with the  $^\circ$  line



will be defined as positive (+) and negative (-) crossings of the phase response  $\varphi_0(\omega)$  over the particular  $\pm(2k + 1) 180^\circ$  lines, where  $k = 0, 1, 2, \dots$  may be valid. If the phase response starts at  $-180^\circ$  this point is counted as a half crossing with the corresponding sign. Based on the discussions above the Nyquist criterion can be formulated in a form suitable for frequency response characteristics:

The open loop with the transfer function  $G_0(s)$  has  $P$  poles in the right-half plane, and possibly a single or double pole at  $s = 0$ .  $C^+$  are the number of positive and  $C^-$  of negative crossings of the phase response  $\varphi_0(\omega)$  over the  $\pm(2k + 1) 180^\circ$  lines in the frequency range where  $A_0(\omega)_{dB} > 0$  is valid. The closed loop is only asymptotically stable, if

$$D^* = C^+ - C^- = \begin{cases} \frac{P}{2} & \text{for } \mu = 0, 1 \\ \frac{P+1}{2} & \text{for } \mu = 2 \end{cases}$$

is valid. For the special case of an open-loop stable system  $P = 0, \mu = 0$

$$D^* = C^+ - C^- = 0$$

must be valid.

**Table 7.1:** Examples of stability analysis using the Nyquist criterion with frequency response characteristics

No.	Bode Diagram	Stability Analysis
1		$\Rightarrow \left. \begin{matrix} S^+ = 1 \\ S^- = 2 \\ D^* = -1 \\ P = 2 \end{matrix} \right\} \Rightarrow D^* \neq P/2: \text{unstable}$
2		$\Rightarrow \left. \begin{matrix} S^+ = 3/2 \\ S^- = 1 \\ D^* = 1/2 \\ P = 0 \end{matrix} \right\} \Rightarrow D^* = \frac{P+1}{2}: \text{stable if } 2 \text{ poles in the origin}$
3		$\Rightarrow \left. \begin{matrix} S^+ = 0 \\ S^- = 1 \\ D^* = -1 \\ P = 0 \end{matrix} \right\} \Rightarrow D^* \neq P/2: \text{unstable}$
4		$\Rightarrow \left. \begin{matrix} S^+ = 0 \\ S^- = 0 \\ D^* = 0 \\ P = 0 \end{matrix} \right\} \Rightarrow D^* = P/2: \text{stable}$



Finally the 'left-hand rule' will be given using Bode diagrams, because this version is for the most cases sufficient and simple to apply.

The open loop has only poles in the left-half  $s$  plane with the exception of possibly one single or one multiple pole at  $s = 0$  (P, I or behaviour). In this case the closed loop is only asymptotically stable, if  $G_0(j\omega)$  has a phase of  $\varphi_0 > -180^\circ$  for the crossover frequency  $\omega_C$  at  $A_0(\omega_C)_{dB} = 0$ .

This stability criterion offers the possibility of a practical assessment of the 'quality of stability' of a control loop. The larger the distance of the locus from the critical point the farther is the closed loop from the stability margin. As a measure of this distance the terms gain margin and phase margin are introduced according to Figure below

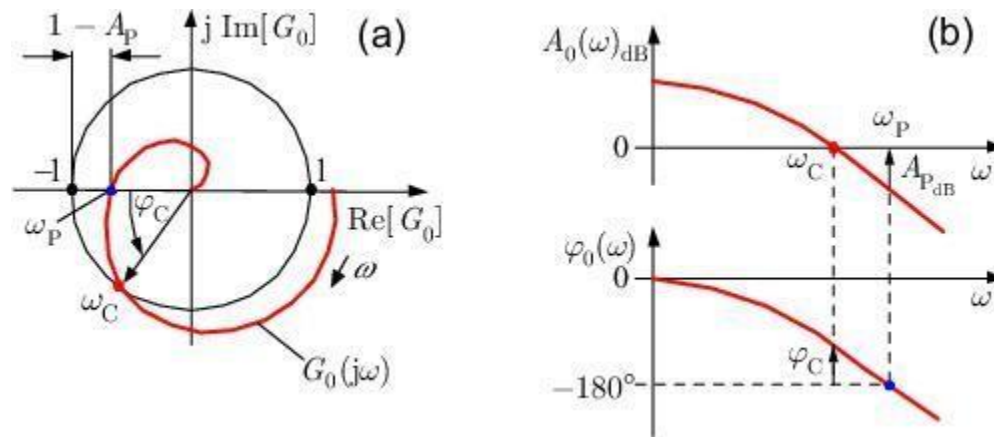

**Figure:** Phase and gain margin  $\varphi_C$  and  $A_P$  or  $A_{P_{dB}}$ , respectively, in the (a) Nyquist diagram and (b) Bode diagram

**Example Problems:**

**Q1** The polar plot of the open-loop transfer of feedback control system intersects the real axis at  $-2$ . Calculate gain margin (in dB) of the system.

**Ans.** Given  $a = -2$

$$\text{Gain margin} = 20 \log_{10} \left| \frac{1}{a} \right|$$

$$= 20 \log_{10} |0.5|$$

gain margin =  $-6.02$  dB.



**Q2. What is the gain margin of a system in decibels if its Nyquist plot cuts the negative real axis at  $-0.7$ ?**

Ans.

$$a = -0.7$$

$$\begin{aligned} \text{gain margin} &= -20 \log_{10} \left| \frac{1}{a} \right| \\ &= -20 \log_{10} \left| \frac{1}{0.7} \right| \\ \text{gain margin} &= -3 \text{ dB.} \end{aligned}$$

**Q4. Consider a feed back system with the open-loop transfer function. Given by**

$$G(s) = \frac{K}{s(2s+1)}$$

**Examine the stability of the closed-loop system. Using Nyquist stability theory**

Ans.  $G(s)H(s) = \frac{K}{s(2s+1)}$

Here poles are  $s = 0, -\frac{1}{2}$ . One pole is at origin and one is at  $-\frac{1}{2}$ . But no pole is at right half of s-plane.

$$\therefore P = 0$$

For stability,

$$N = Z - P$$

$$Z = P + N$$

$N \Rightarrow$  Number of clockwise encirclement about  $(-1 + j0)$

As there is no encirclement, so  $N = 0$

$$Z = 0 + 0$$

$$= 0$$

Thus system is stable.

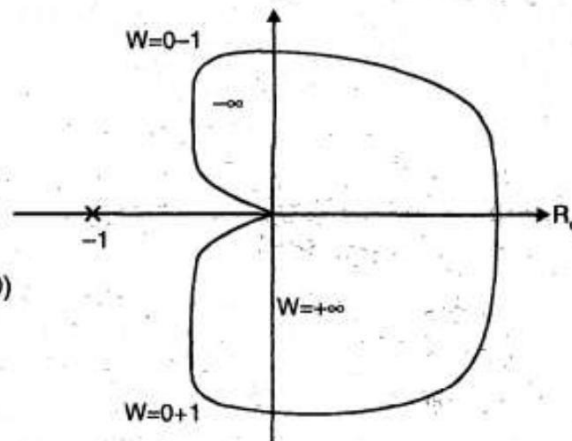



Q 5. Draw the Nyquist plot for the open loop transfer function given below:

$$G(s)H(s) = \frac{1}{s(1+2s)(1+s)}$$

and obtain the gain margin and phase margin

Ans. Given  $G(s)H(s) = \frac{1}{s(1+2s)(1+s)}$

Put  $s = j\omega$

$$G(j\omega)H(j\omega) = \frac{1}{j\omega(1+2j\omega)(1+j\omega)}$$

Rationalizing

$$G(j\omega)H(j\omega) = \frac{-3}{(1+4\omega^2)(1+\omega^2)} - j \frac{1-2\omega^2}{\omega(1+4\omega^2)(1+\omega^2)}$$

Equating imaginary parts to zero, real axis intersection is at

$$1 - 2\omega^2 = 0$$

$$\omega = 0.707$$

$$|G(j\omega)H(j\omega)|_{\omega=0.707} = 0.66$$

Nyquist plot is as shown :

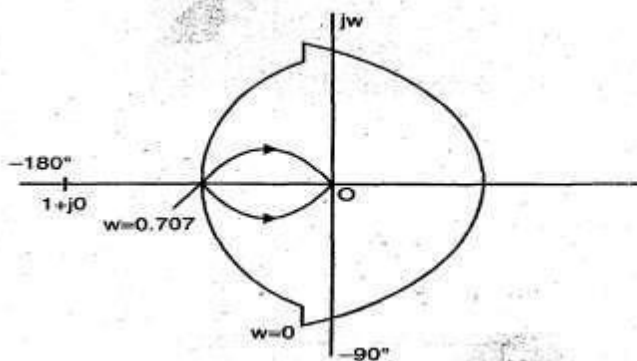



Q6. Consider a feed back system with the open-loop transfer function. Given by

$$G(s) = \frac{K}{s(2s+1)}$$

Examine the stability of the closed-loop system. Using Nyquist stability theory.

Ans.  $G(s)H(s) = \frac{K}{s(2s+1)}$

Here poles are  $s = 0, -\frac{1}{2}$ . One pole is at origin and one is at  $-\frac{1}{2}$ . But no pole is at right half of s-plane.

$$\therefore P = 0$$

For stability,

$$N = Z - P$$

$$Z = P + N$$

$N \Rightarrow$  Number of clockwise enrichment about  $(-1 + j0)$

As there is no enrichment, so  $N = 0$

$$Z = 0 + 0$$

$$= 0$$

Thus system is stable.

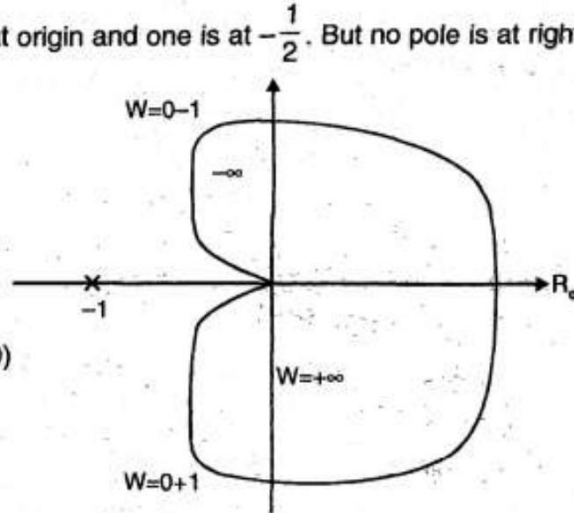

Q7. Sketch the Nyquist plot for the system with the open loop transfer function

$$\frac{K}{(j\omega + 1)(j\omega + 1.5)(j\omega + 2)}$$

and determine the range of K for which the system is

Ans. Given  $G(s)H(s) = \frac{K}{(s+1)(s+1.5)(s+2)}$

Put  $s = j\omega$

$$G(j\omega)H(j\omega) = \frac{K}{(s+1)(s+1.5)(s+2)}$$



Rationalizing and separating real and imaginary parts

$$= \frac{(3 - 4.5\omega^2)K}{(1 + \omega^2)(2.25 + \omega^2)(4 + \omega^2)} - \frac{JK(6.5\omega - \omega^3)}{(1 + \omega^2)(2.25 + \omega^2)(4 + \omega^2)}$$

To get point of intersection on real axis, equate imaginary part to zero.

$$\Rightarrow \frac{K(6.5\omega - \omega^3)}{(1 + \omega^2)(2.25 + \omega^2)(4 + \omega^2)} = 0$$

$$\omega = 2.55 \text{ rad/sec}$$

$$|G(j\omega)|_{\omega=2.25} = -0.24K$$

Intersection with imaginary axis :

$$\omega = \sqrt{\frac{3}{4.5}} = 0.81$$

$$|G(j\omega)H(j\omega)|_{\omega=2.25} = -0.028K$$

For stability  $-0.028K < -1$

$$K < 35.03.$$

The plot is as shown below :

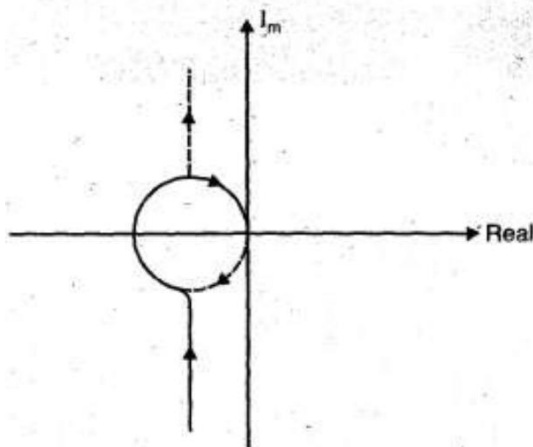

Sketch the Nyquist plot for system with

$$G(s)H(s) = \frac{(1 + 0.5s)}{s^2(1 + 0.1s)(1 + 0.02s)}$$

Comment on the stability.



$$\text{Ans. } G(s) H(s) = \frac{(1+0.5s)}{s^2(1+0.1s)(1+0.02s)}$$

$$\text{Put } s = j\omega$$

$$G(j\omega) H(j\omega) = \frac{(1+0.5j\omega)}{(j\omega)^2(1+0.1j\omega)(1+0.02j\omega)}$$

The mapping for Nyquist contour is as follow.

Along  $j\omega$  axis for various values of  $\omega$ ,  $G(j\omega) H(j\omega)$  is plotted.

$$\omega \quad 0 \quad \infty \quad 0.1 \quad 1.0 \quad 2.0 \quad 4.0 \quad 10.0 \quad 20.00$$

$$\text{where } |G(j\omega) H(j\omega)| = \frac{\sqrt{1+0.25\omega^2}}{\omega^2 \sqrt{1+0.01\omega^2} \sqrt{1+0.0004\omega^2}}$$

$$\angle G(j\omega) H(j\omega) = \tan^{-1} 0.5\omega - 180^\circ - \tan^{-1} 0.1\omega - \tan^{-1} 0.02\omega$$

Point of intersection of  $G(j\omega) H(j\omega)$

$$\angle G(j\omega) H(j\omega) = -180^\circ + \tan^{-1} 0.5\omega - 180^\circ - \tan^{-1} 0.1\omega - \tan^{-1} 0.02\omega = 180^\circ$$

$$\tan^{-1} 0.5\omega = \tan^{-1} 0.1\omega + \tan^{-1} 0.02\omega$$

$$0.5\omega = \frac{(0.1)(\omega + 0.02\omega)}{1 - 0.002\omega^2}$$

$$(1 - 0.002\omega^2)(0.5\omega) = 0.1\omega + 0.02\omega$$

$$0.5\omega - 0.001\omega^3 = 0.12\omega$$

$$0.38 = 0.001\omega^2$$

$$\omega = 19.49 \text{ rad/sec}$$

$$\begin{aligned} |G(j\omega) H(j\omega)|_{\omega=19.49} &= \frac{1 + j0.25 \times 19.49}{(j19.49)^2 (1 + j0.1 \times 19.49) (1 + j0.002 \times 19.49)} \\ &= \frac{1 + 4.8725j}{(19.49j)^2 (1 + 1.949j) (1 + 0.0389j)} \end{aligned}$$





The plot is as shown below :

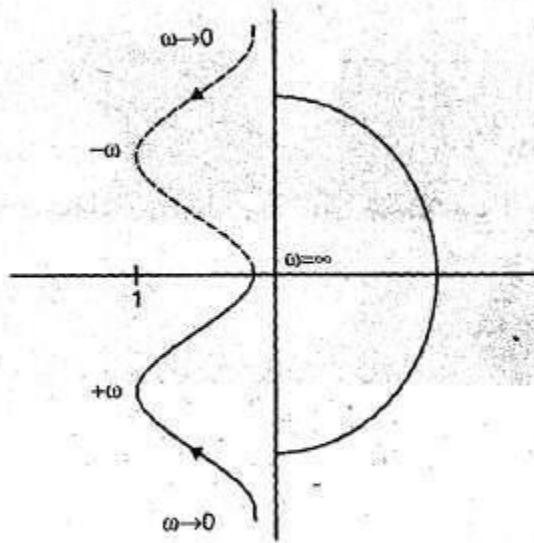

There is no encirclement of  $1 + j0$ , hence system is stable.

**Q 9. How is it possible to make assessment of relative stability using Nyquist criterion? Construct Nyquist plot for the system whose open loop transfer function is**

$$G(s) H(s) = \frac{K(1+s)^2}{s^3}$$

**Find the range of K for stability.**

Ans.

- Nyquist criterion can be used to make assessment of relative
- Using the characteristic equation the Nyquist plot is drawn. A feedback system is stable if and only if, the i.e. contour in the  $G(s)$  plane does not encircle the  $(-1, 0)$  point when the number of poles of  $G(s)$  in the right hand  $s$  plane is
- If  $G(s)$  has  $P$  poles in the right hand plane, then the number of anticlockwise encirclements of the  $(-1, 0)$  point must be equal to  $P$  for a stable system,  $N = -P$

where  $N$  = No of clockwise encirclements about  $(-1, 0)$  point in  $C(s)$  plane  
 $P$  = No of poles  $G(s)$  in RHP

Now given  $G(s) H(s) = \frac{K(1+s)^2}{s^3}$

No. of poles at RHS of  $s$ -plane  $P = 0$

For stability  $N = 0$

Nyquist path is shown :

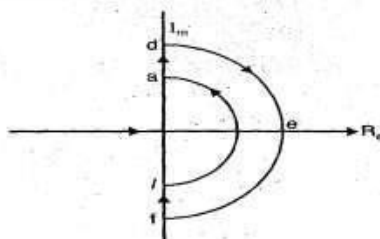

For path  $a - d$ , put  $s = j\omega$ ,  $0 < \omega < \infty$

$\omega = 0$ ,  $G(j\omega) H(j\omega) = \infty \angle -270^\circ$

$\omega = \infty$ ,  $G(j\omega) H(j\omega) = 0 \angle -90^\circ$



S J P N Trust's

**Hirasugar Institute of Technology, Nidasoshi.**

*Inculcating Values, Promoting Prosperity*

Approved by AICTE, Recognized by Govt. of Karnataka and Affiliated to VTU Belagavi.

**Mechanical**

**Academic**

**Notes**

**Control Engineering-  
15ME73**

## **OUTCOMES:**

At the end of the unit, the students are able to:

- To Determine Gain & Phase Margins Medium effort.
- Applications of the frequency response to analysis of system stability (the Nyquist criterion), relating the frequency response to transient performance specifications.
- To find number of RHP poles of  $T(s)$ , the closed-loop transfer function.

## **SELF-TEST QUESTIONS:**

1. Apply Nyquist stability criterion for the system with transfer function

$$G(S)H(S) = \frac{K}{S(S+2)(S+4)}$$
 find the stability.

## **FURTHER READING:**

1. **Modern Control Systems**, Richard.C.Dorf and Robert.H.Bishop, Addison Wesley, 1999
2. **System dynamics & control**, Eronini-Umez, Thomson Asia pte Ltd. singapore, 2002.
3. **Feedback Control System**, Schaum's series. 2001.



## Module-4

### FREQUENCY RESPONSE ANALYSIS USING BODE PLOTS

#### LESSON STRUCTURE

#### Bode attenuation diagrams

#### Stability analysis using Bode plots

#### OBJECTIVES:

- To demonstrate frequency response and to determine stability of control system applying using Bode plot.
- To demonstrate to plot graph of amplitude plot, usually in the log-log scale and a phase plot, which is usually a linear-log plot.

#### Bode attenuation diagrams

If the absolute value  $A(\omega)$  and the phase  $\varphi(\omega)$  of the frequency response  $G(j\omega) = A(\omega) e^{j\varphi(\omega)}$

are separately plotted over the frequency  $\omega$ , one obtains the

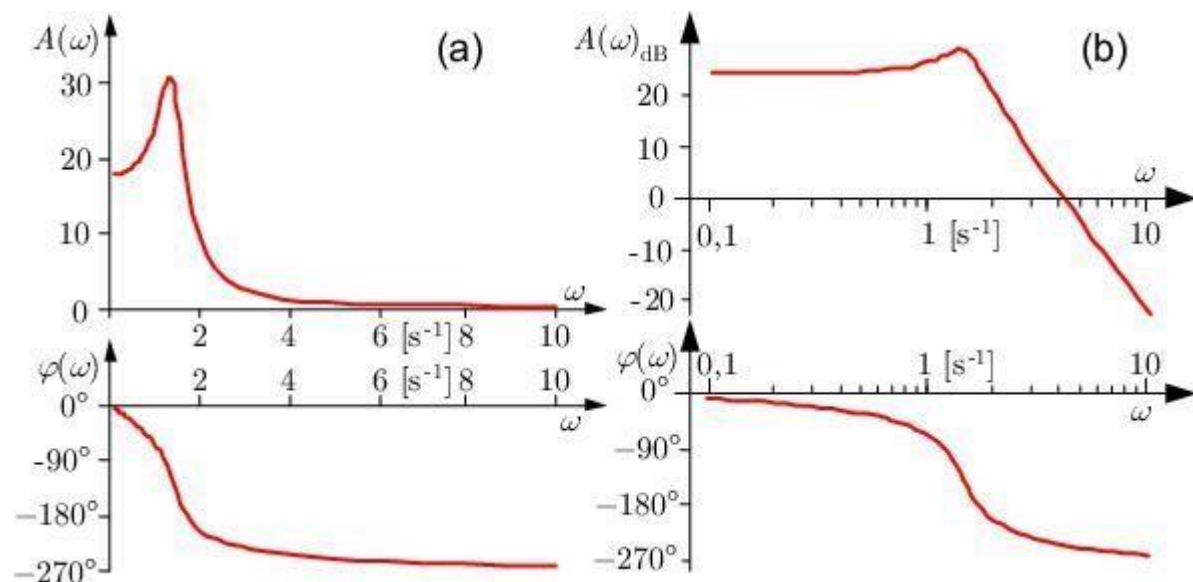

**Figure 6.1:** Plot of a frequency response: (a) linear, (b) logarithmic presentation ( $\omega$  on a logarithmic scale) (Bode plot)

*amplitude response* and the *phase response*. Both together are the *frequency response*

*characteristics*.  $A(\omega)$  and  $\omega$  are normally drawn with a logarithm and  $\varphi(\omega)$  with a linear scale.

This representation is called a *Bode diagram* or *Bode plot*. Usually  $A(\omega)$  will be specified in decibels [dB] By definition this is

$$A(\omega)_{\text{dB}} = 20 \log_{10} A(\omega) \quad [\text{dB}]$$



S J P N Trust's

**Hirasugar Institute of Technology, Nidasoshi.**

*Inculcating Values, Promoting Prosperity*

Approved by AICTE, Recognized by Govt. of Karnataka and Affiliated to VTU Belagavi.

**Mechanical**

**Academic**

**Notes**

**Control Engineering-  
15ME73**

The logarithmic representation of the amplitude response  $A(\omega)_{dB}$  has consequently a linear scale in this diagram and is called the *magnitude*.



## Stability analysis using Bode plots:

- The magnitude and phase relationship between sinusoidal input and steady state output of a system is known as frequency
- The polar plot of a sinusoidal transfer function  $G(j\omega)$  is plot of the magnitude of  $G(j\omega)$  versus the phase angle of  $G(j\omega)$  on polar coordinates as  $\omega$  varied from zero to infinity.
- The phase margin is that amount, of additional phase lag at the gain crossover frequency required to bring the system to the verge of
- The gain margin is the reciprocal of the magnitude  $|G(j\omega)|$  at the frequency at which the phase angle as
- The inverse polar plot at  $G(j\omega)$  is a graph of  $1/G(j\omega)$  as a function of
- Bode plot is a graphical representation of the transfer function for determining the stability of control
- Bode plot is a combination of two plot - magnitude plot and phase
- The transfer function having no poles and zeros in the right -half s-plane are called minimum phase transfer
- System with minimum phase transfer function are called minimum phase systems.
- The transfer function having poles and zeros in the right half s-plane are called non-minimum phase transfer functions systems with non-minimum phase transfer function. are called non-minimum phase
- In bode plot the relative stability of the system is determined from the gain margin and phase margin. .
- If gain cross frequency is less than phase cross over frequency then gain margin and phase margin both are positive and system is
- If gain cross over frequency is greater than the phase crossover frequency than both gain margin and 'phase margin are
- If gain cross over frequency is equal to the phase cross over frequency the gain margin and phase margin are zero and system is marginally
- The maximum value of magnitude is known as resonant
- The magnitude of resonant peak gives the information about the relative stability of the
- The frequency at which magnitude has maximum value is known as resonant frequency.
- Bandwidth is defined as the range of frequencies in which the magnitude of closed loop does not drop  $-3$  db.

**Example Problems:**

Q1. Sketch the Bode Plot for the transfer function given by,

$$G(s) H(s) = \frac{2(s+0.25)}{s^2(s+1)(s+0.5)}$$

and from Plot find (a) Phase and Gain cross over frequencies (b) Gain Margin and Phase Margin. Is this System Stable?

Ans. Given  $G(s) H(s) = \frac{2(s+0.25)}{s^2(s+1)(s+0.5)}$

$$= \frac{2 \times 0.25}{0.5} \left[ \frac{s}{0.25} + 1 \right]$$
$$= \frac{1}{s^2(s+1)} \left[ \frac{s}{0.5} + 1 \right]$$

$$= \frac{1(4s+1)}{s^2(s+1)(2s+1)}$$

Put  $s = j\omega$

$$G(j\omega) H(j\omega) = \frac{(j4\omega+1)}{(j\omega^2)(j\omega+1)(2j\omega+1)}$$



This is type 2 system, hence initial slope of bode plot =  $-40$  dB/decade and the plot intersects  $0$  dB axis at  $\omega = \sqrt{K} = \sqrt{1} = 1$  rad/sec. The corner frequencies are :

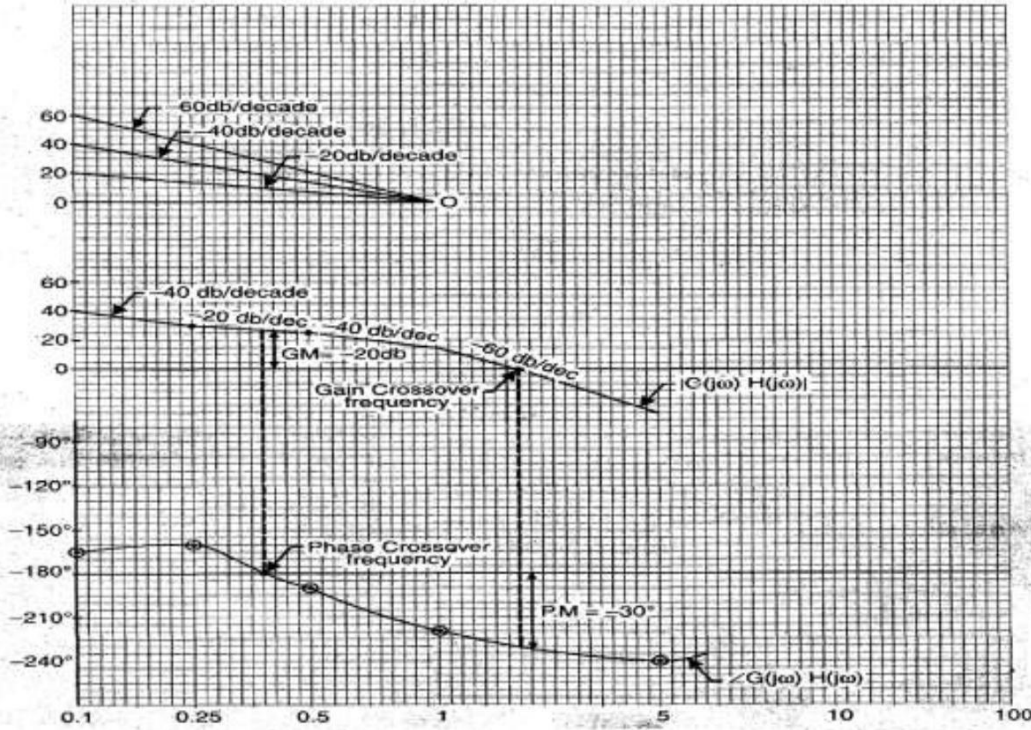

$$\omega = \frac{1}{4} = 0.25 \text{ rad/sec}$$

$$\omega = \frac{1}{2} = 0.5 \text{ rad/sec}$$

$$\omega = 1 \text{ rad/sec.}$$

Frequency range is considered from  $\omega = 0.1$  rad/sec to  $\omega = 10$  rad/sec.

The plot is as shown.

As initial slope of plot is  $-40$  dB/dec and corner frequency is  $0.25$  rad/sec. The plot after  $\omega = 0.25$  has slope =  $-20$  dB/dec.

After  $\omega = 0.5$ , slope is  $-40$  dB/decade

After  $\omega = 1$ , slope is  $-60$  dB/dec.

**Phase Angle :**

$$\angle G(j\omega) H(j\omega) = \tan^{-1}(4\omega) - 180^\circ - \tan^{-1}\omega - \tan^{-1}2\omega.$$

The phase angle for frequency range considered are calculated as :

$\omega$	0.1	0.25	0.5	1	5
$\angle G(j\omega) H(j\omega)$	-175.2	-175.2	-188	-212.4	-225



The gain crosses 0db axis at  $\omega_c = 1.24$  rad/sec, the gain crossover frequency is  $\omega_c =$  rad/sec.

The phase crosses  $-180^\circ$  line at  $\omega_c = 0.4$  rad/sec, therefore phase crossover frequency is  $\omega_c = 0.4$  rad/sec.

At phase cross over the gain is 20 dB, therefore gain margin is  $-20$  dB.

At gain crossover the phase angle is  $-215^\circ$ , the phase margin is  $180^\circ + (-215^\circ) = -35^\circ$ .

As both gain and phase margins are negative, the system is unstable.

**Q3. Sketch the bode plot for the transfer function given by**

$$G(s) = \frac{23.7(1+j\omega)(1+0.2j\omega)}{(j\omega)(1+3j\omega)(1+0.5j\omega)(1+0.1j\omega)}$$

**and from plot find gain margin and phase margin.**

**Ans.**

On 0)-axis mark the point at 23.7 rad/sec. since in denominator (j $\omega$ ) term is having power one, from 23.7 draw a line of slope  $-20$  db/decade to meet y-axis. This will be the starting point.

**Step 1.**

From the starting point to I corner frequency (0.33) the slope of the line is  $-20$  db/decade.

From I corner frequency (0.33) to second corner frequency (1) the slope of the line will be  $-20 \div (-20) = -40$  db/decade.

From II corner frequency to IV corner frequency (2) the slope of the line be  $-40 + (\div 20) = -20$  db/decade.

From III corner frequency to IV corner frequency, the slope of line will be  $-20 + (-20) = -40$  db/decade.

From IV corner frequency (5) to V corner frequency the slope will be  $-40 \div (+20) = -20$  db/decade.

After V corner frequency, the slope will be  $(-20) \div (-20) = -40$  db/decade.

**Step 2.**

Draw the phase plot.

**Step 3.**

From graph

Phase margin =  $+34^\circ$

Gain margin = infinity





$$G(j\omega) H(j\omega) = \frac{k}{j\omega (j0.1\omega + 1) (j0.05\omega + 1)}$$

Ans. Advantages of Bode Plot :

Please refer to Q. No. 1 (i) of May 2009.

$$\text{As } G(j\omega) H(j\omega) = \frac{k}{j\omega (j0.1\omega + 1) (j0.05\omega + 1)}$$

Come frequencies are

$$\omega_1 = \frac{1}{0.1} = 10 \text{ rad/sec}$$

$$\omega_2 = \frac{1}{0.05} = 20 \text{ rad/sec}$$

Draw magnitude plot without K.

For phase plot

$\omega$	Arg $j\omega$ $\phi_1$	Arg $(1 + j0.1\omega)$ $\phi_2$	Arg $(1 + j0.05\omega)$ $\phi_3$	Resultant $\phi_1 + \phi_2 + \phi_3$
4	-90°	-21.8°	-11.3°	-123.1°
6	-90°	-30.96°	-16.69°	-137.65°
8	-90°	-38.56°	-21.8°	-150.36°
10	-90°	-45°	-26.56°	-161.56°
12	-90°	-50.19°	-30.96°	-171.46°
14	-90°	-54.46°	-35°	-179.48°
16	-90°	-60.9°	-42°	-192.9°
20	-90°	-63.43°	-45°	-198.43°

$\omega$	$-\tan^{-1} j\omega$	$-\tan^{-1} 3\omega$	$-\tan^{-1} 0.5\omega$	$-\tan^{-1} 0.1\omega$	$\tan^{-1} \omega$	$\tan^{-1} 2\omega$	Resultant
0.1	-90°	-16.7°	-2.86°	-0.57°	+5.71°	1.14°	-103°
0.2	-90°	-31°	-5.71°	-1.14°	+11.3°	2.3°	-114.25°
0.5	-90°	-56.3°	-14.03°	-2.86°	+26.56°	5.71°	-130.92°
0.8	-90°	-67.4°	-21.8°	-4.57°	+38.65°	9.09°	-136.03°
1.0	-90°	-71.56°	-26.56°	-5.71°	+45°	11.3°	-137.5°
2.0	-90°	-80.54°	-45°	-11.3°	+63.43°	21.8°	-141.61°
5.0	-90°	-86.18°	-68.19°	-26.56°	+78.7°	45°	-147.23°
8.0	-90°	-87.61°	-76°	-38.65°	+82.87°	58°	-151.39°
10.0	-90°	-88°	-78.7°	-45°	+84.3°	63.4°	-154.0°
20.0	-90°	-89°	-84.3°	-63.43°	+87.13°	76°	-163.6°

**OUTCOMES:**

At the end of the unit, the students are able to:

- Determine stability of control system applying Nyquist stability criterion and using



S J P N Trust's

# Hirasugar Institute of Technology, Nidasoshi.

*Inculcating Values, Promoting Prosperity*

Approved by AICTE, Recognized by Govt. of Karnataka and Affiliated to VTU Belagavi.

**Mechanical**

**Academic**

**Notes**

**Control Engineering-  
15ME73**

Bode plot.

- Plot a graph of amplitude plot, usually in the log-log scale and a phase plot, which is usually a linear-log plot.

**SELF-TEST QUESTIONS:**

1. The open loop transfer function of a system is given by  $G(S)H(S) = \frac{10(S+10)}{S(S+2)(S+5)}$ .

Draw Bode diagram, Find Gain cross over frequency (GCF), Phase cross over frequency (PCF), Gain margin (GM), Phase margin (PM). Find stability of the system.

2. The open loop transfer function of a system is given by

$$G(S)H(S) = \frac{50K}{S(S+10)(S+6)(S+1)}$$

Draw Bode diagram, Find Gain cross over frequency (GCF), Phase cross over frequency (PCF), Gain margin (GM), Phase margin (PM). Find the value of **K** to have GM=10 decibels.

**FURTHER READING:**

1. **Modern Control Systems**, Richard.C.Dorf and Robert.H.Bishop, Addison Wesley, 1999
2. **System dynamics & control**, Eronini-Umez, Thomson Asia pte Ltd. singapore, 2002.
3. **Feedback Control System**, Schaum's series. 2001.



## Module-3

# ROOT-LOCUS TECHNIQUES

## LESSON STRUCTURE

### Definition of root loci

#### Analysis using root locus plots

#### General rules for constructing root loci

### OBJECTIVES:

- To teach the relationship of the poles (and zeros) of a system's transfer function to its response, including classical time-domain transient performance specifications such as overshoot, rise-time, and settling-time.
- To demonstrate the construction of root loci from open loop transfer functions of control systems and Analyze the behaviour of roots with system gain.

### Definition of root loci

The root locus of a feedback system is the graphical representation in the complex  $s$ -plane of the possible locations of its closed-loop poles for varying values of a certain system parameter. The points that are part of the root locus satisfy the angle condition. The value of the parameter for a certain point of the root locus can be obtained using the magnitude condition.

In **root locus technique in control system** we will evaluate the position of the roots, their locus of movement and associated information. These information will be used to comment upon the system performance.

### Analysis using root locus plots.

A designer can determine whether his design for a control system meets the specifications if he knows the desired time response of the controlled variable. By deriving the differential equations for the control system and solving them, an accurate solution of the system's performance can be obtained, but this approach is not feasible for other than simple systems. It is not easy to determine from this solution just what parameters in the system should be changed to improve the response. A designer wishes to be able to predict the performance by an analysis that does not require the actual solution of the differential equations.

The first thing that a designer wants to know about a given system is whether or not it is stable. This can be determined by examining the roots obtained from the characteristic equation

$$1 + G_0(s) = 0$$

(5.1)



of the closed loop. The work involved in determining the roots of this equation can be avoided by applying the Hurwitz or Routh criterion. Determining in this way whether the system is stable or unstable does not satisfy the designer, because it does not indicate the degree of stability of the system, i.e., the amount of overshoot and the settling time of the controlled variable for a step input. Not only must the system be stable, but the overshoot must be maintained within prescribed bounds and transients must die out in a sufficiently short time.

The root-locus method described in this section not only indicates whether a system is stable or unstable but, for a stable system, also shows the degree of stability. The root locus is a plot of the roots of the characteristic equation of the closed loop as a function of the gain. This graphical approach yields a clear indication of the effect of gain adjustment with relatively small effort.

With this method one determines the closed-loop poles in the  $s$ -plane - these are the roots of Eq.(5.1) - by using the known distribution of the poles and zeros of the open-loop transfer

function  $G_o(s)$ . If for instance a parameter is varied, the roots of the characteristic equation will move on certain curves in the  $s$ -plane as shown by the example in Figure 5.1. On these curves lie all

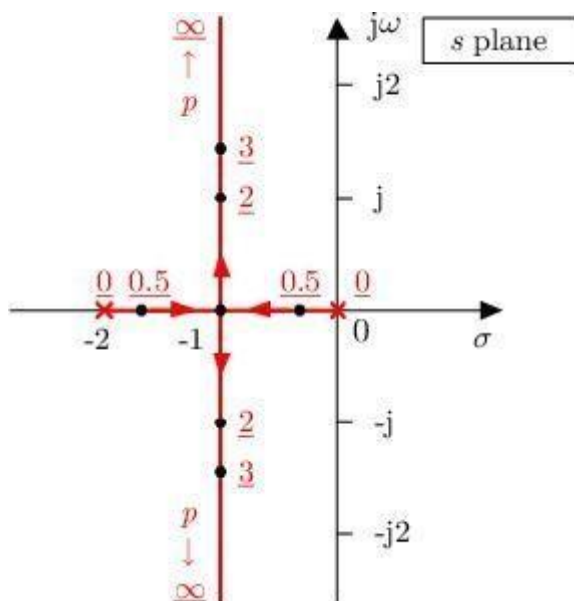

**Figure 5.1:** Plot of all roots of the characteristic equation  $s^2 + 2s + p = 0$  for  $0 \leq p < \infty$ .

Values of  $p$  are red and underlined.

possible roots of the characteristic equation for all values of the varied parameter from zero to infinity. These curves are defined as the *root-locus plot* of the closed loop. Once this plot is obtained, the roots that best fit the system performance specifications can be selected. Corresponding to the selected roots there is a required value of the parameter which can be determined from the plot. When the roots have been selected, the time response can be obtained. Since the process of finding the root locus by calculating the roots for various values of a parameter becomes tedious, a simpler method of obtaining the root locus is desired. The graphical method for determining the root-locus plot is shown in the following.



S J P N Trust's

**Hirasugar Institute of Technology, Nidasoshi.**

*Inculcating Values, Promoting Prosperity*

Approved by AICTE, Recognized by Govt. of Karnataka and Affiliated to VTU Belagavi.

**Mechanical**

**Academic**

**Notes**

**Control Engineering-  
15ME73**

An open-loop transfer function with  $k$  poles at the origin of the  $p$ -plane is often described by



$$G_0(s) = \frac{K_0}{s^k} \frac{1 + \beta_1 s + \dots + \beta_m s^m}{1 + \alpha_1 s + \dots + \alpha_{n-k} s^{n-k}} \quad m \leq n, \quad (5.2)$$

where  $K_0$  is the gain of the open loop. In order to represent this transfer function in terms of the open-loop poles and zeros it is rewritten as

$$G_0(s) = k_0 \frac{\prod_{\mu=1}^m (s - s_{Z_\mu})}{\prod_{\nu=1}^n (s - s_{P_\nu})} = k_0 G(s) \quad (5.3)$$

or

$$G_0(s) = k_0 \frac{\prod_{\mu=1}^m (-s_{Z_\mu})}{\prod_{\nu=1}^{n-k} (-s_{P_\nu})} \frac{1}{s^k} \frac{\prod_{\mu=1}^m \left(1 + \frac{s}{-s_{Z_\mu}}\right)}{\prod_{\nu=1}^{n-k} \left(1 + \frac{s}{-s_{P_\nu}}\right)} \quad (5.4)$$

$s_{P_\nu} \neq 0$

with  $k_0 > 0$  and  $s_{Z_\mu} \neq s_{P_\nu}$ . The relationship between the factor  $k_0$  and the open-loop gain  $K_0$  is

$$K_0 = k_0 \frac{\prod_{\mu=1}^m (-s_{Z_\mu})}{\prod_{\nu=1}^{n-k} (-s_{P_\nu})} \frac{1}{s^k} \quad (5.5)$$

$s_{P_\nu} \neq 0$

The characteristic equation of the closed loop using Eq. (5.3) is

$$1 + k_0 G(s) = 0 \quad (5.6)$$

or

$$G(s) = -\frac{1}{k_0} \quad (5.7)$$

All complex numbers  $s_i = s_i(k_0)$ , which fulfil this condition for  $0 \leq k_0 \leq \infty$ , represent the root locus.



From the above it can be concluded that the magnitude of  $k_0 G(s)$  must always be unity and its phase angle must be an odd multiple of  $\pi$ . Consequently, the following two conditions are formalised for the root locus for all positive values of  $k_0$  from zero to infinity:

a)

*Magnitude condition:*

$$|G(s)| = \frac{1}{k_0} \quad (5.8)$$

b)

*Angle condition*

$$\varphi(s) = \arg G(s) = \pm 180^\circ (2k + 1) \quad \text{for } \begin{matrix} k = 0, 1, 2, \dots \\ k_0 \geq 0 \end{matrix} \quad (5.9)$$

In a similar manner, the conditions for negative values of  $k_0$  ( $-\infty \leq k_0 < 0$ ) can be determined. The magnitude conditions is the same, but the angle must satisfy the

c)

*Angle condition*

$$\varphi(s) = \arg G(s) = \pm k 360^\circ \quad \text{for } \begin{matrix} k = 0, 1, 2, \dots \\ k_0 < 0 \end{matrix} \quad (5.10)$$

Apparently the angle condition is independent of  $k_0$ . All points of the  $s$  plane that fulfil the angle condition are the loci of the poles of the closed loop by varying  $k_0$ . The calibration of the curves by the values of  $k_0$  is obtained by the magnitude condition according to Eq. (5.8). Based upon this interpretation of the conditions the root locus can be constructed in a graphical/numerical way.

Once the open-loop transfer function  $G_0(s)$  has been determined and put into the proper form, the poles and zeros of this function are plotted in the  $s$  plane.

- The plot of the locus of the closed loop poles as a function of the open loop gain  $K$ , when  $K$  is varied from 0 to  $+\infty$
- When system gain  $K$  is varied from 0 to  $+\infty$ , the locus is called direct root
- When system gain  $K$  is varied from  $-\infty$  to 0, the locus is called as inverse root locus.
- The root locus is always symmetrical about the real axis i.e.  $x$ -axis.
- The number of separate branches of the root locus equals either the number of open loop poles or number of open-loop zeros whichever is less
- A section of root locus lies on the real axis if the total number of open-loop poles and zeros to the right of the section is odd
- If the root locus intersects the imaginary axis then the point of intersection are





S J P N Trust's

# Hirasugar Institute of Technology, Nidasoshi.

*Inculcating Values, Promoting Prosperity*

Approved by AICTE, Recognized by Govt. of Karnataka and Affiliated to VTU Belagavi.

**Mechanical**

**Academic**

**Notes**

**Control Engineering-  
15ME73**

conjugate. From the open loop complex pole the root locus departs making an angle with the horizontal line.



- The root locus starts from open-loop
- The root locus terminates either on open loop zero or
- infinity. The number of branches of roots locus

$N$  if  $P > Z$

and  $M$  if  $P < Z$

where  $N \rightarrow$  No. of poles  $\_P'$

$M \rightarrow$  No. of zeros  $\_Z'$

- Centroid is the centre of asymptotes. It is given by

$$\sigma_c = \frac{\sum P - \sum Z}{N - M}$$

- Angle of asymptotes is denoted by

$$\phi = \frac{(2K + 1)}{N - M} \times 180^\circ$$

☞ Breakaway/saddle point is the point at which the root locus comes out of the real axis.  
To find breakaway point

$$\text{Put } \frac{dK}{ds} = 0$$

- Angle of departure is tangent to root locus at complex

$$\phi_d = 180^\circ - (\phi_p - \phi_z)$$

Angle of arrival is tangent to the root locus at the complex zero.

$$\phi_a = 180^\circ - (\phi_z - \phi_p)$$

Where  $\phi_z =$  sum of all angles subtended by remaining zeros,

$\phi_p =$  sum of all angles subtended by remaining poles.

Based on the pole and zero distributions of an open-loop system the stability of the closed-loop system can be discussed as a function of one scalar parameter. The root-locus method shown in this module is a technique that can be used as a tool to design control systems. The basic ideas and its relevancy to control system design are introduced and illustrated. Ten general rules for constructing root loci for positive and negative gain are shortly presented such that they can be easily applied. This is demonstrated by some discussed examples, by a table with sixteen examples and by a comprehensive design of a closed-loop system of higher order.

**Example Problems:**

Consider the example

$$G_0(s) = \frac{K_0}{s(s+2)} = \frac{k_0}{(s-s_{P_1})(s-s_{P_2})}$$

with  $s_{P_1} = 0$ ,  $s_{P_2} = -2$  and  $k_0 = K_0$ . The poles of the closed-loop transfer function

$$G_W(s) = \frac{K_0}{s^2 + 2s + K_0}$$

are the roots  $s_1$  and  $s_2$  of the characteristic equation

$$P(s) = s^2 + 2s + K_0 = 0$$

and are given by

$$s_{1,2} = -1 \pm \sqrt{1 - K_0}$$

As  $s_1 = s_{P_1} = 0$  and  $s_2 = s_{P_2} = -2$  it can be seen that for  $K_0 = 0$  the poles of the closed loop transfer function are identical with those of the open-loop transfer function  $G_0(s)$ . For other values  $K_0$  the following two cases are considered:

a)

$K_0 \leq 1$ : Both roots  $s_1$  and  $s_2$  are real and lie on the real axis in the range of  $-2 \leq \sigma \leq -1$  and  $-1 \leq \sigma \leq 0$ ;

b)

$K_0 > 1$ : The roots  $s_1$  and  $s_2$  are conjugate complex with the real part  $\text{Re } s_{1,2} = -1$ , which does not depend on  $K_0$ , and the imaginary part  $s_{1,2} = \pm \sqrt{K_0 - 1}$ .

The curve has two branches as shown in Figure 6.2.

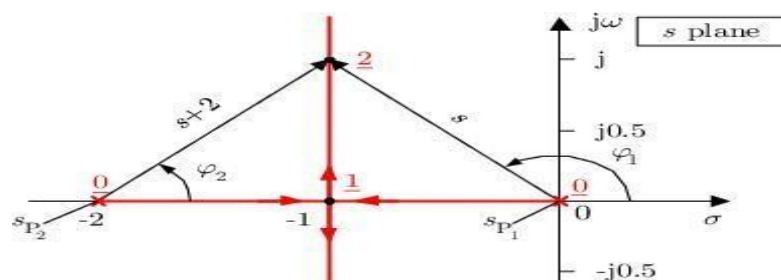



S J P N Trust's

**Hirasugar Institute of Technology, Nidasoshi.**

*Inculcating Values, Promoting Prosperity*

Approved by AICTE, Recognized by Govt. of Karnataka and Affiliated to VTU Belagavi.

**Mechanical**

**Academic**

**Notes**

**Control Engineering-  
15ME73**

**Figure 5.2:** Root locus of a simple second-order system



At  $(s_{P_1} + s_{P_2})/2 = -1$  is the *breakaway point* of the two branches. Checking the angle condition the condition

$$\varphi(s) = \arg\{G(s)\} = \arg\left\{\frac{1}{s(s+2)}\right\} = -\arg s - \arg(s+2) \stackrel{!}{=} \pm 180^\circ(2k+1)$$

must be valid. The complex numbers  $s$  and  $(s+2)$  have the angles  $\varphi_1$  and  $\varphi_2$  and the magnitudes  $|s|$  and  $|s+2|$ . The triangle  $(-2, 0, -1+j)$  in Figure 6.2 yields the angle condition. Evaluating the magnitude condition according to Eq. (6.8)

$$|G(s)| = \left|\frac{1}{s(s+2)}\right| = \frac{1}{K_0}$$

one obtains the value  $K_0$  on the root locus. E.g. for  $s = -1+j$  the gain of the open loop is  $K_0 = |s(s+2)|_{s=-1+j} = 2$ .

The value of  $K_0$  at the breakaway point  $s_B = -1$  is  $K_0 = |-1(-1+2)| = 1$ .

Table 5.1 shows further examples of some 1st- and 2nd-order systems.

Table 5.1: Root loci of 1st- and 2nd-order systems			
$G_0(s)$	root locus	$G_0(s)$	root locus
$\frac{k_0}{s}$		$\frac{k_0}{(s + \sigma_1)^2 + \omega_1^2}$	
$\frac{k_0}{s^2}$		$\frac{k_0}{(s - s_{P_1})(s - s_{P_2})}$	
$\frac{k_0}{s - s_{P_1}}$		$\frac{k_0(s - s_{Z_1})}{(s - s_{P_1})} \quad  s_{Z_1}  >  s_{P_1} $	
$\frac{k_0}{s^2 + \omega_1^2}$		$\frac{k_0(s - s_{Z_1})}{(s - s_{P_1})} \quad  s_{Z_1}  <  s_{P_1} $	



### 5.3. General rules for constructing root loci

To facilitate the application of the root-locus method for systems of higher order than 2nd, rules can be established. These rules are based upon the interpretation of the angle condition and the analysis of the characteristic equation. The rules presented aid in obtaining the root locus by expediting the manual plotting of the locus. But for automatic plotting using a computer these rules provide checkpoints to ensure that the solution is correct.

Though the angle and magnitude conditions can also be applied to systems having dead time, in the following we restrict to the case of the open-loop rational transfer functions according to Eq. (5.3)

$$G_0(s) = k_0 \frac{(s - s_{Z_1})(s - s_{Z_2}) \dots (s - s_{Z_m})}{(s - s_{P_1})(s - s_{P_2}) \dots (s - s_{P_n})}, \quad k_0 \geq 0 \quad (5.11)$$

or

$$G_0(s) = k_0 \frac{b_0 + b_1s + \dots + b_{m-1}s^{m-1} + s^m}{a_0 + a_1s + \dots + a_{n-1}s^{n-1} + s^n} = k_0 \frac{N_0(s)}{D_0(s)} \quad (5.12)$$

As this transfer function can be written in terms of poles and zeros  $s_{P_\nu}$  and  $s_{Z_\mu}$  ( $\nu = 1, 2, \dots, n$ ;  $\mu = 1, 2, \dots, m$ )  $G_0(s)$  can be represented by their magnitudes and angles

$$G_0(s) = k_0 \frac{|s - s_{Z_1}| e^{j\varphi_{Z_1}} |s - s_{Z_2}| e^{j\varphi_{Z_2}} \dots |s - s_{Z_m}| e^{j\varphi_{Z_m}}}{|s - s_{P_1}| e^{j\varphi_{P_1}} |s - s_{P_2}| e^{j\varphi_{P_2}} \dots |s - s_{P_n}| e^{j\varphi_{P_n}}}$$

or

$$G_0(s) = k_0 \frac{\prod_{\mu=1}^m |s - s_{Z_\mu}|}{\prod_{\nu=1}^n |s - s_{P_\nu}|} e^{j \left( \sum_{\mu=1}^m \varphi_{Z_\mu} - \sum_{\nu=1}^n \varphi_{P_\nu} \right)} \quad (5.13)$$

From Eq. (5.8) the *magnitude condition*

$$\frac{\prod_{\mu=1}^m |s - s_{Z_\mu}|}{\prod_{\nu=1}^n |s - s_{P_\nu}|} = \frac{1}{k_0} \quad (5.14)$$

and from Eq. (5.9) the *angle condition*

$$\varphi(s) = \sum_{\mu=1}^m \varphi_{Z_\mu} - \sum_{\nu=1}^n \varphi_{P_\nu} = \pm 180^\circ (2k + 1) \quad k = 0, 1, 2, \dots \quad (5.15)$$



S J P N Trust's

**Hirasugar Institute of Technology, Nidasoshi.**

*Inculcating Values, Promoting Prosperity*

Approved by AICTE, Recognized by Govt. of Karnataka and Affiliated to VTU Belagavi.

**Mechanical**

**Academic**

**Notes**

**Control Engineering-  
15ME73**

for



follows. Here  $\varphi_{Z_\mu}$  and  $\varphi_{P_\nu}$  denote the angles of the complex values  $(s - s_{Z_\mu})$  and  $(s - s_{P_\nu})$ , respectively. All angles are considered positive, measured in the counterclockwise sense. If for each point the sum of these angles in the  $s$ -plane is calculated, just those particular points that fulfil the condition in Eq. (5.15) are points on the root locus. This principle of constructing a root-locus curve - as shown in Figure 5.3 - is mostly used for automatic root-locus plotting.

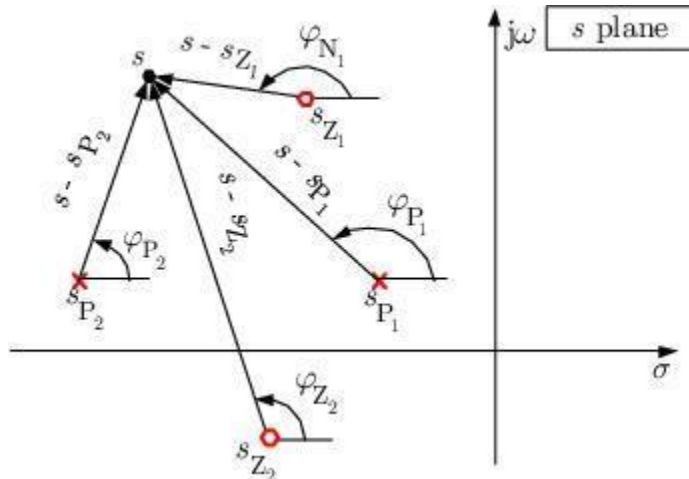

Figure 5.3: Pole-zero diagram for construction of the root locus

In the following the most important rules for the construction of root loci for  $k_0 > 0$  are listed:

**Rule 1 Symmetry**

As all roots are either real or complex conjugate pairs so that the root locus is symmetrical to the real axis.

**Rule 2 Number of branches**

The number of branches of the root locus is equal to the number of poles  $n$  of the open-loop transfer function.

**Rule 3 Locus start and end points**

The locus starting points ( $k_0 = 0$ ) are at the open-loop poles and the locus ending points ( $k_0 = \infty$ ) are at the open-loop zeros.  $(n - m)$  branches end at infinity. The number of starting branches from a pole and ending branches at a zero is equal to the multiplicity of the poles and zeros, respectively. A point at infinity is considered as an equivalent zero of multiplicity equal to  $n - m$ .

**Rule 4 Real axis locus**

If the total number of poles and zeros to the right of a point on the real axis is odd, this point lies on the locus.

**Rule 5 Asymptotes**

There are  $n - m$  asymptotes of the root locus with a slope of

$$\alpha_k = \arg s = \frac{\pm 180^\circ(2k + 1)}{n - m} \tag{5.16}$$





For  $(n - m) = 1, 2, 3$  and 4 one obtains the asymptote configurations as shown in Figure 5.4.

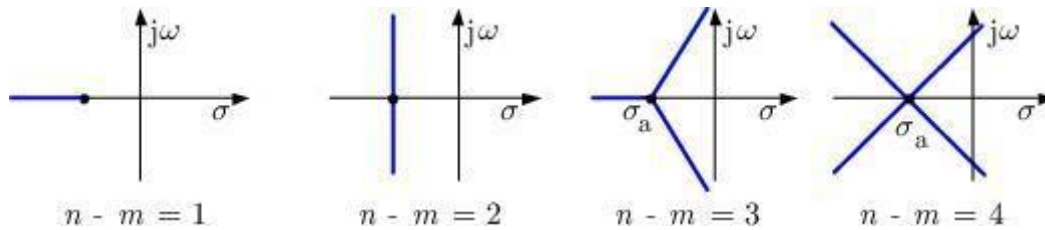

Figure 5.4: Asymptote configurations of the root locus

**Rule 6 Real axis intercept of the asymptotes**

The real axis crossing  $(\sigma_a, j0)$  of the asymptotes is at

$$\sigma_a = \frac{1}{n - m} \left\{ \sum_{\nu=1}^n \text{Re } s_{P_\nu} - \sum_{\mu=1}^m \text{Re } s_{Z_\mu} \right\} \quad (5.17)$$

**Rule 7 Breakaway and break-in points on the real axis**

At least one breakaway or break-in point  $(\sigma_B, j0)$  exists if a branch of the root locus is on the real axis between two poles or zeros, respectively. Conditions to find such real points are based on the fact that they represent multiple real roots. In addition to the characteristic equation (6.1) for multiple roots the condition

$$\frac{d}{ds} [1 + G_0(s)] = \frac{d}{ds} G_0(s) = 0 \quad (5.18)$$

must be fulfilled, which is equivalent to

$$\sum_{\nu=1}^n \frac{1}{s - s_{P_\nu}} = \sum_{\mu=1}^m \frac{1}{s - s_{Z_\mu}} \quad (5.19)$$

for  $s = \sigma_B$ . If there are no poles or zeros, the corresponding sum is zero.

**Rule 8 Complex pole/zero angle of departure/entry**

The angle of departure of pairs of poles with multiplicity  $r_{P_\rho}$  is

$$\varphi_{P_\rho, D} = \frac{1}{r_{P_\rho}} \left\{ - \sum_{\substack{\nu=1 \\ \nu \neq \rho}}^n \varphi_{P_\nu} + \sum_{\mu=1}^m \varphi_{Z_\mu} \pm 180^\circ(2k + 1) \right\} \quad (6.20)$$

and the angle of entry of the pairs of zeros with multiplicity  $r_{Z_\rho}$



$$\varphi_{Z_e, E} = \frac{1}{r_{Z_e}} \left\{ - \sum_{\substack{\mu=1 \\ \mu \neq e}}^m \varphi_{Z_\mu} + \sum_{\nu=1}^n \varphi_{P_\nu} \pm 180^\circ(2k+1) \right\} \quad (5.21)$$

**Rule 9 Root-locus calibration**

The labels of the values of  $k_0$  can be determined by using

$$k_0 = \frac{\prod_{\nu=1}^n |s - s_{P_\nu}|}{\prod_{\mu=1}^m |s - s_{Z_\mu}|} \quad (5.22)$$

For  $m = 0$  the denominator is equal to one.

**Rule 10 Asymptotic stability**

The closed loop system is asymptotically stable for all values of  $k_0$  for which the locus lies in the left-half  $s$  plane. From the imaginary-axis crossing points the critical values  $k_{0crit}$  can be determined.

The rules shown above are for positive values of  $k_0$ . According to the angle condition of Eq. (5.10) for negative values of  $k_0$  some rules have to be modified. In the following these rules are numbered as above but labelled by a \*.

**Rule 3\* Locus start and end points**

The locus starting points ( $k_0 = 0$ ) are at the open-loop poles and the locus ending points ( $k_0 = -\infty$ ) are at the open-loop zeros.  $(n - m)$  branches end at infinity. The number of starting branches from a pole and ending branches at a zero is equal to the multiplicity of the poles and zeros, respectively. A point at infinity is considered as an equivalent zero of multiplicity equal to  $n - m$ .

**Rule 4\* Real axis locus**

If the total number of poles and zeros to the right of a point on the real axis is even including zero, this point lies on the locus.

**Rule 5\* Asymptotes**

There are  $n - m$  asymptotes of the root locus with a slope of

$$\alpha_k = \arg s = \frac{\pm 360^\circ k}{n - m} \quad (5.23)$$

**Rule 8\* Complex pole/zero angle of departure/entry**

The angle of departure of pairs of poles with multiplicity  $r_{P_e}$  is

$$\varphi_{P_e, D} = \frac{1}{r_{P_e}} \left\{ - \sum_{\substack{\nu=1 \\ \nu \neq e}}^n \varphi_{P_\nu} + \sum_{\mu=1}^m \varphi_{Z_\mu} \pm 360^\circ k \right\} \quad (5.24)$$

and the angle of entry of the pairs of zeros with multiplicity  $r_{Z_e}$

$$\varphi_{Z_e, E} = \frac{1}{r_{Z_e}} \left\{ - \sum_{\substack{\mu=1 \\ \mu \neq e}}^m \varphi_{Z_\mu} + \sum_{\nu=1}^n \varphi_{P_\nu} \pm 360^\circ k \right\} \quad (5.25)$$

The root-locus method can also be applied for other cases than varying  $k_0$ . This is possible as long as  $G_0(s)$  can be rewritten such that the angle condition according to Eq. (5.15) and the rules given above can be applied. This will be demonstrated in the following two examples.

Given the closed-loop characteristic equation

$$a_0 + a_1 s + \dots + a_{n-1} s^{n-1} + s^n = 0,$$

the root locus for varying the parameter  $\alpha_1$  is required. The characteristic equation is therefore rewritten as

$$1 + \alpha_1 \frac{s}{a_0 + a_2 s^2 + \dots + s^n} = 0.$$

This form then corresponds to the standard form

$$1 + G_0(s) = 1 + \alpha_1 \frac{N_0(s)}{D_0(s)} = 0$$

to which the rules can be applied. ■

Given the closed-loop characteristic equation

$$s^3 + (3 + \alpha) s^2 + 2s + 1 = 0,$$



it is required to find the effect of the parameter on the position of the closed-loop poles. The equation is rewritten into the desired form

$$1 + \alpha \frac{s^2}{s^3 + 3s^2 + 2s + 4} = 0$$

Using the rules 1 to 10 one can easily predict the geometrical form of the root locus based on the distribution of the open-loop poles and zeros. Table 6.2 shows some typical distributions of open-loop poles and zeros and their root loci.

**Table 6.2:** Typical distributions of open-loop poles and zeros and the root loci

No.	root locus	No.	root locus
1		9	
2		10	
3		11	
4		12	
5		13	
6		14	
7		15	
8		16	



For the qualitative assessment of the root locus one can use a physical analogy. If all open-loop poles are substituted by a negative electrical charge and all zeros by a commensurate positive one and if a massless negative charged particle is put onto a point of the root locus, a movement is observed. The path that the particle takes because of the interplay between the repulsion of the poles and the attraction of the zeros lies just on the root locus. Comparing the root locus examples 3 and 9 of Table 5.2 the 'repulsive' effect of the additional pole can be clearly seen.

The systematic application of the rules from section 5.2 for the construction of a root locus is shown in the following non-trivial example for the open-loop transfer function

$$G_0(s) = \frac{k_0(s+1)}{s(s+2)(s^2+12s+40)} \tag{5.26}$$

The degree of the numerator polynomial is  $m = 1$ . This means that the transfer function has one zero ( $s_{z_1} = -1$ ). The degree of the denominator polynomial is  $n = 4$  and we have the four poles ( $s_{p_1} = 0$ ,  $s_{p_2} = -2$ ,  $s_{p_3} = -6 + j2$ ,  $s_{p_4} = -6 - j2$ ). First the poles (x) and the zeros (o) of the open loop are drawn on the  $s$  plane as shown in Figure 5.5. According to rule 3 these poles are just

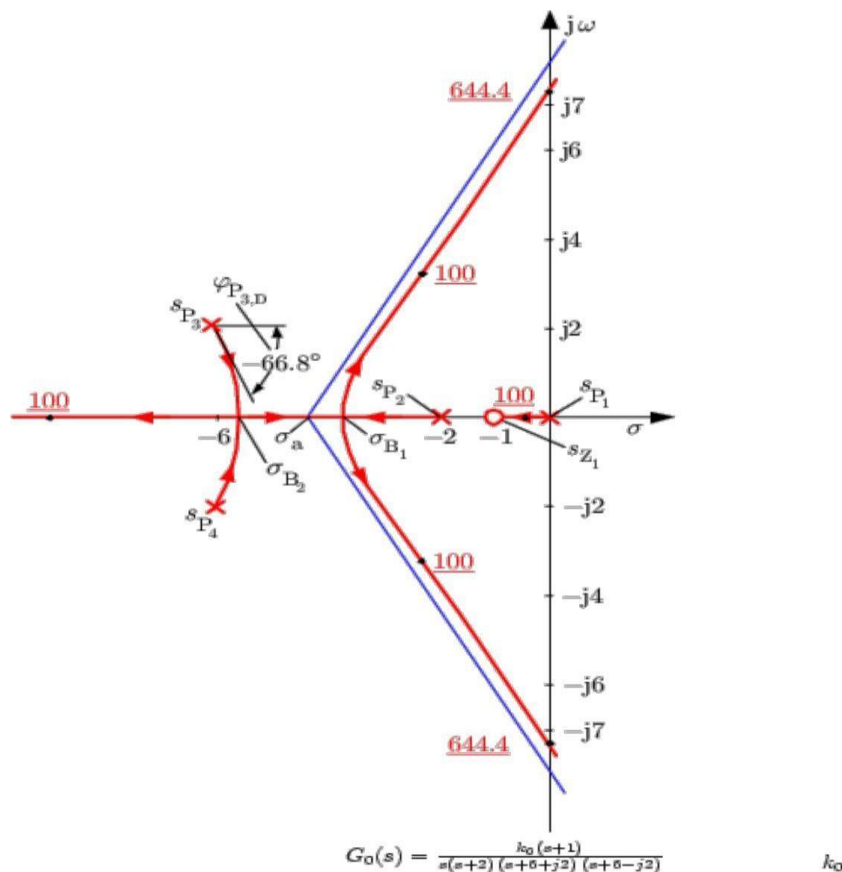



**Figure 5.5:** Root locus of  $G(s) = \frac{1}{s(s+2)(s+6-j2)(s+6+j2)}$ . Values of  $k_0$  are in red and underlined.

those points of the root locus where  $k_0 = 0$  and the zeros where  $k_0 \rightarrow \infty$ . We have  $(n - m) = 3$  branches that go to infinity and the asymptotes of these three branches are lines which intercept the real axis according to rule 6. From Eq. (5.17) the crossing is at

$$\sigma_a = \frac{(0 - 2 - 6 - 6) - (-1)}{3} = -\frac{13}{3} = -4.33 \quad (5.27)$$

and the slopes of the asymptotes are according to Eq. (5.16)

$$\alpha_k = \frac{\pm 180^\circ(2k + 1)}{3} = \pm 60^\circ(2k + 1) \quad k = 0, 1, 2, \dots \quad (5.28)$$

i.e.  $\alpha_0 = 60^\circ, \quad \alpha_1 = +180^\circ, \quad \alpha_2 = -60^\circ$

The asymptotes are shown in Figure 5.5 as blue lines. Using Rule 4 it can be checked which points on the real axis are points on the root locus. The points  $\sigma$  with  $-1 < \sigma < 0$  and  $\sigma < -2$  belong to the root locus, because to the right of them the number of poles and zeros is odd. According to rule 7 breakaway and break-in points can only occur pairwise on the real axis to the left of -2. These points are real solutions of the Eq. (5.19). Here we have

$$\frac{1}{s} + \frac{1}{s+2} + \frac{1}{s+6-j2} + \frac{1}{s+6+j2} = \frac{1}{s+1} \quad (5.29)$$

or

$$3s^4 + 32s^3 + 106s^2 + 128s + 80 = 0$$

This equation has the solutions  $s_{B_1} = -3.68, \quad s_{B_2} = -5.47$  and  $s_{B_{3,4}} = -0.76 \pm j0.866$ . The real roots  $s_{B_1} = -3.68$  and  $s_{B_2} = -5.47$  are the positions of the breakaway and the break-in point.

The angle of departure  $\varphi_{P_3,D}$  of the root locus from the complex pole at  $s_{P_3} = -6 + j2$  can be determined from Figure 5.6 according to Eq. (5.20):

$$\begin{aligned} \varphi_{P_3,D} &= -90^\circ - 153.4^\circ - 161.6^\circ + 158.2^\circ \pm 180^\circ(2k + 1) \\ &= -246.8^\circ + 180^\circ = -66.8^\circ \end{aligned} \quad (5.30)$$

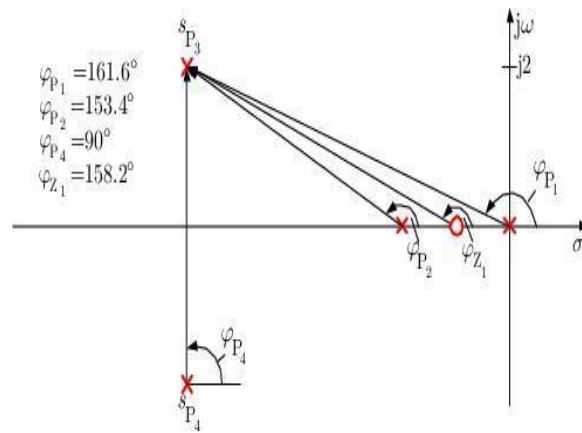

**Figure 5.6:** Calculating the angle of departure  $\varphi_{P_3,D}$  of the complex pole  $s_{P_3} = -6 + j2$

With this specifications the root locus can be sketched. Using rule 9 the value of  $k_0$  can be determined for some selected points. The value at the intersection with the imaginary axis is

$$k_{0,crit} = \frac{7.2 \cdot 7.4 \cdot 7.9 \cdot 11.1}{7.25} = 644.4$$

### OUTCOMES:

At the end of the unit, the students are able to:

- Construct root loci from open loop transfer functions of control systems and Analyze the behaviour of roots with system gain.
- Assess the stability of closed loop systems by means of the root location in s-plane and their effects on system performance.

### SELF-TEST QUESTIONS:

1. Sketch the root locus for  $G(S)H(S) = \frac{K}{S(S+2)(S+4)}$  show all details on it.
2. Sketch the root locus for  $G(S)H(S) = \frac{10K}{S(S+2)(S+6)}$  show all details on it.
3. Sketch the root locus for  $G(S)H(S) = \frac{K(S+1)}{S(S+2)(S+4)}$  show all details on it.

### FURTHER READING:

1. **Modern Control Systems**, Richard.C.Dorf and Robert.H.Bishop, Addison Wesley,1999
2. **System dynamics & control**, Eronini-Umez, Thomson Asia pte Ltd. singapore, 2002.
3. **Feedback Control System**, Schaum's series. 2001.

	S J P N Trust's	<b>Mechanical</b>
	<b>Hirasugar Institute of Technology, Nidasoshi.</b>	<b>Academic</b>
	<i>Inculcating Values, Promoting Prosperity</i>	<b>Notes</b>
	Approved by AICTE, Recognized by Govt. of Karnataka and Affiliated to VTU Belagavi.	<b>Control Engineering-15ME73</b>

## Module-5

# SYSTEM COMPENSATION

## LESSON STRUCTURE:

### Introduction:

### System Compensation

### Basic Characteristics of Lead, Lag And Lag-Lead Compensation:

### Lag Compensator

### Lead Compensator

### Lag-Lead Compensator

## OBJECTIVES:

- In order to obtain the desired performance of the system, we use compensating networks. Compensating networks are applied to the system in the form of feed forward path gain adjustment.
- To demonstrate to compensate a unstable system to make it stable.

### Introduction:

Automatic control systems have played a vital role in the advancement of science and engineering. In addition to its extreme importance in sophisticated systems in Space vehicles, missile- guidance, aircraft navigating systems, etc., automatic control system as become an important and integral part of manufacturing and industrial processes. Control of process parameters like pressure, temperature, flow, viscosity, speed, humidity, etc., in process engineering and tooling, handling and assembling mechanical parts in manufacturing industries among others in engineering field where automatic control systems are inevitable part of the system.

A control system is designed and constructed to perform specific functional task. The concept of control system design starts by defining the output variable( Speed, Pressure, Temperature Etc.) and then determining the required specification ( Stability, Accuracy, and speed of response). In the design process the designs must first select the control Media and then the control elements to meet the designed ends.

In actual practice several alternative can be analyzed and a final judgment can be made an



	S J P N Trust's	<b>Mechanical</b>
	<b>Hirasugar Institute of Technology, Nidasoshi.</b>	<b>Academic</b>
	<i>Inculcating Values, Promoting Prosperity</i>	<b>Notes</b>
	Approved by AICTE, Recognized by Govt. of Karnataka and Affiliated to VTU Belagavi.	<b>Control Engineering- 15ME73</b>

overall performances and economy.



S J P N Trust's

**Hirasugar Institute of Technology, Nidasoshi.**

*Inculcating Values, Promoting Prosperity*

Approved by AICTE, Recognized by Govt. of Karnataka and Affiliated to VTU Belagavi.

**Mechanical**

**Academic**

**Notes**

**Control  
Engineering-  
15ME73**

Systems have been categorized as manual and automatic systems. Based on the type of control needed most systems are categorized as - Manual & Automatic. In applications where systems are to be operated with limited or no supervision, then systems are made automatic and where system needs supervision the system is designed as manual. In the present-day context most of the systems are designed as automatic systems for which one of the important considerations was economics. However, the necessity for the system to be made as an automatic system is to make sure that the system performs with no scope for error which otherwise is prone to a lot of errors especially in the operations. Other classification of a system is based on the input and output relationships. Accordingly, in an Open Loop Control System the output is independent of the input and in a closed loop control system the output is dependant on the input.

The term input refers to reference variable and the output is referred to as Controlled variable. Most of the systems are designed as closed loop systems where a feedback path with an element with a transfer function would help in bridging the relationship between the input and the output. A system can be represented by the block diagram and from a simple to a complicated system, reduction techniques can be used to obtain the overall transfer function of the system. Overall system Transfer function can also be obtained by another technique using signal flow analysis where the transfer function of the system is obtained from Mason's gain formula. Once the system is designed, the response of the system may be obtained based on the type of input. This is studied in two categories of response namely response of the system in time domain and frequency domain. The system thus conceived and designed needs to be analyzed based on the same domains. At this stage the systems are studied from the point of view of its operational features like Stability, Accuracy and Speed of Response. Development of various systems have been continuous and the history of the same go back to the old WATT'S

Speed Governor, which was considered as an effective means of speed regulation. Other control system examples are robot arm, Missile Launching and Guidance System, Automatic Aircraft Landing System, Satellite based digital tracking systems, etc to name a few. In the design of the control systems, three important requirements are considered namely STABILITY, ACCURACY and SPEED OF RESPONSE.

Stable Systems are those where response to input must reach and maintain some useful value within a reasonable period of time. The designed systems should both be Unstable

Systems as unstable control systems produce persistent or even violent oscillations of the output



S J P N Trust's

# Hirasugar Institute of Technology, Nidasoshi.

*Inculcating Values, Promoting Prosperity*

Approved by AICTE, Recognized by Govt. of Karnataka and Affiliated to VTU Belagavi.

**Mechanical**

**Academic**

**Notes**

**Control  
Engineering-  
15ME73**

and output will be driven to some extreme limiting value.



Systems are also designed to meet certain levels of **Accuracy**. **This is a** relative term with limits based upon a particular application. A time measurement system may be from a simple watch to a complicated system used in the sports arena. But the levels of accuracy are different in both cases. One used in sports arena must have very high levels of sophistication and must be reliable showing no signs of variations. However, this feature of the system is purely based on the system requirement. For a conceived, designed and developed system, the higher the levels of Accuracy expected, higher is the Cost.

The third important requirement comes by way of **SPEED OF RESPONSE**. System must complete its response to some input within an acceptable period of time. System has no value if the time required to respond fully to some input is far greater than the time interval between inputs

### System Compensation

Compensation is the minor adjustment of a system in order to satisfy the given specifications. Specification refers to the objective of a system to perform and obtain the expected output after the system is provided with a proper input. Some of the needs of the system compensation are as specified.

### Basic Characteristics Of Lead, Lag And Lag-Lead Compensation:

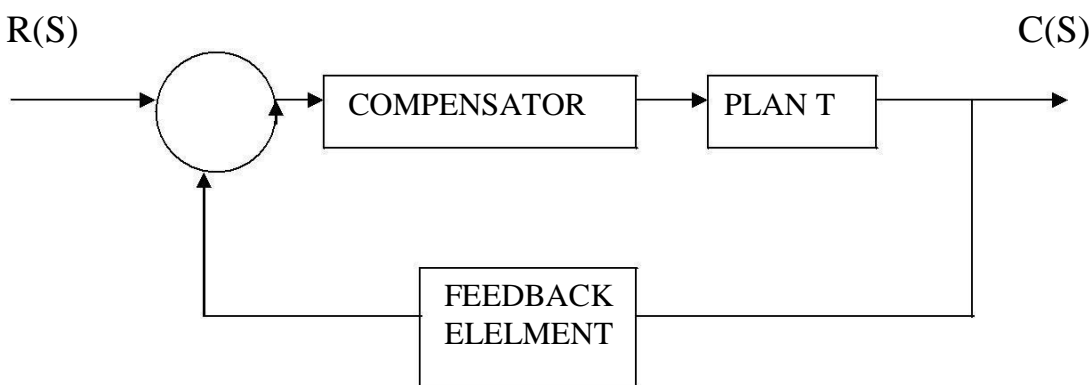

Lead compensation essentially yields an appropriate improvement in transient response and a small improvement in steady state accuracy. Lag compensation on the other hand, yields an appreciable improvement in steady state accuracy at the expense of increasing the transient response time. Lag-lead compensation combines the characteristics of both lead compensation and lag compensation. The use of a lag-lead compensator raises the order of the system by two



S J P N Trust's

# Hirasugar Institute of Technology, Nidasoshi.

*Inculcating Values, Promoting Prosperity*

Approved by AICTE, Recognized by Govt. of Karnataka and Affiliated to VTU Belagavi.

**Mechanical**

**Academic**

**Notes**

**Control  
Engineering-  
15ME73**

(unless cancellation occurs between the zeroes of the lag- lead network and the poles of the



uncompensated open-loop transfer function), which means that the system becomes more complex and it is more difficult to control the transient response behavior. The particular situation determines the type of the compensation to be used.

## Lag Compensator

The Lag Compensator is an electrical network which produces a sinusoidal output having the phase lag when a sinusoidal input is applied. The lag compensator circuit in the 's' domain is shown in the following figure.

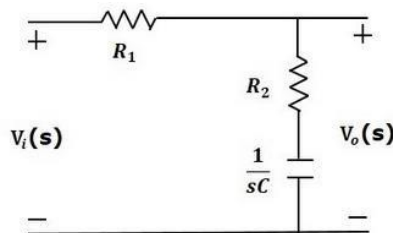

Here, the capacitor is in series with the resistor  $R_2$  and the output is measured across this combination.

The transfer function of this lag compensator is –

$$\frac{V_o(s)}{V_i(s)} = \frac{1}{\alpha} \left( \frac{s + \frac{1}{\tau}}{s + \frac{1}{\alpha\tau}} \right)$$

Where,

$$\tau = R_2 C$$

$$\alpha = \frac{R_1 + R_2}{R_2}$$

From the above equation,  $\alpha$  is always greater than one. We know that, the phase of the output sinusoidal signal is equal to the sum of the phase angles of input sinusoidal signal and the transfer function. So, in order to produce the phase lag at the output of this compensator, the phase angle of the transfer function should be negative. This will happen when  $\alpha > 1$ .

## Lead Compensator

The lead compensator is an electrical network which produces a sinusoidal output having phase lead when a sinusoidal input is applied. The lead compensator circuit in the 's' domain is shown in the following figure.

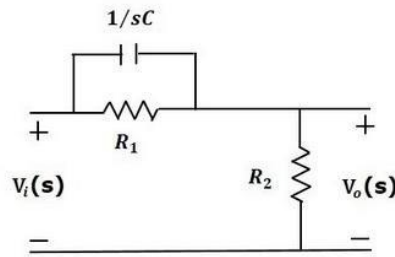

Here, the capacitor is parallel to the resistor  $R_1$  and the output is measured across resistor  $R_2$ . The transfer function of this lead compensator is –

$$\frac{V_o(s)}{V_i(s)} = \beta \left( \frac{s\tau + 1}{\beta s\tau + 1} \right)$$

Where,

$$\tau = R_1 C$$

$$\beta = \frac{R_2}{R_1 + R_2}$$

We know that, the phase of the output sinusoidal signal is equal to the sum of the phase angles of input sinusoidal signal and the transfer function. So, in order to produce the phase lead at the output of this compensator, the phase angle of the transfer function should be positive. This will happen when  $0 < \beta < 1$ . Therefore, zero will be nearer to origin in pole-zero configuration of the lead compensator.

### Lag-Lead Compensator

Lag-Lead compensator is an electrical network which produces phase lag at one frequency region and phase lead at other frequency region. It is a combination of both the lag and the lead compensators. The lag-lead compensator circuit in the 's' domain is shown in the following figure.

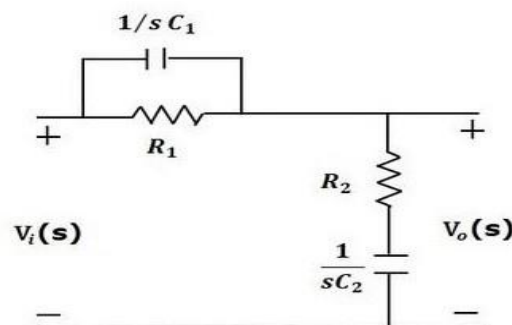

This circuit looks like both the compensators are cascaded. So, the transfer function of this

	S J P N Trust's	<b>Mechanical</b>
	<b>Hirasugar Institute of Technology, Nidasoshi.</b>	<b>Academic</b>
	<i>Inculcating Values, Promoting Prosperity</i>	<b>Notes</b>
	Approved by AICTE, Recognized by Govt. of Karnataka and Affiliated to VTU Belagavi.	<b>Control Engineering-15ME73</b>

circuit will be the product of transfer functions of the lead and the lag compensators.





$$\frac{V_o(s)}{V_i(s)} = \beta \left( \frac{s\tau_1 + 1}{\beta s\tau_1 + 1} \right) \frac{1}{\alpha} \left( \frac{s + \frac{1}{\tau_2}}{s + \frac{1}{\alpha\tau_2}} \right)$$

We know  $\alpha\beta = 1$ .

$$\Rightarrow \frac{V_o(s)}{V_i(s)} = \left( \frac{s + \frac{1}{\tau_1}}{s + \frac{1}{\beta\tau_1}} \right) \left( \frac{s + \frac{1}{\tau_2}}{s + \frac{1}{\alpha\tau_2}} \right)$$

Where,

$$\tau_1 = R_1 C_1$$

$$\tau_2 = R_2 C_2$$

### OUTCOMES:

At the end of the unit, the students are able to:

- obtain the desired performance of the system, we use compensating networks. Compensating networks are applied to the system in the form of feed forward path gain adjustment.
- Differentiate different types of compensators.

### SELF-TEST QUESTIONS:

1. Define compensators. What is the need of compensators in a system.
2. Explain with a sketch Lag compensator.
3. Explain with a sketch Lead compensator.
4. Explain with a sketch Lag-Lead compensator.
5. Explain basic components of Lag - Lead compensator.

### FURTHER READING:

1. **Modern Control Systems**, Richard.C.Dorf and Robert.H.Bishop, Addison Wesley, 1999
2. **System dynamics & control**, Eronini-Umez, Thomson Asia pte Ltd. singapore, 2002.
3. **Feedback Control System**, Schaum's series. 2001.

Prepared by- Prof.M.R.Ingalagi

Asst. Professor Department of Mechanical Engineering, HIT,Nidasoshi