

MODULE-I
CONCEPTS OF MEASUREMENT

CONTENTS

- 1.1 GENERAL CONCEPT
 - 1.1.1 Introduction to Metrology
 - 1.1.2 Introduction to Measurement
 - 1.1.3 Types of Metrology
 - 1.2 OBJECTIVES OF METROLOGY
 - 1.2.1 Necessity and Importance of Metrology
 - 1.3 METHODS OF MEASUREMENTS
 - 1.4 GENERALIZED MEASUREMENT SYSTEM
 - 1.4.1 Units
 - 1.4.2 Standards
 - 1.4.3 Classification of Standards
 - 1.4.4 Accuracy of Measurements
 - 1.4.5 Precision
 - 1.4.6 Accuracy
 - 1.4.7 Distinction between Precision and Accuracy
 - 1.4.8 Factors affecting the accuracy of the measuring system
 - 1.5 SENSITIVITY
 - 1.5.1 Readability
 - 1.5.2 Calibration
 - 1.5.3 Repeatability
 - 1.5.4 Reproducibility
 - 1.6 STATIC AND DYNAMIC RESPONSE
 - 1.6.1 Zero-Order Instrument
 - 1.6.2 First-Order Instrument
 - 1.6.3 Second-Order Instrument
 - 1.7 ERRORS IN MEASUREMENTS
 - 1.7.1 Absolute Error
 - 1.7.2 Types of Errors
-

1.8 INTRODUCTION TO DIMENSIONAL AND GEOMETRIC TOLERANCE

1.9 INTERCHANGEABILITY



TECHNICAL TERMS

□ **Measurement**

Measurement is the act, or the result, of a quantitative comparison between a predetermined standard and an unknown magnitude.

□ **Range**

It represents the highest possible value that can be measured by an instrument.

□ **Scale sensitivity**

It is defined as the ratio of a change in scale reading to the corresponding change in pointer deflection. It actually denotes the smallest change in the measured variable to which an instrument responds.

□ **True or actual value**

It is the actual magnitude of a signal input to a measuring system which can only be approached and never valued.

□ **Accuracy**

It is defined as the closeness with which the reading approaches an accepted standard value or true value.

□ **Precision**

It is the degree of reproducibility among several independent measurements of the same true value under specified conditions. It is usually expressed in terms of deviation in measurement.

□ **Repeatability**

It is defined as the closeness of agreement among the number of consecutive measurement of the output for the same value of input under the same operating conditions. It may be specified in terms of units for a given period of time

□ **Reliability**

It is the ability of a system to perform and maintain its function in routine circumstances. Consistency of a set of measurements or measuring instrument often used to describe a test.

□ **Systematic Errors**

A constant uniform deviation of the operation of an instrument is known as systematic error. Instrumentational error, environmental error, Systematic error and observation error are systematic errors.

□ **Random Errors**

Some errors result through the systematic and instrument errors are reduced or at least accounted for. The causes of such errors are unknown and hence, the errors are called random errors.

□ **Calibration**

Calibration is the process of determining and adjusting an instrument's accuracy to make sure its accuracy is within the manufacturer's specifications.



1.1 GENERAL CONCEPT

1.1.1 Introduction to Metrology

Metrology word is derived from two Greek words such as metro which means measurement and logy which means science. Metrology is the science of precision measurement. The engineer can say it is the science of measurement of lengths and angles and all related quantities like width, depth, diameter and straightness with high accuracy. Metrology demands pure knowledge of certain basic mathematical and physical principles. The development of the industry largely depends on the engineering metrology. Metrology is concerned with the establishment, reproduction and conservation and transfer of units of measurements and their standards. Irrespective of the branch of engineering, all engineers should know about various instruments and techniques.

1.1.2 Introduction to Measurement

Measurement is defined as the process of numerical evaluation of a dimension or the process of comparison with standard measuring instruments. The elements of measuring system include the instrumentation, calibration standards, environmental influence, human operator limitations and features of the work-piece. The basic aim of measurement in industries is to check whether a component has been manufactured to the requirement of a specification or not.

1.1.3 Types of Metrology

□ Legal Metrology

'Legal metrology' is that part of metrology which treats units of measurements, methods of measurements and the measuring instruments, in relation to the technical and legal requirements. The activities of the service of 'Legal Metrology' are:

- (i) Control of measuring instruments;
-
-

- (ii) Testing of prototypes/models of measuring instruments;
- (iii) Examination of a measuring instrument to verify its conformity to the statutory requirements etc.

□ **Dynamic Metrology**

'Dynamic metrology' is the technique of measuring simultaneous variations of a continuous nature. The technique has proved very valuable, and record of continuous measurement, over a surface, for instance, has obvious advantages over individual measurements of an isolated character.

□ **Deterministic metrology**

Deterministic metrology is a new philosophy in which part measurement is replaced by process measurement. The new techniques such as 3D error compensation by CNC (Computer Numerical Control) systems and expert systems are applied, leading to fully adaptive control. This technology is used for very high precision manufacturing machinery and control systems to achieve micro technology and nanotechnology accuracies.

1.2 OBJECTIVES OF METROLOGY

Although the basic objective of a measurement is to provide the required accuracy at a minimum cost, metrology has further objectives in a modern engineering plant with different shapes which are:

1. Complete evaluation of newly developed products.
 2. Determination of the process capabilities and ensure that these are better than the relevant component tolerances.
 3. Determination of the measuring instrument capabilities and ensure that they are quite sufficient for their respective measurements.
 4. Minimizing the cost of inspection by effective and efficient use of available facilities.
-
-

5. Reducing the cost of rejects and rework through application of Statistical Quality Control Techniques.
6. To standardize the measuring methods
7. To maintain the accuracies of measurement.
8. To prepare designs for all gauges and special inspection fixtures.

1.2.1 Necessity and Importance of Metrology

1. The importance of the science of measurement as a tool for scientific research (by which accurate and reliable information can be obtained) was emphasized by Galileo and Gvethe. This is essential for solving almost all technical problems in the field of engineering in general, and in production engineering and experimental design in particular. The design engineer should not only check his design from the point of view of strength or economical production, but he should also keep in mind how the dimensions specified can be checked or measured. Unfortunately, a considerable amount of engineering work is still being executed without realizing the importance of inspection and quality control for improving the function of product and achieving the economical production.

2. Higher productivity and accuracy is called for by the present manufacturing techniques. This cannot be achieved unless the science of metrology is understood, introduced and applied in industries. Improving the quality of production necessitates proportional improvement of the measuring accuracy, and marking out of components before machining and the in-process and post process control of the dimensional and geometrical accuracies of the product. Proper gauges should be designed and used for rapid and effective inspection. Also automation and automatic control, which are the modern trends for future developments, are based on measurement. Means for automatic

gauging as well as for position and displacement measurement with feedback control have to be provided.

1.3 METHODS OF MEASUREMENTS

These are the methods of comparison used in measurement process. In precision measurement various methods of measurement are adopted depending upon the accuracy required and the amount of permissible error.

The methods of measurement can be classified as:

1. Direct method
2. Indirect method
3. Absolute or Fundamental method
4. Comparative method
5. Transposition method
6. Coincidence method
7. Deflection method
8. Complementary method
9. Contact method
10. Contact less method

1. Direct method of measurement:

This is a simple method of measurement, in which the value of the quantity to be measured is obtained directly without any calculations. For example, measurements by using scales, vernier callipers, micrometers, bevel protector etc. This method is most widely used in production. This method is not very accurate because it depends on human insensitiveness in making judgment.

2. Indirect method of measurement:

In indirect method the value of quantity to be measured is obtained by measuring other quantities which are functionally related to the required value. E.g. Angle measurement by sine bar, measurement of screw pitch diameter by three wire method etc.

3. Absolute or Fundamental method:

It is based on the measurement of the base quantities used to define the quantity. For example, measuring a quantity directly in accordance with the definition of that quantity, or measuring a quantity indirectly by direct measurement of the quantities linked with the definition of the quantity to be measured.

4. Comparative method:

In this method the value of the quantity to be measured is compared with known value of the same quantity or other quantity practically related to it. So, in this method only the deviations from a master gauge are determined, e.g., dial indicators, or other comparators.

5. Transposition method:

It is a method of measurement by direct comparison in which the value of the quantity measured is first balanced by an initial known value A of the same quantity, and then the value of the quantity measured is put in place of this known value and is balanced again by another known value B. If the position of the element indicating equilibrium is the same in both cases, the value of the quantity to be measured is $\frac{A}{B}$. For example, determination of mass by means of a balance and known weights, using the Gauss double weighing.

6. Coincidence method:

It is a differential method of measurement in which a very small difference between the value of the quantity to be measured and the reference is determined by the observation of the coincidence of certain lines or signals. For example, measurement by vernier calliper micrometer.

7. Deflection method:

In this method the value of the quantity to be measured is directly indicated by a deflection of a pointer on a calibrated scale.

8. Complementary method:

In this method the value of the quantity to be measured is combined with a known value of the same quantity. The combination is so adjusted that the sum of these two values is equal to predetermined comparison value. For example, determination of the volume of a solid by liquid displacement.

9. Method of measurement by substitution:

It is a method of direct comparison in which the value of a quantity to be measured is replaced by a known value of the same quantity, so selected that the effects produced in the indicating device by these two values are the same.

10. Method of null measurement:

It is a method of differential measurement. In this method the difference between the value of the quantity to be measured and the known value of the same quantity with which it is compared is brought to zero.

1.4 GENERALIZED MEASUREMENT SYSTEM

A measuring system exists to provide information about the physical value of some variable being measured. In simple cases, the system can consist of only a single unit that gives an output reading or signal according to the magnitude of the unknown

variable applied to it. However, in more complex measurement situations, a measuring system consists of several separate elements as shown in Figure 1.1.

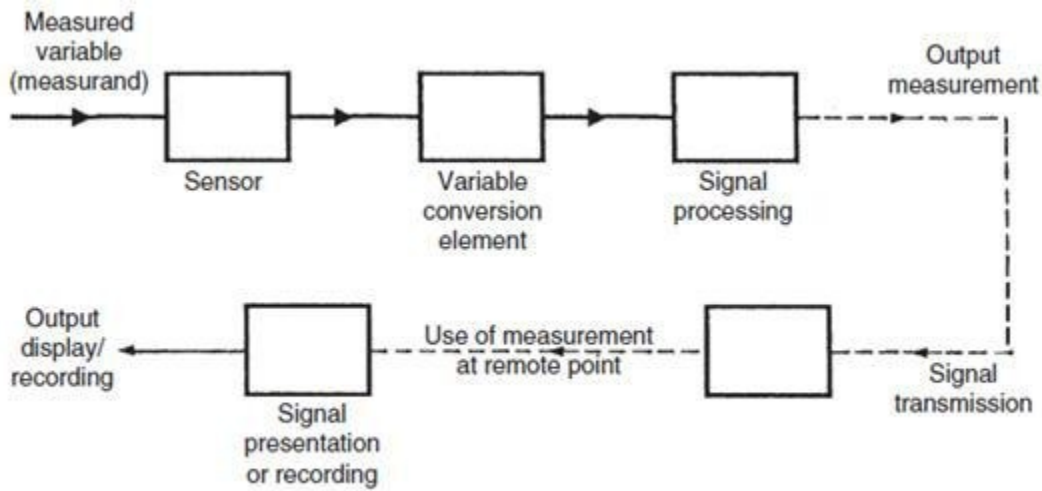

Fig 1.1 Generalised Measurement system

1.4.1 Units

Table 1.1 Physical Quantities and its unit

Physical Quantity	Standard Unit	Definition
Length	Meter	Length of path traveled by light in an interval of $1/299,792,458$ seconds
Mass	Kilogram	Mass of a platinum-iridium cylinder kept in the International Bureau of Weights and Measures, Sevres, Paris
Time	Second	9.192631770×10^9 cycles of radiation from vaporized cesium 133 (an accuracy of 1 in 10^{12} or one second in 36,000 years)
Temperature	Degrees	Temperature difference between absolute zero Kelvin and the triple point of water is defined as 273.16 K
Current	Ampere	One ampere is the current flowing through two infinitely long parallel conductors of negligible cross section placed 1 meter apart in vacuum and producing a force of 2×10^{-7} newtons per meter length of conductor
Luminous intensity	Candela	One candela is the luminous intensity in a given direction from a source emitting monochromatic radiation at a frequency of 540 terahertz ($\text{Hz} \times 10^{12}$) and with a radiant density in that direction of 1.4641 mW/steradian (1 steradian is the solid angle, which, having its vertex at the centre of a sphere, cuts off an area of the sphere surface equal to that of a square with sides of length equal to the sphere radius)
Matter	Mole	Number of atoms in a 0.012-kg mass of carbon 12

1.4.2 Standards

The term standard is used to denote universally accepted specifications for devices. Components or processes which ensure conformity and interchangeability throughout a particular industry. A standard provides a reference for assigning a numerical value to a measured quantity. Each basic measurable quantity has associated with it an ultimate standard. Working standards, those used in conjunction with the various measurement making instruments.

The national institute of standards and technology (NIST) formerly called National Bureau of Standards (NBS), it was established by an act of congress in 1901, and the need for such body had been noted by the founders of the constitution. In order to maintain accuracy, standards in a vast industrial complex must be traceable to a single source, which may be national standards.

The following is the generalization of echelons of standards in the national measurement system.

1. Calibration standards
2. Metrology standards
3. National standards

- 1. Calibration standards:** Working standards of industrial or governmental laboratories
 - 2. Metrology standards:** Reference standards of industrial or Governmental laboratories.
 - 3. National standards:** It includes prototype and natural phenomenon of SI (Systems International), the world wide system of weight and measures standards. Application of precise measurement has increased so much, that a single national laboratory to perform directly all the calibrations and standardization required by
-

a large country with high technical development. It has led to the establishment of a considerable number of standardizing laboratories in industry and various other areas. A standard provides a reference or datum for assigning a numerical value to a measured quantity.

1.4.3 Classification of Standards

To maintain accuracy and interchangeability it is necessary that Standards to be traceable to a single source, usually the National Standards of the country, which are further linked to International Standards. The accuracy of National Standards is transferred to working standards through a chain of intermediate standards in a manner given below.

- National Standards
- National Reference Standards
- Working Standards
- Plant Laboratory Reference Standards
- Plant Laboratory Working Standards
- Shop Floor Standards

Evidently, there is a gradation of accuracy in passing from the defining standards to the shop floor standards. The accuracy of particular standard depends on a combination of the number of times it has been compared with a standard in a higher echelon, the frequency of such comparisons, the care with which it was done, and the stability of the particular standards itself

1.4.4 Accuracy of Measurements

The purpose of measurement is to determine the true dimensions of a part. But no measurement can be made absolutely accurate. There is always some error. The amount of error depends upon the following factors:

- The accuracy and design of the measuring instrument
 - The skill of the operator
-
-

- Method adopted for measurement
- Temperature variations
- Elastic deformation of the part or instrument etc.

Thus, the true dimension of the part cannot be determined but can only be approximate. The agreement of the measured value with the true value of the measured quantity is called accuracy. If the measurement of dimensions of part approximates very closely to the true value of that dimension, it is said to be accurate. Thus the term accuracy denotes the closeness of the measured value with the true value. The difference between the measured value and the true value is the error of measurement. The lesser the error, more is the accuracy.

1.4.5 Precision

The terms precision and accuracy are used in connection with the performance of the instrument. Precision is the repeatability of the measuring process. It refers to the group of measurements for the same characteristics taken under identical conditions. It indicates to what extent the identically performed measurements agree with each other. If the instrument is not precise it will give different (widely varying) results for the same dimension when measured again and again. The set of observations will scatter about the mean. The scatter of these measurements is designated as σ , the standard deviation. It is used as an index of precision. The less the scattering more precise is the instrument. Thus, lower, the value of σ , the more precise is the instrument.

1.4.6 Accuracy

Accuracy is the degree to which the measured value of the quality characteristic agrees with the true value. The difference between the true value and the measured value is known as error of measurement. It is practically difficult to measure exactly the true value and therefore a set of observations is made whose mean value is taken as the true value of the quality measured.

1.4.7 Distinction between Precision and Accuracy

Accuracy is very often confused with precision though much different. The distinction between the precision and accuracy will become clear by the following example. Several measurements are made on a component by different types of instruments (A, B and C respectively) and the results are plotted. In any set of measurements, the individual measurements are scattered about the mean, and the precision signifies how well the various measurements

performed by same instrument on the same quality characteristic agree with each other. The difference between the mean of set of readings on the same quality characteristic and the true value is called as error. Less the error more accurate is the instrument. Figure shows that the instrument A is precise since the results of number of measurements are close to the average value. However, there is a large difference (error) between the true value and the average value hence it is not accurate. The readings taken by the instruments are scattered much from the average value and hence it is not precise but accurate as there is a small difference between the average value and true value.

1.4.8 Factors affecting the accuracy of the Measuring System

The basic components of an accuracy evaluation are the five elements of a measuring system such as:

- Factors affecting the calibration standards.
 - Factors affecting the work piece.
 - Factors affecting the inherent characteristics of the instrument.
-
-

- Factors affecting the person, who carries out the measurements,
- Factors affecting the environment.

1. **Factors affecting the Standard:** It may be affected by:

- Coefficient of thermal expansion
- Calibration interval
- Stability with time
- Elastic properties
- Geometric compatibility

2. **Factors affecting the Work piece:** These are:

- Cleanliness
- Surface finish, waviness, scratch, surface defects etc.,
- Hidden geometry
- Elastic properties,-adequate datum on the work piece
- Arrangement of supporting work piece
- Thermal equalization etc.

3. **Factors affecting the inherent characteristics of Instrument:**

- Adequate amplification for accuracy objective
- Scale error
- Effect of friction, backlash, hysteresis, zero drift error
- Deformation in handling or use, when heavy work pieces are measured
- Calibration errors
- Mechanical parts (slides, guide ways or moving elements)
- Repeatability and readability
- Contact geometry for both work piece and standard.

4. **Factors affecting person:**

- Training, skill
- Sense of precision appreciation
- Ability to select measuring instruments and standards
- Sensible appreciation of measuring cost
- Attitude towards personal accuracy achievements
- Planning measurement techniques for minimum cost, consistent with precision requirements etc.

5. Factors affecting Environment:

- Temperature, humidity etc.
- Clean surrounding and minimum vibration enhance precision
- Adequate illumination
- Temperature equalization between standard, work piece, and instrument
- Thermal expansion effects due to heat radiation from lights -Heating elements, sunlight and people
- Manual handling may also introduce thermal expansion.

Higher accuracy can be achieved only if, all the sources of error due to the above five elements in the measuring system are analyzed and steps taken to eliminate them. The above analysis of five basic metrology elements can be composed into the acronym SWIPE, for convenient reference where,

S – STANDARD W – WORKPIECE I – INSTRUMENT P – PERSON
E – ENVIRONMENT

1.5 SENSITIVITY

Sensitivity may be defined as the rate of displacement of the indicating device of an instrument, with respect to the measured quantity. In other words, sensitivity of an instrument is the ratio of the scale spacing to the scale division value. For example, if on a dial indicator, the scale spacing is 1.0 mm and the scale division value is 0.01 mm, then

sensitivity is 100. It is also called as amplification factor or gearing ratio. If we consider sensitivity over the full range of instrument reading with respect to measured quantities as shown in Figure the sensitivity at any value of $y = dx/dy$, where dx and dy are increments of x and y , taken over the full instrument scale, the sensitivity is the slope of the curve at any value of y .

The sensitivity may be constant or variable along the scale. In the first case we get linear transmission and in the second non-linear transmission. Sensitivity refers to the ability of measuring device to detect small differences in a quantity being measured. High sensitivity instruments

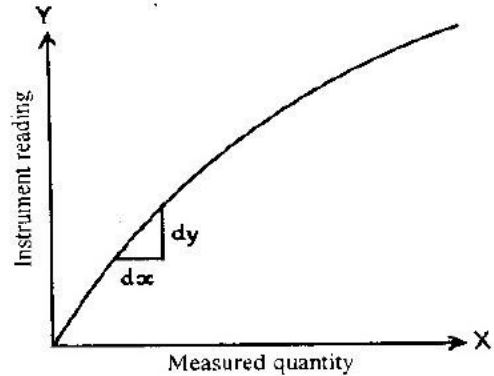

Fig 1.2 Sensitivity of Measurement

may lead to drifts due to thermal or other effects, and indications may be less repeatable or less precise than that of the instrument of lower sensitivity.

1.5.1 Readability

Readability refers to the ease with which the readings of a measuring Instrument can be read. It is the susceptibility of a measuring device to have its indications converted into meaningful number. Fine and widely spaced graduation lines ordinarily improve the readability. If the graduation lines are very finely spaced, the scale will be more readable by using the microscope; however, with the naked eye the readability will be poor. To make micrometers more readable they are provided with vernier scale. It can also be improved by using magnifying devices.

1.5.2 Calibration

The calibration of any measuring instrument is necessary to measure the quantity in terms of standard unit. It is the process of framing the scale of the instrument by applying some standardized signals. Calibration is a pre-measurement process, generally carried out by manufacturers. It is carried out by making adjustments such that the read out device produces zero output for zero measured input. Similarly, it should display an output equivalent to the known measured input near the full scale input value. The accuracy of the instrument depends upon the calibration. Constant use of instruments affects their accuracy. If the accuracy is to be maintained, the instruments must be checked and recalibrated if necessary. The schedule of such calibration depends upon the severity of use, environmental conditions, accuracy of measurement required etc. As far as possible calibration should be performed under environmental conditions which are very close to the conditions under which actual measurements are carried out. If the output of a measuring system is linear and repeatable, it can be easily calibrated.

1.5.3 Repeatability

It is the ability of the measuring instrument to repeat the same results for the measurements for the same quantity, when the measurement are carried out-by the same observer,-with the same instrument,-under the same conditions,-without any change in location,-without change in the method of measurement-and the measurements are carried out in short intervals of time. It may be expressed quantitatively in terms of dispersion of the results.

1.5.4 Reproducibility

Reproducibility is the consistency of pattern of variation in measurement i.e. closeness of the agreement between the results of measurements of the same quantity, when individual measurements are carried out:

- by different observers
- by different methods
- using different instruments
- under different conditions, locations, times etc.

1.6 STATIC AND DYNAMIC RESPONSE

The static characteristics of measuring instruments are concerned only with the steady-state reading that the instrument settles down to, such as a function of the reading.

The dynamic characteristics of a measuring instrument describe its behavior between the time a measured quantity changes value and the time when the instrument output attains a steady value in response. As with static characteristics, any values for dynamic characteristics quoted in instrument data sheets only apply when the instrument is used under specified environmental conditions. Outside these calibration conditions, some variation in the dynamic parameters can be expected.

In any linear, time-invariant measuring system, the following general relation can be written between input and output for time $(t) > 0$:

$$a_n \frac{d^n q_o}{dt^n} + a_{n-1} \frac{d^{n-1} q_o}{dt^{n-1}} + \dots + a_1 \frac{dq_o}{dt} + a_0 q_o = b_m \frac{d^m q_i}{dt^m} + b_{m-1} \frac{d^{m-1} q_i}{dt^{m-1}} + \dots + b_1 \frac{dq_i}{dt} + b_0 q_i, \quad (1)$$

where q_i is the measured quantity, q_o is the output reading, and $a_0 \dots a_n$, $b_0 \dots b_m$ are constants. If we limit consideration to that of step changes in the measured quantity only, then Equation (2) reduces to

$$a_n \frac{d^n q_o}{dt^n} + a_{n-1} \frac{d^{n-1} q_o}{dt^{n-1}} + \dots + a_1 \frac{dq_o}{dt} + a_0 q_o = b_0 q_i. \quad (2)$$

1.6.1 Zero-Order Instrument

$$a_0 q_o = b_0 q_i \quad \text{or} \quad q_o = b_0 q_i / a_0 = K q_i, \quad (3)$$

If all the coefficients $a_1 \dots a_n$ other than a_0 in Equation (2) are assumed zero, then where K is a constant known as the instrument sensitivity as defined earlier. Any instrument that behaves according to Equation (3) is said to be of a zero-order type. Following a step change in the measured quantity at time t , the instrument output moves immediately to a new value at the same time t , as shown in Figure. A potentiometer,

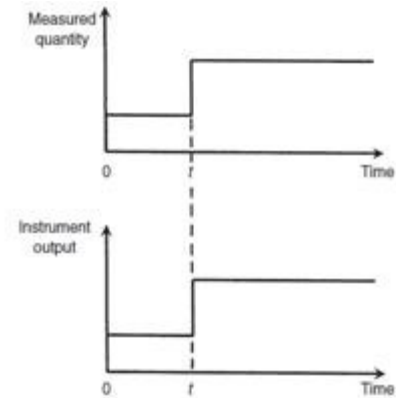

Fig 1.3 Zero Order Instrument

which measures motion is a good example of such an instrument, where the output voltage changes instantaneously as the slider is displaced along the potentiometer track.

1.6.2 First-Order Instrument

If all the coefficients $a_2 \dots a_n$ except for a_0 and a_1 are assumed zero in Equation

$$(2) \text{ then } a_1 \frac{dq_o}{dt} + a_0 q_o = b_0 q_i. \quad (3)$$

Any instrument that behaves according to Equation (4) is known as a first-order instrument. If d/dt is replaced by the D operator in Equation (4), we get

$$a_1 D q_o + a_0 q_o = b_0 q_i \quad (4)$$

$$q_o = \frac{(b_0/a_0)q_i}{[1 + (a_1/a_0)D]} \quad (5)$$

Defining $K = b_0/a_0$ as the static sensitivity and $t = a_1/a_0$ as the time constant of the system,

Equation (5) becomes (6)

1.6.3 Second-Order Instrument

If all coefficients $a_3 \dots$ other than a_0 , a_1 , and a_2 in Equation (2) are assumed zero, then we get

$$a_2 \frac{d^2 q_o}{dt^2} + a_1 \frac{dq_o}{dt} + a_0 q_o = b_0 q_i$$

$$a_2 D^2 q_o + a_1 D q_o + a_0 q_o = b_0 q_i$$

$$q_o = \frac{b_0 q_i}{a_0 + a_1 D + a_2 D^2} \quad (7)$$

$$K = b_0/a_0 \quad ; \quad \omega = \sqrt{a_0/a_2} \quad ; \quad \xi = a_1/2\sqrt{a_0 a_2}$$

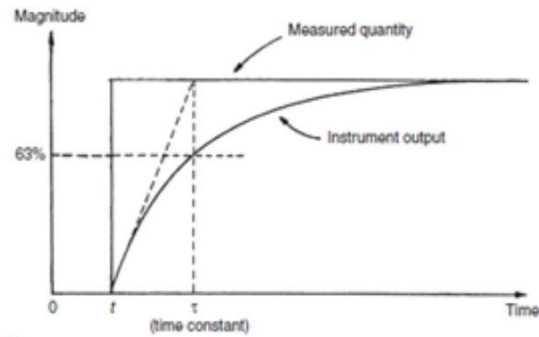

Fig 1.4 Second Order

$$\xi = \frac{a_1}{2a_0\sqrt{a_2/a_0}} = \frac{a_1\omega}{2a_0} \quad (8)$$

$$q_o = \frac{(b_0/a_0)q_i}{1 + (a_1/a_0)D + (a_2/a_0)D^2} \quad (9)$$

$$\parallel$$

$$\frac{b_0}{a_0} = K \quad ; \quad \left(\frac{a_1}{a_0}\right)D = \frac{2\xi D}{\omega} \quad ; \quad \left(\frac{a_2}{a_0}\right)D^2 = \frac{D^2}{\omega^2}$$

$$\frac{q_o}{q_i} = \frac{K}{D^2/\omega^2 + 2\xi D/\omega + 1}$$

This is the standard equation for a second-order system, and any instrument whose response can be described by it is known as a second-order instrument. If Equation (9) is solved analytically, the shape of the step response obtained depends on the value of the damping ratio parameter ξ . The output responses of a second-order instrument for

various values of ζ following a step change in the value of the measured quantity at time t are shown in Figure. Commercial second-order instruments, of which the accelerometer is a common example, are generally designed to have a damping ratio (ζ) somewhere in the range of 0.6–0.8.

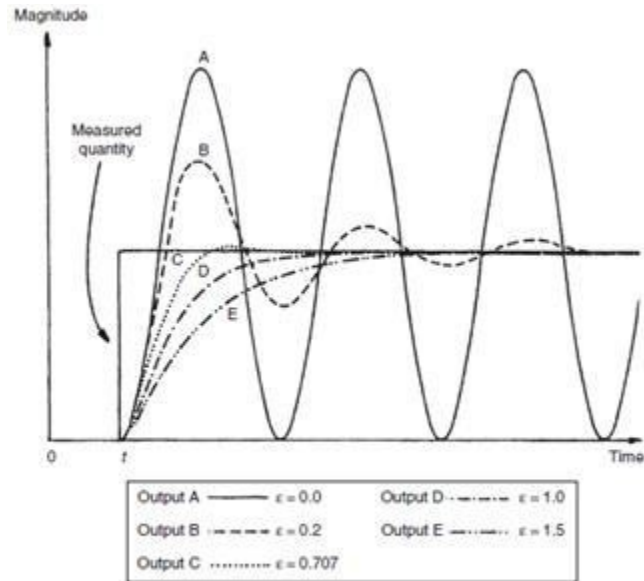

Fig 1.5 Second Order Response

1.7 ERRORS IN MEASUREMENTS

It is never possible to measure the true value of a dimension there is always some error. The error in measurement is the difference between the measured value and the true value of the measured dimension.

$$\text{Error in measurement} = \text{Measured value} - \text{True value}$$

The error in measurement may be expressed or evaluated either as an absolute error or as a relative error.

1.7.1 Absolute Error

True absolute error:

It is the algebraic difference between the result of measurement and the conventional true value of the quantity measured.

Apparent absolute error:

If the series of measurement are made then the algebraic difference between one of the results of measurement and the ar thmet al mean is known as apparent absolute error.

Relative Error:

It is the quotient of the absolute error a d the value of comparison use or calculation of that absolute error. This v lue of comparison may be the true value, the conventional true value or the arithmetic me n for series of measurement. The accuracy of measurement, and ence t e error depends upon so many factors, such as:

- calibration standard
- Work piece
- Instrument
- Person
- Environ ent etc

1.7.2 Types of Errors

1. Systematic Error

These errors include calibration errors, error due to variation in the atmospheric condition Variation in contact pressure etc. If properly analyzed, these errors can be determined and reduced or even eliminated hence also called controllable errors. All other systematic errors can be controlled in magnitude and sense except personal error.

These errors result from irregular procedure that is consistent in action. These errors are repetitive in nature and are of constant and similar form.

2. Random Error

These errors are caused due to variation in position of setting standard and work-piece errors. Due to displacement of level joints of instruments, due to backlash and friction, these errors are induced. Specific cause, magnitude and sense of these errors cannot be determined from the knowledge of measuring system or condition of measurement. These errors are non-consistent and hence the name random errors.

3. Environmental Error

These errors are caused due to effect of surrounding temperature, pressure and humidity on the measuring instrument. External factors like nuclear radiation, vibrations and magnetic field also lead to error. Temperature plays an important role where high precision is required. e.g. while using slip gauges, due to handling the slip gauges may acquire human body temperature, whereas the work is at 20°C. A 300 mm length will go in error by 5 microns which is quite a considerable error. To avoid errors of this kind, all metrology laboratories and standard rooms worldwide are maintained at 20°C.

1.7.3 Calibration

It is very much essential to calibrate the instrument so as to maintain its accuracy. In case when the measuring and the sensing system are different it is very difficult to calibrate the system as a whole, so in that case we have to take into account the error producing properties of each component. Calibration is usually carried out by making adjustment such that when the instrument is having zero measured input then it should read out zero and when the instrument is measuring some dimension it should read it to

Calibration is the process of checking the dimension and tolerances of a gauge, or the accuracy of a measurement instrument by comparing it to the instrument/gauge that has been certified as a standard of known accuracy. Calibration of an instrument is done over a period of time, which is decided depending upon the usage of the instrument or on the materials of the parts from which it is made. The dimensions and the tolerances of the instrument/gauge are checked so that we can come to whether the instrument can be used again by calibrating it or is it wear out or deteriorated above the limit value. If it is so then it is thrown out or it is scrapped. If the gauge or the instrument is frequently used, then it will require more maintenance and frequent calibration. Calibration of instrument is done prior to its use and afterwards to verify that it is within the tolerance limit or not. Certification is given by making comparison between the instrument/gauge with the reference standard whose calibration is traceable to accepted National standard.

1.8 INTRODUCTION TO DIMENSIONAL AND GEOMETRIC TOLERANCE

1.8.1 General Aspects

In the design and manufacture of engineering products a great deal of attention has to be paid to the mating, assembly and fitting of various components. In the early days of mechanical engineering during the nineteenth century, the majority of such components were actually mated together, their dimensions being adjusted until the required type of fit was obtained. These methods demanded craftsmanship of a high order and a great deal of very fine work was produced. Present day standards of quantity production, interchangeability, and continuous assembly of many complex compounds, could not exist under such a system, neither could many of the exacting design requirements of modern machines be fulfilled without the knowledge that certain dimensions can be reproduced with precision on any number of components. Modern mechanical production engineering is based on a system of limits and fits, which while not only itself ensuring the necessary accuracies of manufacture, forms a schedule or specifications to which manufacturers can adhere.

In order that a system of limits and fits may be successful, following conditions must be fulfilled:

1. The range of sizes covered by the system must be sufficient for most purposes
2. It must be based on some standards; so that everybody understands alike and a given dimension has the same meaning at all places.
3. For any basic size it must be possible to select from a carefully designed range of fit the most suitable one for a given application.
4. Each basic size of hole and shaft must have a range of tolerance values for each of the different fits.
5. The system must provide for both unilateral and bilateral methods of applying the tolerance.
6. It must be possible for a manufacturer to use the system to apply either a hole-based or a shaft-based system as his manufacturing requirements may need.
7. The system should cover work from high class tool and gauge work where very wide limits of sizes are permissible.

1.8.2 Nominal Size and Basic Dimensions

Nominal size: A 'nominal size' is the size which is used for purpose of general identification. Thus the nominal size of a hole and shaft assembly is 60 mm, even though the basic size of the hole may be 60 mm and the basic size of the shaft 59.5 mm.

Basic dimension: A 'basic dimension' is the dimension, as worked out by purely design considerations. Since the ideal conditions of producing basic dimension, do not exist, the basic dimensions can be treated as the theoretical or nominal size, and it has only to be approximated. A study of function of machine part would reveal that it is unnecessary to attain perfection because some variations in dimension, however small, can be tolerated size of various parts. It is, thus, general practice to specify a basic dimension and indicate by tolerances as to how much variation in the basic dimension

can be tolerated without affecting the functioning of the assembly into which this part will be used.

1.8.3 Definitions

The definitions given below are based on those given in IS: 919

Shaft: The term shaft refers not only to diameter of a circular shaft to any external dimension on a component.

Hole: This term refers not only to the diameter of a circular hole but to any internal dimension on a component.

Basics of Fit

A fit or limit system consists of a series of tolerances arranged to suit a specific range of sizes and functions, so that limits of size may be selected and given to mating components to ensure specific classes of fit. This system may be arranged on the following basis:

1. Hole basis system
2. Shaft basis system.

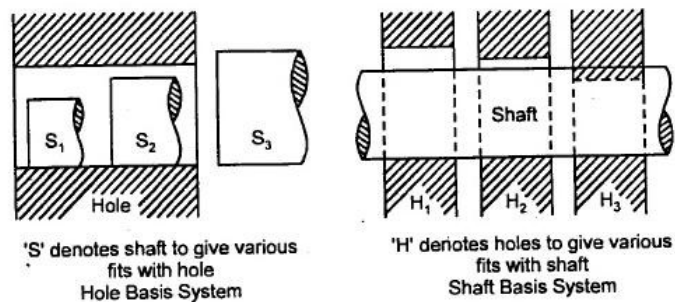

Fig 1.6 Nominal & Basic Dimension

Hole basis system:

'Hole basis system' is one in which the limits on the hole are kept constant and the variations necessary to obtain the classes of fit are arranged by varying those on the shaft.

Shaft basis system:

'Shaft basis system' is one in which the limits on the shaft are kept constant and the variations necessary to obtain the classes of fit are arranged by varying the limits on

the holes. In present day industrial practice hole basis system is used because a great many holes are produced by standard tooling, for example, reamers drills, etc., whose size is not adjustable. Subsequently the shaft sizes are more readily variable about the basic size by means of turning or grinding operations. Thus the hole basis system results in considerable reduction in reamers and other precision tools as compared to a shaft basis system because in shaft basis system due to non-adjustable nature of reamers, drills etc. great variety (of sizes) of these tools are required for producing different classes of holes for one class of shaft for obtaining different fits.

1.8.4 Systems of Specifying Tolerances

The tolerance or the error permitted in manufacturing a particular dimension may be allowed to vary either on one side of the basic size or on either side of the basic size. Accordingly two systems of specifying tolerances exist.

1. Unilateral system
2. Bilateral system.

Examples: $+0.04$ or -0.02
 40.0 or 40.0
 $+0.02$ or -0.04

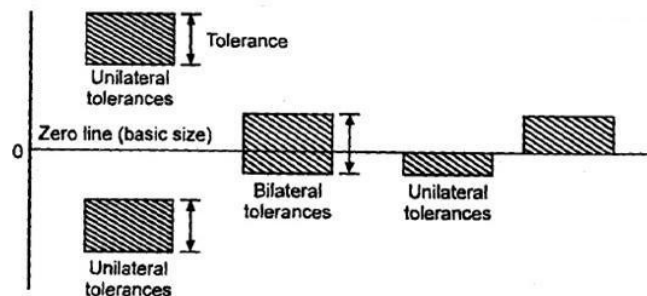

Fig 1.7 Types of Tolerances

In the bilateral system of writing tolerances, a dimension is permitted to vary in two directions.

+ 0.02
Examples: 40.0
- 0.04

1.9 INTERCHANGEABILITY

It is the principle employed to mating parts or components. The parts are picked at random, complying with the stipulated specifications and functional requirements of the assembly. When only a few assemblies are to be made, the correct fits between parts are made by controlling the sizes while machining the parts, by matching them with their mating parts. The actual sizes of the parts may vary from assembly to assembly to such an extent that a given part can fit only in its own assembly. Such a method of manufacture takes more time and will therefore increase the cost. There will also be problems when parts are needed to be replaced. Modern production is based on the concept of interchangeability. When one component assembles properly with any mating component, both being chosen at random, then it is interchangeable manufacture. It is the uniformity of size of the components produced which ensures interchangeability.

1.9.1 The advantages of interchangeability are as follows:

1. The assembly of mating parts is easier. Since any component picked up from its lot will assemble with any other mating part from another lot without additional fitting and machining.
 2. It enhances the production rate.
 3. The standardization of machine parts and manufacturing methods is decided.
 4. It brings down the assembling cost drastically.
 5. Repairing of existing machines or products is simplified because component parts can be easily replaced.
 6. Replacement of worn out parts is easy.
-

QUESTION BANK

PART – A (2 MARKS)

1. Differentiate between sensitivity and range with suitable example.
2. Define system error and correction.
3. Define: Measurand.
4. Define: Deterministic Metrology.
5. Define over damped and under damped system.
6. Give any four methods of measurement
7. Give classification of measuring instruments.
8. Define True size
9. Define Actual size
10. What is Hysteresis
11. What is Range of measurement?
13. Define Span
14. What is Resolution?

PART – B (16 MARKS)

1. Draw the block diagram of generalized measurement system and explain different stages with examples.
2. Distinguish between Repeatability and reproducibility
3. Distinguish between Systematic and random errors
4. Distinguish between Static and dynamic response.
5. Describe the different types of errors in measurements and the causes.
6. List the various measurement methods and explain
7. Briefly discuss on the applications of measuring instruments
8. Briefly discuss on calibration of temperature measuring devices with suitable examples
9. Explain the various systematic and random errors in measurements?
10. What is the need of calibration? Explain the classification of various measuring methods.

11. Describe loading errors and environmental errors.
12. What are elements of a measuring system? How they affect accuracy and precision?
How error due to these elements are eliminated



MODULE II

LINEAR AND ANGULAR MEASUREMENTS



CONTENTS

- 2.1 LINEAR MEASURING INSTRUMENTS
 - 2.1.1 SCALES
 - 2.1.2 CALIPERS
 - 2.1.3 VERNIER CALIPERS
 - 2.1.4 MICROMETERS
 - 2.1.5 SLIP GAUGES
 - 2.2 INTERFEROMETERS
 - 2.3 LIMIT GAUGES
 - 2.4 PLUG GAUGES
 - 2.5 TAPER PLUG GAUGE
 - 2.6 RING GAUGES
 - 2.7 SNAP GAUGE
 - 2.8 TAYLOR' S PRINCIPLE
 - 2.9 COMPARATORS
 - 2.9.1 MECHANICAL COMPARATORS
 - 2.9.2 ELECTRICAL COMPARATOR
 - 2.9.3 ELECTRONIC COMPARATOR
 - 2.10 SINE BAR
 - 2.11 BEVEL PROTRACTORS
 - 2.11.1 VERNIER BEVEL PROTRACTOR:
 - 2.12 AUTO- COLLIMATOR
 - 2.12.1 WORKING OF AUTO-COLLIMATOR
 - 2.12.2 APPLICATIONS OF AUTO-COLLIMATOR
 - 2.13 ANGLE DEKKOR
-

TECHNICAL TERMS

▮ **Comparators**

Comparators are one form of linear measurement device which is quick and more convenient for checking large number of identical dimensions.

▮ **Least count**

The least value that can be measured by using any measuring instrument known as least count. Least count of a mechanical comparator is 0.01 mm.

▮ **Caliper**

Caliper is an instrument used for measuring distance between or over surfaces comparing dimensions of work pieces with such standards as plug gauges, graduated rules etc.

▮ **Interferometer**

They are optical instruments used for measuring flatness and determining the length of the slip gauges by direct reference to the wavelength of light.

▮ **Sine bar**

Sine bars are always used along with slip gauges as a device for the measurement of angles very precisely

▮ **Auto-collimator**

Auto-collimator is an optical instrument used for the measurement of small angular differences, changes or deflection, plane surface inspection etc.

2.1 LINEAR MEASURING INSTRUMENTS

Linear measurement applies to measurement of lengths, diameter, heights and thickness including external and internal measurements. The linear measuring instruments have series of accurately spaced lines marked on them e.g. Scale. The dimensions to be measured are aligned with the graduations of the scale. Linear measuring instruments are designed either for line measurements or end measurements. In end measuring instruments, the measurement is taken between two end surfaces in micrometers, slip gauges etc.

The instruments used for linear measurements can be classified as:

1. Direct measuring instruments
2. Indirect measuring instruments

1. Graduated
2. Non Graduated

The graduated instruments include rules, vernier calipers, vernier height gauges, vernier depth gauges, micrometers, dial indicators etc.

The non graduated instruments include calipers, trammels, telescopic gauges, surface gauges, straight edges, wire gauges, screw pitch gauges, radius gauges, thickness gauges, slip gauges etc. They can also be classified as

1. Non precision instruments such as steel rule, calipers etc.,
2. Precision measuring instruments, such as vernier instruments, micrometers, dial gauges etc.

2.1.1 SCALES

- The most common tool for crude measurements is the scale (also known as **rules, or rulers**).
 - Although plastic, wood and other materials are used for common scales, precision scales use tempered steel alloys, with graduations scribed onto the surface.
-
-

- These are limited by the human eye. Basically they are used to compare two dimensions.
- The metric scales use decimal divisions, and the imperial scales use fractional divisions.
- Some scales only use the fine scale divisions at one end of the scale. It is advised that the end of the scale not be used for measurement. This is because as they become worn with use, the end of the scale will no longer be at a 'zero' position.
- Instead the internal divisions of the scale should be used. Parallax error can be a factor when making measurements with a scale.

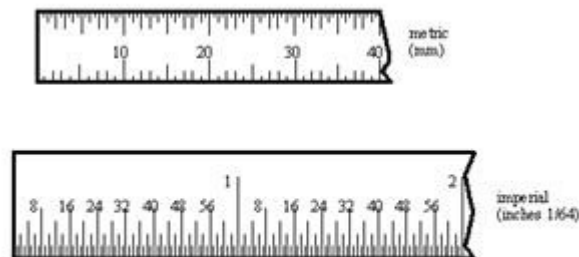

Fig 2.1 Scale

2.1.2 CALIPERS

Caliper is an instrument used for measuring distance between or over surfaces comparing dimensions of work pieces with such standards as plug gauges, graduated rules etc. Calipers may be difficult to use, and they require that the operator follow a few basic rules, do not force them, they will bend easily, and invalidate measurements made. If measurements are made using calipers for comparison, one operator should make all of the measurements (this keeps the feel factor a minimal error source). These instruments are very useful when dealing with hard to reach locations that normal measuring instruments cannot reach. Obviously the added step in the measurement will significantly decrease the accuracy.

2.1.3 VERNIER CALIPERS

The vernier instruments generally used in workshop and engineering metrology have comparatively low accuracy. The line of measurement of such instruments does not coincide with the line of scale. The accuracy therefore depends upon the straightness of the beam and the squareness of the sliding jaw with respect to the beam. To ensure the squareness, the sliding jaw must be clamped before taking the reading. The zero error must also be taken into consideration. Instruments are now available with measuring range up to one meter with a scale value of 0.1 or 0.2 mm.

Types of Vernier Calipers

According to Indian Standard IS: 3651-1974, three types of vernier calipers have been specified to make external and internal measurements and are shown in figures respectively. All the three types are made with one scale on the front of the beam for direct reading.

Type A: Vernier has jaws on both sides for external and internal measurements and a blade for depth measurement.

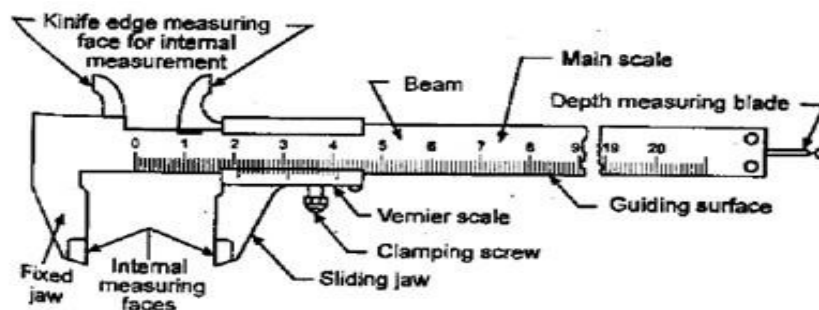

Fig 2.2 Vernier Caliper - Type A

Type B: It is provided with jaws on one side for external and internal measurements.

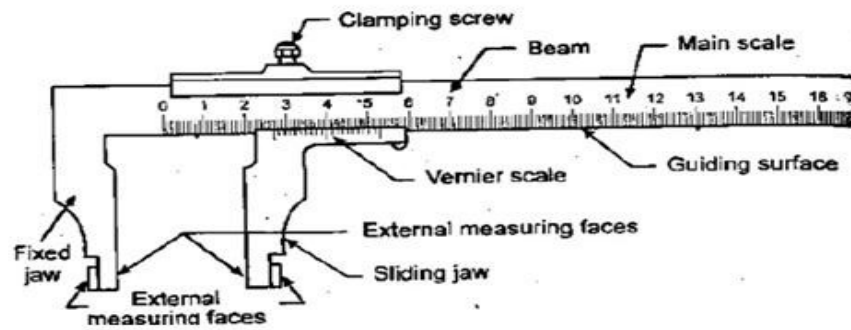

Fig 2.3 Vernier Caliper - Type B

Type C: It has jaws on both sides for making the measurement and for marking operations.

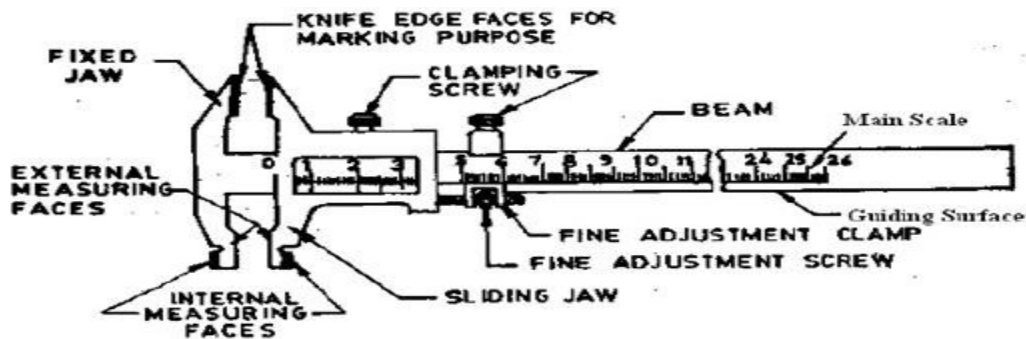

Fig 2.4 Vernier Caliper - Type C

Errors in Calipers

The degree of accuracy obtained in measurement greatly depends upon the condition of the jaws of the calipers and a special attention is needed before proceeding for the measurement. The accuracy and natural wear, and warping of Vernier caliper jaws should be tested frequently by closing them together tightly and setting them to 0-0 point of the main and Vernier scales.

2.1.4 MICROMETERS

There are two types in it.

- (i) Outside micrometer — To measure external dimensions.
- (ii) Inside micrometer — To measure internal dimensions.

An outside micrometer is shown. It consists of two scales, main scale and thimble scale. While the pitch of barrel screw is 0.5 mm the thimble has graduation of 0.01 mm. The **least count** of this micrometer is 0.01 mm.

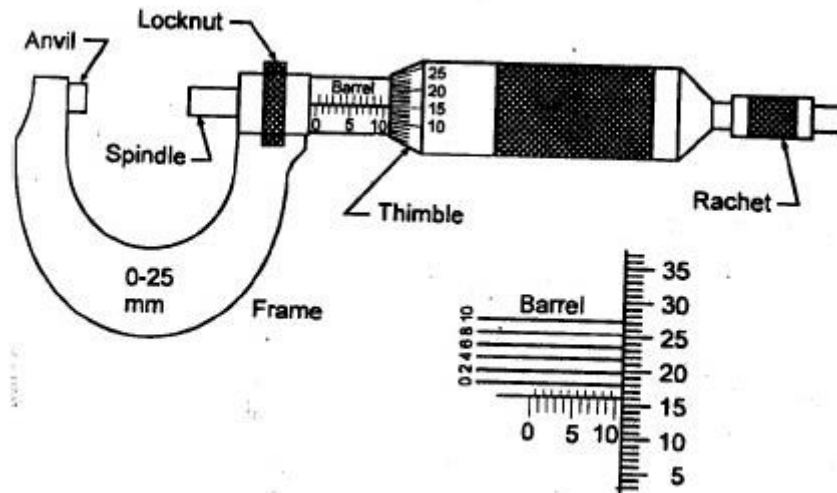

Fig 2.5 Micrometer

The micrometer requires the use of an accurate screw thread as a means of obtaining a measurement. The screw is attached to a spindle and is turned by movement of a thimble or ratchet at the end. The barrel, which is attached to the frame, acts as a nut to engage the screw threads, which are accurately made with a pitch of 0.05mm. Each revolution of the thimble advances the screw 0.05 mm. On the barrel a datum line is graduated with two sets of division marks.

2.1.5 SLIP GAUGES

These may be used as reference standards for transferring the dimension of the unit of length from the primary standard to gauge blocks of lower accuracy and for the verification and graduation of measuring apparatus. These are high carbon steel hardened, ground and lapped rectangular blocks, having cross sectional area of 30 mm

10mm. Their opposite faces are flat, parallel and are accurately the stated distance apart. The opposite faces are of such a high degree of surface finish, that when the blocks are pressed together with a slight twist by hand, they will wring together. They will remain firmly attached to each other. They are supplied in sets of 112 pieces down to 32 pieces. Due to properties of slip gauges, they are built up by, wringing into combination which gives size, varying by steps of 0.01 mm and the overall accuracy is of the order of 0.00025mm. Slip gauges with three basic forms are commonly found, these are rectangular, square with center hole, and square without center hole.

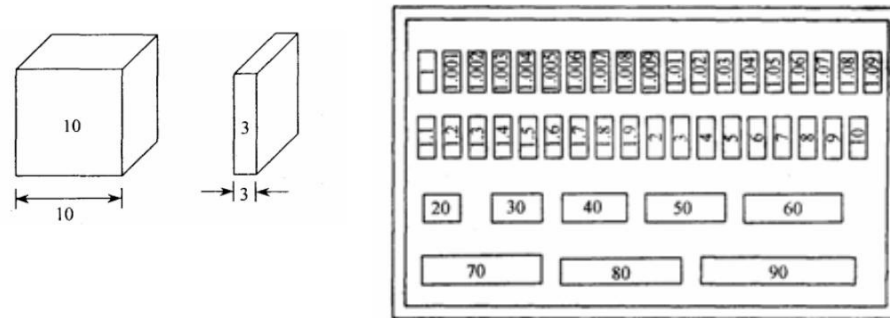

Fig 2.6 Slip Gauge

Wringing or Sliding is nothing but combining the faces of slip gauges one over the other. Due to adhesion property of slip gauges, they will stick together. This is because of very high degree of surface finish of the measuring faces.

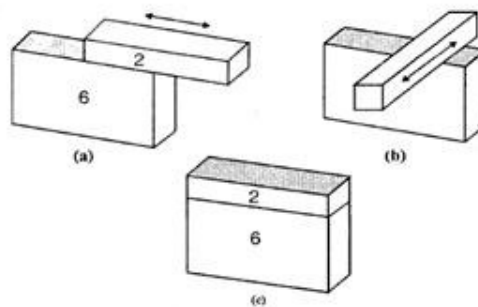

Fig 2.7 Wringing of slip gauge

Classification of Slip Gauges

Slip gauges are classified into various types according to their use as follows:

- 1) Grade 2
- 2) Grade 1
- 3) Grade 0
- 4) Grade 00
- 5) Calibration grade.

1) Grade 2:

It is a workshop grade slip gauges used for setting tools, utters and checking dimensions roughly.

2) Grade 1:

The grade I is used for precise work in tool rooms.

3) Grade 0:

It is used as inspection grade of slip gauges mainly by inspection department.

4) Grade 00:

Grade 00 mainly used in high precision works in the form of error detection in instruments.

5) Calibration grade:

The actual size of the slip gauge is calibrated on a chart supplied by the manufactures.

Manufacture of Slip Gauges

The following additional operations are carried out to obtain the necessary qualities in slip gauges during manufacture.

- i. First the approximate size of slip gauges is done by preliminary operations.
 - ii. The blocks are hardened and wear resistant by a special heat treatment process.
 - iii. To stabilize the whole life of blocks, seasoning process is done.
 - iv. The approximate required dimension is done by a final grinding process.
-

- v. To get the exact size of slip gauges, lapping operation is done.
- vi. Comparison is made with grand master sets.

Slip Gauges accessories

The application slip gauges can be increased by providing accessories to the slip gauges. The various accessories are

- Measuring jaw
- Scriber and Centre point.
- Holder and base

1. Measuring jaw:

It is available in two designs specially made for internal and external features.

2. Scriber and Centre point:

It is mainly formed for marking purpose.

3. Holder and base:

Holder is nothing but a holding device used to hold combination of slip gauges. Base is designed for mounting the holder rigidly on its top surface.

2.2 INTERFEROMETERS

They are optical instruments used for measuring flatness and determining the length of the slip gauges by direct reference to the wavelength of light. It overcomes the drawbacks of optical flats used in ordinary daylight. In these instruments the lay of the optical flat can be controlled and fringes can be oriented as per the requirement. An arrangement is made to view the fringes directly from the top and avoid any distortion due to incorrect viewing.

2.2.1 Optical Flat and Calibration

1. Optical flats are flat lenses, made from quartz, having a very accurate surface to transmit light.
2. They are used in interferometers, for testing plane surfaces.
3. The diameter of an optical flat varies from 50 to 250 mm and thickness varies from 12 to 25 mm.
4. Optical flats are made in a range of sizes and shapes.
5. The flats are available with a coated surface.
6. The coating is a thin film, usually titanium oxide, applied on the surface to reduce the light lost by reflection.
7. The coating is so thin that it does not affect the position of the fringe bands, but a coated flat. The supporting surface on which the optical flat measurements are made must provide a clean, rigid platform. Optical flats are cylindrical in form, with the working surface and are of two types are i) type A, ii) type B.

i) Type A:

It has only one surface flat and is used for testing flatness of precision measuring surfaces of flats, slip gauges and measuring tables. The tolerance on flat should be $0.05 \mu\text{m}$ for type A.

ii) Type B:

It has both surfaces flat and parallel to each other. They are used for testing measuring surfaces of microeters, Measuring anvils and similar length of measuring devices for testing flatness and parallelism. For these instruments, their thickness and grades are important. The tolerances on flatness, parallelism and thickness should be $0.05 \mu\text{m}$.

2.2.2 Interference Bands by Optical Flat

Optical flats are blocks of glass finished to within 0.05 microns for flatness. When an optical flat is on a flat surface which is not perfectly flat, then the optical flat will not exactly coincide with it, but it will make an angle e with the surface as shown in Figure 2.8.

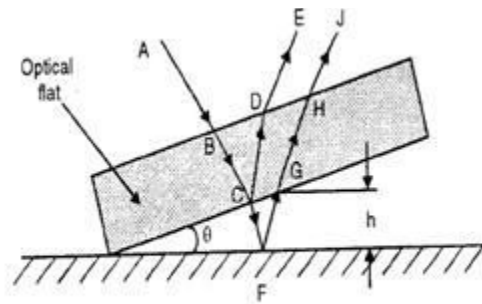

Fig 2.8 Optical Flat

2.3 LIMIT GAUGES

- A limit gauge is not a measuring gauge. Just they are used as inspecting gauges.
 - The limit gauges are used in inspection by methods of attributes.
 - This gives the information about the products which may be either within the prescribed limit or not.
 - By using limit gauges report, the control charts of P and C charts are drawn to control invariance of the products.
 - This procedure is mostly performed by the quality control department of each and every industry.
 - Limit gauges are mainly used for checking for cylindrical holes of identical components with a large numbers in mass production.
-

2.3.1 Purpose of using limit gauges

- Components are manufactured as per the specified tolerance limits, upper limit and lower limit. The dimension of each component should be within this upper and lower limit.
- If the dimensions are outside these limits, the components will be rejected.
- If we use any measuring instruments to check these dimensions, the process will consume more time. Still we are not interested in knowing the amount of error in dimensions.
- It is just enough whether the size of the component is within the prescribed limits or not. For this purpose, we can make use of gauges known as limit gauges.

The common types are as follows:

- 1) Plug gauges.
- 2) Ring gauges.
- 3) Snap gauges.

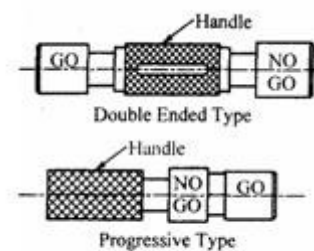

Fig 2.9 Plug Gauge

2.4 PLUG GAUGES

- The ends are hardened and accurately finished by grinding. One end is the GO end and the other end is NOGO end.
 - Usually, the GO end will be equal to the lower limit size of the hole and the NOGO end will be equal to the upper limit size of the hole.
 - If the size of the hole is within the limits, the GO end should go inside the hole and NOGO end should not go.
 - If the GO end does not go, the hole is under size and also if NOGO end goes, the hole is **over size**. Hence, the components are rejected in both the cases.
-

1. Double ended plug gauges

In this type, the GO end and NOGO end are arranged on both the ends of the plug. This type has the advantage of easy handling.

2. Progressive type of plug gauges

In this type both the GO end and NOGO end are arranged in the same side of the plug. We can use the plug gauge ends progressively one after the other while checking the hole. It saves time. Generally, the GO end is made larger than the NOGO end in plug gauges.

2.5 TAPER PLUG GAUGE

Taper plug gauges are used to check tapered holes. It has two check lines. One is a GO line and another is a NOGO line. During the checking of work, NOGO line remains outside the hole and GO line remains inside the hole.

They are various types taper plug gauges are available as shown in fig. Such as

- 1) Taper plug gauge — plain
- 2) Taper plug gauge — tapered.
- 3) Taper ring gauge plain
- 4) Taper ring gauge — tapered.

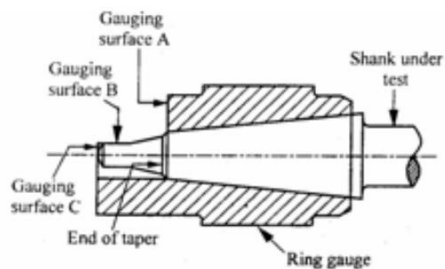

Fig 2.11 Taper ring Gauge plain

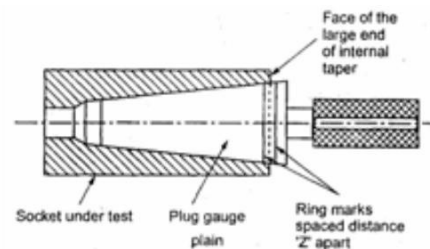

Fig 2.10 Taper Gauge

2.6 RING GAUGES

- Ring gauges are mainly used for checking the diameter of shafts having a central hole. The hole is accurately finished by grinding and lapping after taking hardening process.
- The periphery of the ring is knurled to give more grips while handling the gauges. We have to make two ring gauges separately to check the shaft such as GO ring gauge and NOGO ring gauge.
- But the hole of GO ring gauge is made to the upper limit size of the shaft and NOGO for the lower limit.
- While checking the shaft, the GO ring gauge will pass through the shaft and NOGO will not pass.
- To identify the NOGO ring gauges easily, red mark or a small groove cut on its periphery.

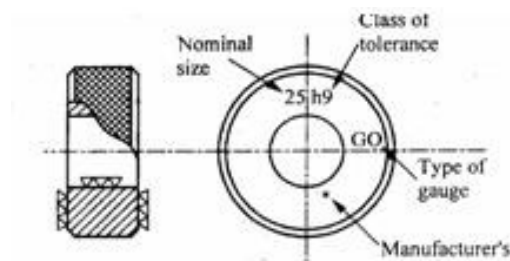

Fig 2.12 Ring Gauge

2.7 SNAP GAUGE

Snap gauges are used for checking external dimensions. They are also called as gap gauges. The different types of snap gauges are:

1. Double Ended Snap Gauge

This gauge is having two ends in the form of anvils. Here also, the GO anvil is made to lower limit and NOGO anvil is made to upper limit of the shaft. It is also known as solid snap gauges

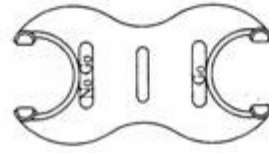

Fig 2.13 Double ended Snap Gauge

2. Progressive Snap Gauge

This type of snap gauge is also called caliper gauge. It is mainly used for checking large diameters up to 100mm. Both GO and NOGO anvils at the same end. The GO anvil should be at the front and NOGO anvil at the rear. So, the diameter of the shaft is checked progressively by these two ends. This type of gauge is made of horse shoe shaped frame with I section to reduce the weight of the snap gauges.

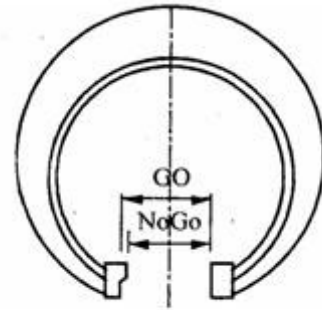

Fig 2.14 Progressive Snap Gauge

3. Adjustable Snap Gauge

Adjustable snap gauges are used for checking large size shafts and are made with a horseshoe shaped frame of I section. It has one fixed anvil and two small adjustable anvils. The distance between the two anvils is adjusted by adjusting the adjustable anvils by means of setscrews. This adjustment can be made with the help of slip gauges for specified limits of size.

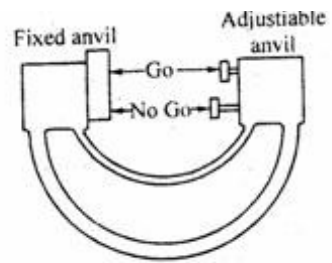

Fig 2.15 Adjustable Snap Gauge

4. Combined Limit Gauges

A spherical projection is provided with GO and NOGO dimension marked in a single gauge. While using GO gauge the handle is parallel to axes of the hole and normal to axes for NOGO gauge.

5. Position Gauge

It is designed for checking the position of features in relation to another surface. Other types of gauges are also available such as contour gauges, receiver gauges, profile gauges etc.

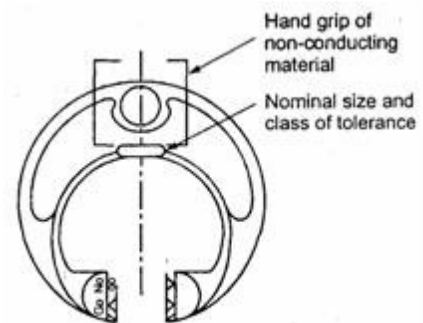

Fig 2.17 Position Gauge

2.8 TAYLOR'S PRINCIPLE

It states that GO gauge should check all related dimensions. Simultaneously NOGO gauge should check only one dimension at a time.

Maximum metal condition

It refers to the condition of hole or shaft when maximum material is left on i.e. high limit of shaft and low limit of hole.

Minimum metal condition

It refers to the condition of hole or shaft when minimum material is left on such as low limit of shaft and high limit of hole.

Applications of Limit Gauges

1. Thread gauges
2. Form gauges
3. Screw pitch gauges
4. Radius and fillet gauges
5. Feeler gauges
6. Plate gauge and Wire gauge

2.9 COMPARATORS

Comparators are one form of linear measurement device which is quick and more convenient for checking large number of identical dimensions. Comparators normally will not show the actual dimensions of the work piece. They will be shown only the deviation in size. i.e. During the measurement a comparator is able to give the deviation of the dimension from the set dimension. It cannot be used as an absolute measuring device but can only compare two dimensions. Comparators are designed in several types to meet various conditions. Comparators of every type incorporate some kind of magnifying device. The magnifying device magnifies how much dimension deviates, plus or minus, from the standard size.

The comparators are classified according to the principles used for obtaining magnification. The common types are:

- 1) Mechanical comparators
 - 2) Electrical comparators
 - 3) Optical comparators
 - 4) Pneumatic comparators
-

2.9.1 MECHANICAL COMPARATORS

Mechanical comparator employs mechanical means for magnifying small deviations. The method of magnifying small movement of the indicator in all mechanical comparators are effected by means of levers, gear trains or a combination of these elements. Mechanical comparators are available having magnifications from 300 to 5000 to 1. These are mostly used for inspection of small parts machined to close limits.

1. Dial indicator

A dial indicator or dial gauge is used as a mechanical comparator. The essential parts of the instrument are like a small clock with a plunger projecting at the bottom as shown in fig. Very slight upward movement on the plunger moves it upward and the movement is indicated by the dial pointer. The dial is graduated into 100 divisions. A full revolution of the pointer about this scale corresponds to 1mm travel of the plunger. Thus, a turn of the pointer by one scale division represents a plunger travel of 0.01mm.

Experimental setup

The whole setup consists of worktable, dial indicator and vertical post. The dial indicator is fitted to vertical post by an adjusting screw as shown in fig. The vertical post is fitted on the work table; the top surface of the worktable is finely finished. The dial gauge can be adjusted vertically and locked in position by a screw.

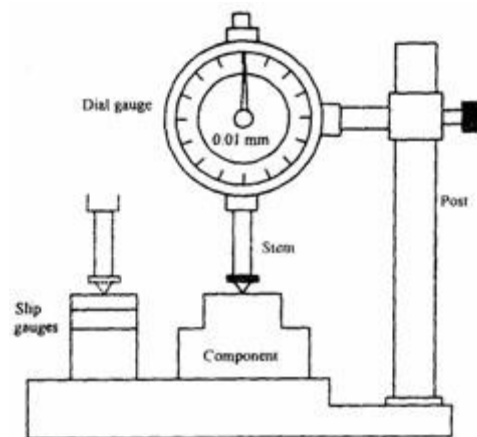

Fig 2.18 Dial Indicator

Procedure

Let us assume that the required height of the component is 32.5mm. Initially this height is built up with slip gauges. The slip gauge blocks are placed under the stem of the dial gauge. The pointer in the dial gauge is adjusted to zero. The slip gauges are removed.

Now the component to be checked is introduced under the stem of the dial gauge. If there is any deviation in the height of the component, it will be indicated by the pointer.

Mechanism

The stem has rack teeth. A set of gears engage with the rack. The pointer is connected to a small pinion. The small pinion is independently hinged. I.e. it is not connected to the stem. The vertical movement of the stem is transmitted to the pointer through a set of gears. A spring gives a constant downward pressure to the stem.

2. Read type mechanical comparator

In this type of comparator, the linear movement of the plunger is specified by means of read mechanism. The mechanism of this type is illustrated in fig. A spring-loaded pointer is pivoted. Initially, the comparator is set with the help of a known dimension e.g. Set of slip gauges as shown in fig. Then the indicator reading is adjusted to zero. When the part to be measured is kept under the pointer, then the comparator displays the deviation of this dimension either in \pm or $-$ side of the set dimension

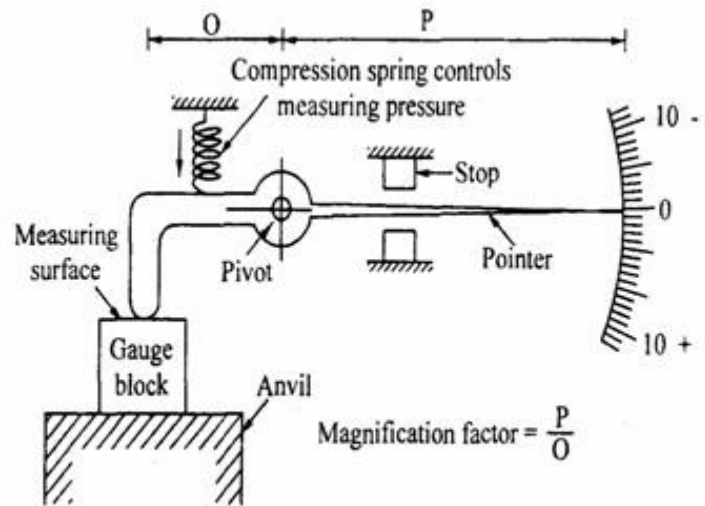

Fig 2.18 Read type Mechanical Comparator

Advantages

- 1) It is usually robust, compact and easy to handle.
- 2) There is no external supply such as electricity, air required.
- 3) It has very simple mechanism and is cheaper when compared to other types
- 4) It is suitable for ordinary workshop and also easily portable.

Disadvantages

- 1) Accuracy of the comparator mainly depends on the accuracy of the rack and pinion arrangement. Any slackness will reduce accuracy.
- 2) It has more moving parts and hence friction is more and accuracy is less.
- 3) The range of the instrument is limited since pointer is moving over a fixed scale.

2.9.2 ELECTRICAL COMPARATOR:

An electrical comparator consists of the following three major parts such as

- 1) Transducer
- 2) Display device as meter
- 3) Amplifier

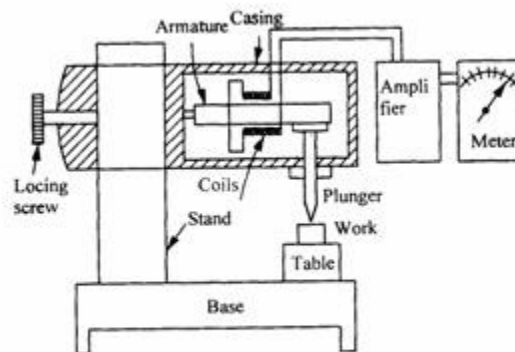

Fig 2.19 Electrical Comparator

Transducer

An iron armature is provided in between two coils held by a leaf spring at one end. The other end is supported against a plunger. The two coils act as two arms of an A.C. wheat stone bridge circuit.

Amplifier

The amplifier is nothing but a device which amplifies the given input signal frequency into magnified output.

Display device or meter

The amplified input signal is displayed on some terminal stage instruments. Here, the terminal instrument is a meter.

Working principle

If the armature is centrally located between the coils, the inductance of both coils will be equal but in opposite direction with the sign change. Due to this, the bridge circuit of A.C. wheat stone bridge is balanced. Therefore, the meter will read zero value. But practically, it is not possible. In real cases, the armature may be lifted up or lowered down by the plunger during the measurement. This would upset the balance of the wheat stone bridge circuit. Due to this effect, the change in current or potential will be induced correspondingly. On that time, the meter will indicate some value as displacement. This indicated value may be either for larger or smaller components. As this induced current is too small, it should be suitably amplified before being displayed in the meter.

Checking of accuracy

To check the accuracy of a given specimen or work, first a standard specimen is placed under the plunger. After this, the resistance of wheat stone bridge is adjusted so

that the scale reading shows zero. Then the specimen is removed. Now, the work is introduced under the plunger. If height variation of work presents, it will move the plunger up or down. The corresponding movement of the plunger is first amplified by the amplifier then it is transmitted to the meter to show the variations. The least count of this electrical comparator is **0.001mm (one micron)**.

2.9.3 ELECTRONIC COMPARATOR

In electronic comparator, transducer induction or the principle of application of frequency modulation or radio oscillation is followed.

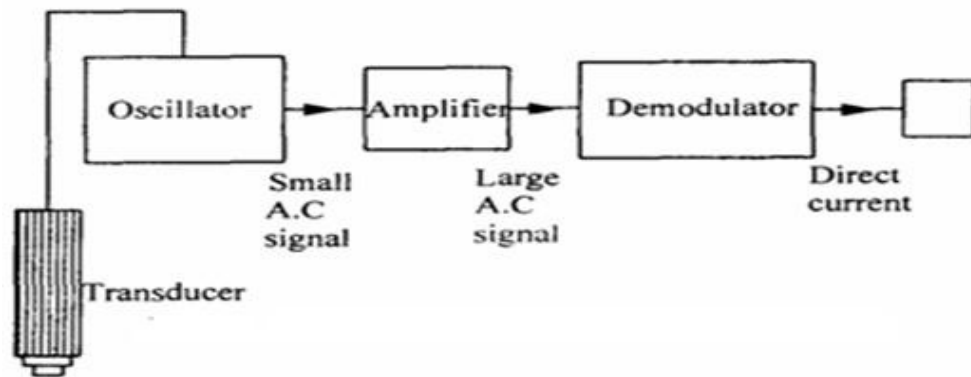

Fig 2.20 *Principle of operation in electric gauging*

Construction details

In the electronic comparator, the following components are set as follows:

- i. Transducer
- ii Oscillator
- iii Amplifier
- iv. Demodulator
- v. Meter

(i) Transducer

It converts the movement of the plunger into an electrical signal. It is connected with oscillator.

(ii) Oscillator

The oscillator which receives electrical signal from the transducer and raises the amplitude of frequency wave by adding carrier frequency called as modulation

(iii) Amplifier

An amplifier is connected in between oscillator and demodulator. The signal coming out of the oscillator is amplified into a required level.

(iv) Demodulator

Demodulator is nothing but a device which cuts off external carrier wave frequency. i.e. It converts the modulated wave into original wave as electrical signal.

(v) Meter

This is nothing but a display device from which the output can be obtained as a linear measurement.

2.9.3.1 Principle of operation

The work to be measured is placed under the plunger of the electronic comparator. Both work and comparator are made to rest on the surface plate. The linear movement of the plunger is converted into electrical signal by a suitable transducer. Then it sent to an oscillator to modulate the electrical signal by adding carrier frequency of wave. After that the amplified signal is sent to demodulator in which the carrier waves are cut off. Finally, the demodulated signal is passed to the meter to convert the probe tip movement into linear measurement as an output signal. A separate electrical supply of D.C. is already given to actuate the meter.

2.9.3.2 Advantages of Electrical and Electronic comparator

- 1) It has less number of moving parts.
 - 2) Magnification obtained is very high.
-

- 3) Two or more magnifications are provided in the same instrument to use various ranges.
- 4) The pointer is made very light so that it is more sensitive to vibration.
- 5) The instrument is very compact.

2.9.3.3 Disadvantages of Electrical and Electronic comparator

- 1) External agency is required to meter for actuation.
- 2) Variation of voltage or frequency may affect the accuracy of output.
- 3) Due to heating coils, the accuracy decreases.
- 4) It is more expensive than mechanical comparator.

2.10 SINE BAR

Sine bars are always used along with slip gauges as a device for the measurement of angles very precisely. They are used to

- 1) Measure angles very accurately.
- 2) Locate the work piece to a given angle with very high precision.

Generally, sine bars are made from high carbon, high chromium, and corrosion resistant steel. These materials are highly hardened, ground and stabilized. In sine bars, two cylinders of equal diameter are attached at the ends with their axes mutually parallel to each other. They are also at equal distance from the upper surface of the sine bar, mostly the distance between the axes of two cylinders is 100mm, 200mm or 300mm. The working surfaces of the rollers are finished to 0.2µm R value. The cylindrical holes are provided to reduce the weight of the sine bar.

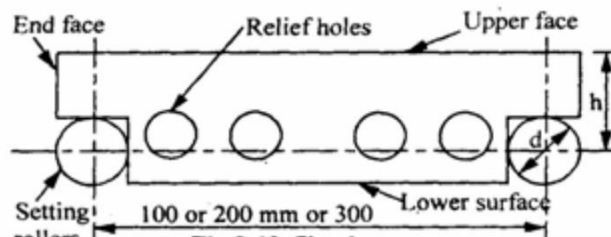

Fig 2.21 Sine Bar

2.10.1 Working principle of sine bar

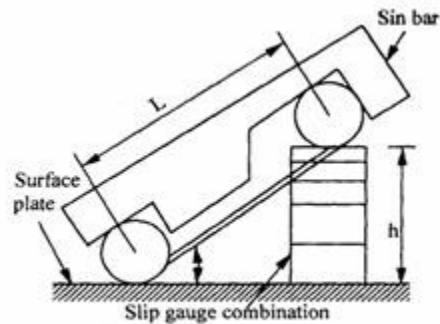

Fig 2.22 Principle of Sine bar

The working of sine bar is based on **trigonometry principle**. To measure the angle of a given specimen, one roller of the sine bar is placed on the surface plate and another roller is placed over the surface of slip gauges. Now, 'h' be the height of the slip gauges and 'L' be the distance between roller centers, then the angle is calculated as

$$\sin\theta = \frac{h}{L}$$

2.10.2 Use of Sine Bar

$$\therefore \theta = \sin^{-1}(h/L)$$

Locating any work to a given angle

- i. To set at a given angle θ , first 'h' of slip gauge is calculated by the formula $\sin\theta = h/L$
- ii. After calculating the height 'h', the required height 'h' is made by using suitable slip gauge combinations.
- iii. After this, one of the rollers is placed on the top of the sine bar and the other one is placed on the top of the slip gauge combination.

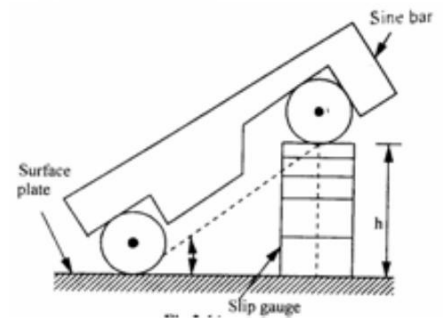

Fig 2.23 Work Location

1) Before checking the unknown angle of the specimen, first the angle (θ) of given specimen is found approximately by bevel protractor.

2) Then the sine bar is set at angle of θ and clamped on the angle plate.

3) Now, the work is placed on the sine bar and the dial indicator set at one end of the work is moved across the work piece and deviation is noted.

4) Slip gauges are adjusted so that the dial indicator reads zero throughout the work surface.

(ii) To check unknown angles:

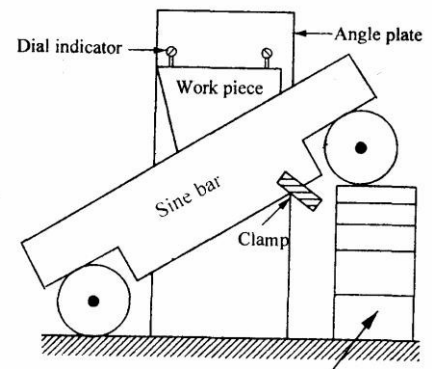

Limitations of sine bars

- 1) Sine bars are fairly reliable for angles then 15° .
- 2) It is physically difficult to hold in position.
- 3) Slight errors in sine bar cause larger angular errors.
- 4) A difference of deformation occurs at the point of roller contact with the surface plate and to the gauge blocks.
- 5) The size of parts to be inspected by sine bar is limited.

Sources of error in sine bars

The different sources of errors are listed below:

- 1) Error in distance between roller centers.
- 2) Error in slip gauge combination.
- 3) Error in checking of parallelism.
- 4) Error in parallelism of roller axes with each other.
- 5) Error in flatness of the upper surface of sine bar.

2.11 BEVEL PROTRACTORS

Bevel protractors are nothing but angular measuring instruments.

Types of bevel protractors:

The different types of bevel protractors used are:

- 1) Vernier bevel protractor
- 2) Universal protractor
- 3) Optical protractor

2.11.1 VERNIER BEVEL PROTRACTOR:

Working principle

A vernier bevel protractor is attached with acute angle attachment. The body is designed its back is flat and no projections beyond its back. The base plate is attached to the main body and an adjustable blade is

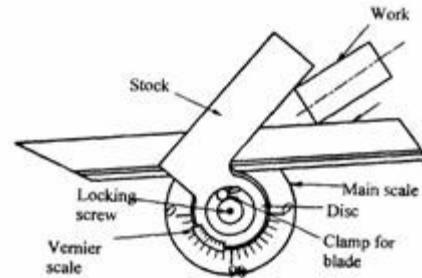

Fig 2.24 Vernier Bevel Protractor

attached to the circular plate containing Vernier scale. The main scale is graduated in degrees from 0° to 90° in both the directions. The adjustable can be made to rotate freely about the center of the main scale and it can be locked at any position. For measuring acute angle, a special attachment is provided. The base plate is made flat for measuring angles and can be moved throughout its length. The ends of the blade are beveled at angles of 45° and 60° . The main scale is graduated as one main scale division is 1° and Vernier is graduated into 12 divisions on each side of zero. Therefore the least count is calculated as

$$\begin{aligned}
 \text{Least count} &= \frac{\text{One main scale division}}{\text{No. of divisions on vernier scale}} \\
 &= \frac{1^\circ}{12} \text{ (degrees)} \\
 &= \frac{1}{12} \times 60 = 5 \text{ minutes}
 \end{aligned}$$

Thus, the bevel protractor can be used to measure to an accuracy of 5 minutes.

Applications of bevel protractor

The bevel protractor can be used in the following applications.

1. For checking a 'V' block:

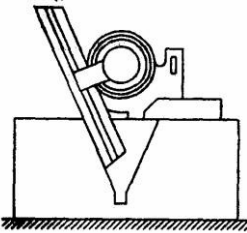

2. For measuring acute angle:

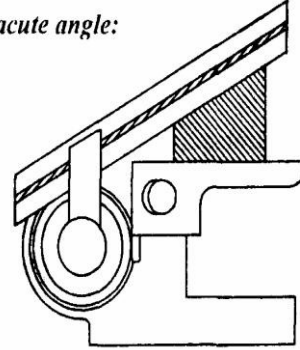

3. For checking in inside beveled face of a ground surface.

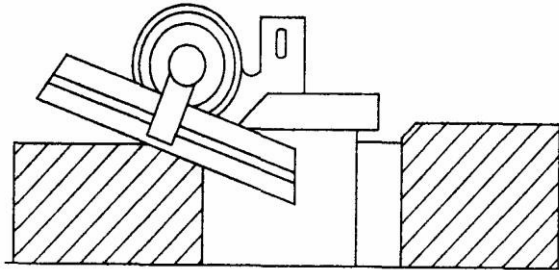

2.12 AUTO-COLLIMATOR

Auto-collimator is an optical instrument used for the measurement of small angular differences, changes or deflection, plane surface inspection etc. For small angular measurements, autocollimator provides a very sensitive and accurate approach. An auto-collimator is essentially an infinity telescope and a collimator combined into one instrument.

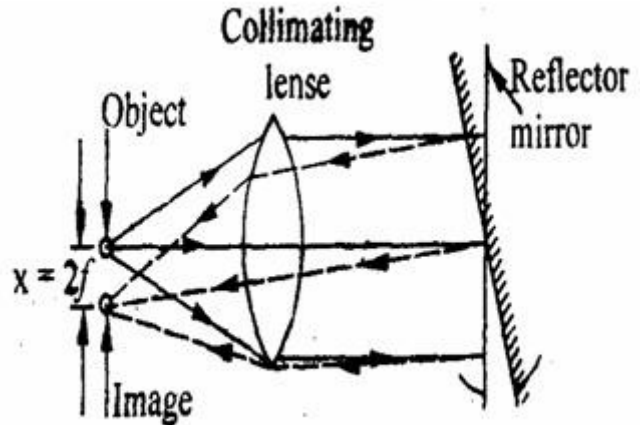

Fig 2.25 Auto-Collimator

Basic principle

If a light source is placed in the focus of a collimating lens, it is projected as a parallel beam of light. If this beam is made to strike a plane reflector, kept normal to the optical axis, it is reflected back along its own path and is brought to the same focus. The reflector is tilted through a small angle θ . Then the parallel beam is deflected twice the angle and is brought to focus in the same plane as the light source.

The distance of focus from the object is given

$$x = 2\theta \cdot f$$

Where, f = Focal length of the lens

by θ = Tilted angle of reflecting mirror.

2.12.1 WORKING OF AUTO-COLLIMATOR:

There are three main parts in auto-collimator.

1. Micrometer microscope.
2. Lighting unit and
3. Collimating lens.

Figure shows a line diagram of a modern auto-collimator. A target graticule is positioned perpendicular to the optical axis. When the target graticule is illuminated by a lamp, rays of light diverging from the intersection point reach the objective lens via beam splitter. From objective, the light rays are projected as parallel rays to the reflector.

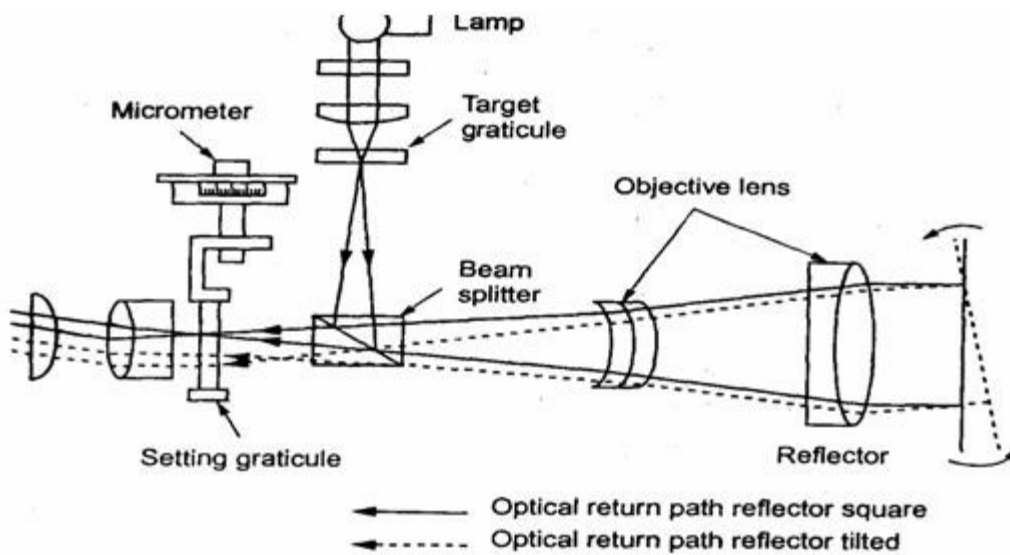

Fig 2.26 Line diagram of an injected graticule auto-collimator

A flat reflector placed in front of the objective and exactly normal to the optical axis reflects the parallel rays of light back along their original paths. They are then brought to the target graticule and exactly coincide with its intersection. A portion of the returned light passes through the beam splitter and is visible through the eyepiece. If the reflector is tilted through a small angle, the reflected beam will be changed its path at twice the angle. It can also be brought to target graticule but linearly displaced from the actual target by the amount $2\theta \times f$. linear displacement of the graticule image in the plane

tilted angle of eyepiece is directly proportional to the reflector. This can be measured by optical micrometer. The photoelectric auto-collimator is particularly suitable for calibrating polygons, for checking angular indexing and for checking small linear displacements.

2.12.2 APPLICATIONS OF AUTO-COLLIMATOR

Auto-collimators are used for

- 1) Measuring the difference in height of length standards.
- 2) Checking the flatness and straightness of surfaces.
- 3) Checking squareness of two surfaces.
- 4) Precise angular indexing in conjunction with polygons.
- 5) Checking alignment or parallelism.
- 6) Comparative measurement using master angles.
- 7) Measurement of small linear dimensions.
- 8) For machine tool adjustment testing.

2.13 ANGLE DEKKOR

This is also a type of auto-collimator. There is an illuminated scale in the focal plane of the collimating lens. This illuminated scale is projected as a parallel beam by the collimating lens which after striking a reflector below the instrument is refocused by the lens in the field of view of the eyepiece. In the field of view of microscope, there is another datum scale fixed across the center of screen. The reflected image of the illuminated scale is received at right angle to the fixed scale as shown in fig. Thus the changes in angular position of the reflector in two planes are indicated by changes in the point of intersection of the two scales. One division on the scale is calibrated to read 1 minute.

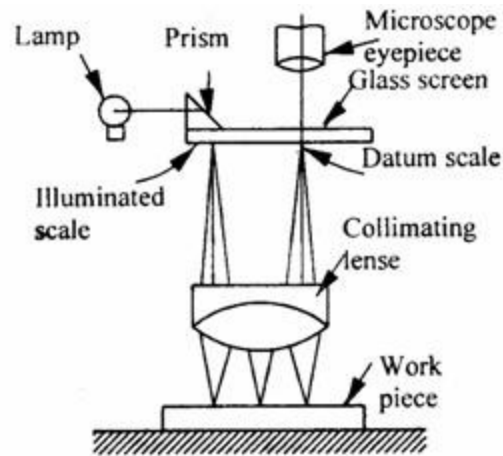

Fig 2.27 Angle Dekkor

2.13.1 Uses of Angle Dekkor

(i) Measuring angle of a component

Angle dekkor is capable of measuring small variations in angular setting i.e. determining angular tilt. Angle dekkor is used in combination with angle gauge. First the angle gauge combination is set up to the nearest known angle of the component. Now the angle dekkor is set to zero reading on the illuminated scale. The angle gauge build up is then removed and replaced by the component under test. Usually a straight edge being used to ensure that there is no change in lateral positions. The new position of the reflected scale with respect to the fixed scale gives the angular tilt of the component from the set angle

(ii) Checking the slope angle of a V-block

Figure shows the set up for checking the sloping angle of V block. Initially, a polished reflector or slip gauge is attached in close contact with the work surface. By using angle gauge zero reading is obtained in the angle dekkor. Then the angle may be calculated by comparing the reading obtained from the angle dekkor and angle gauge.

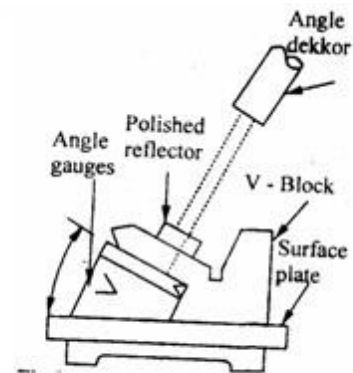

Fig 2.28 Checking of V-Slope Angle Dekkor

(iii) To measure the angle of cone or Taper gauge

Initially, the angle dekkor is set for the nominal angle of cone by using angle gauge or sine bar. The cone is then placed in position with its base resting on the surface plate. A slip gauge or reflector is attached on the cone since no reflection can be obtained from the curved surface. Any deviation from the set angle will be noted by the angle dekkor in the eyepiece and indicated by the shifting of the image of illuminated scale.

QUESTION BANK

Part-A (2 Marks)

1. List the various linear measurements?
2. What are the various types of linear measuring instruments?
3. List out any four angular measuring instrument used in metrology
4. What is comparator?
5. Classify the comparator according to the principles used for obtaining magnification.
6. How are all mechanical comparator effected?
7. State the best example of a mechanical comparator.
8. Define least count and mention the least count of a mechanical comparator.
9. How the mechanical comparator is used? State with any one example.
10. State any four advantages of reed type mechanical comparator.

Part-B (16 Marks)

1. What is the constructional difference between an autocollimator and an angle dekkor.
 2. Explain with the help of neat sketches, the principle and construction of an autocollimator
 3. What types of measuring systems are used for linear distance?
 4. Explain the working principle of mechanical comparator with a neat sketch.
 5. Explain the working principle of Electrical comparator with a neat sketch
 6. Explain the working principle of pneumatic comparator with a neat sketch
 7. Explain with the help of neat sketches, the principle and construction of an Angle dekkor.
 8. Explain the precautionary measures one shall follow at various stages of using slip gauges. Explain the process of 'Wringing' in slip gauges. Explain why sine bars are not suitable for measuring angles above 45 degrees.
 9. Describe the method of checking the angle of a taper plug gauge using rollers, micrometer and slip gauges,
 10. State and explain the "Taylor's principle of gauge design".
-

11. Explain the working principle of autocollimator and briefly explain its application
 12. Describe with the help of a neat sketch, a vernier bevel protractor.
 13. Shafts of 75 ± 0.02 mm diameter are to be checked by the help of a Go, Not Go snap gauges. Design the gauge, sketch it and show its Go size and Not Go size dimensions
Assume normal wear allowance and gauge maker's tolerance.
-
-

MODULE-III
CONCEPTS OF MEASUREMENT

CONTENTS

- 3.1 INTRODUCTION
 - 3.1.1 Screw Thread Measurement
 - 3.1.2 Screw Thread Terminology
 - 3.1.3 Error in Thread
 - 3.1.4 Measurement of various elements of Thread
 - 3.2 GEAR MEASUREMENT
 - 3.2.1 Introduction
 - 3.2.2 Types of gears
 - 3.2.3 Gear terminology
 - 3.2.4 Gear errors
 - 3.2.5 Gear Measurement
 - 3.3.6 Parkinson Gear Tester
 - 3.4 RADIUS MEASUREMENT
 - 3.5 SURFACE FINISH MEASUREMENT
 - 3.5.1 Introduction
 - 3.5.2 Elements of surface texture
 - 3.5.3 Analysis of surface finish
 - 3.5.4 Methods of measuring surface finish
 - 3.6 STRAIGHTNESS MEASUREMENT
 - 3.7 FLATNESS TESTING
 - 3.7.1 Procedure for determining flatness
 - 3.8 ROUNDNESS MEASUREMENTS
 - 3.8.1 Devices used for measurement of roundness
 - 3.8.2 Roundness measuring spindle
 - 3.8.3 Roundness measuring machine
 - 3.8.4 Modern Roundness Measuring Instruments
-

TECHNICAL TERMS

□ **Pitch**

It is the distance measured parallel to the screw threads axis between the corresponding points on two adjacent threads in the same axial plane. The basic pitch is equal to the lead divided by the number of thread starts.

□ **Lead:**

The axial distance advanced by the screw in one revolution is the lead.

□ **Addendum**

Radial distance between the major and pitch cylinders for external thread. Radial distance between the minor and pitch cylinder for internal thread.

□ **Dedendum**

It is the radial distance between the pitch and minor cylinders for external thread. Also radial distance between the major and pitch cylinders for internal thread.

□ **Pressure angle (a)**

It is the angle making by the line of action with the common tangent to the pitch circles of mating gears.

□ **Module(m)**

It is the ratio of pitch circle diameter to the total number of teeth

□ **Lead angle**

It is the angle between the tangent to the helix and plane perpendicular to the axis of cylinder.

□ **Straightness**

A line is said to be straight over a given length, if the variation of the distance of its from two planes perpendicular to each other and parallel to the general direction of the line remains within the specified tolerance limits

□ **Roundness** Roundness is defined as a condition of a surface of revolution. Where all points of the surface intersected by any plane perpendicular to a common axis in case of cylinder and cone.

3.1 INTRODUCTION

Threads are of prime importance, they are used as fasteners. It is a helical groove, used to transmit force and motion. In plain shaft, the hole assembly, the object of dimensional control is to ensure a certain consistency of fit. The performance of screw threads during their assembly with nut depends upon a number of parameters such as the condition of the machine tool used for screw cutting, work material and tool.

- Form measurement includes
- Screw thread measurement
- Gear measurement
- Radius measurement
- Surface Finish measurement
- Straightness measurement
- Flatness and roundness measurements

3.1.1 Screw Thread Measurement

Screw threads are used to transmit the power and motion, and also used to fasten two components with the help of nuts, bolts and studs. There is a large variety of screw threads varying in their form, by included angle, lead angle, helix angle etc. The screw threads are mainly classified into 1) External thread 2) Internal thread.

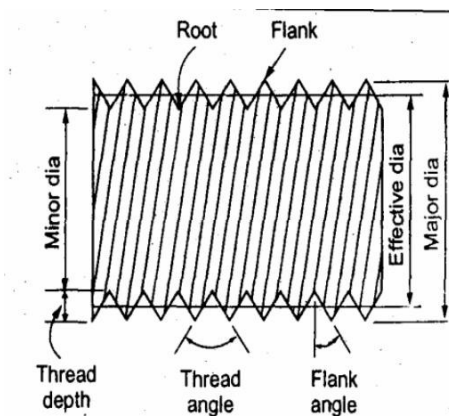

Fig 3.1 External Thread

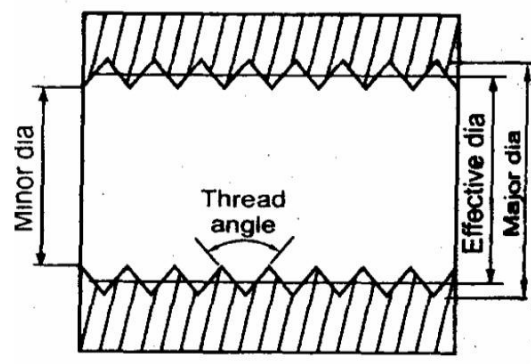

Fig 3.2 Internal Thread

3.1.2 Screw Thread Terminology

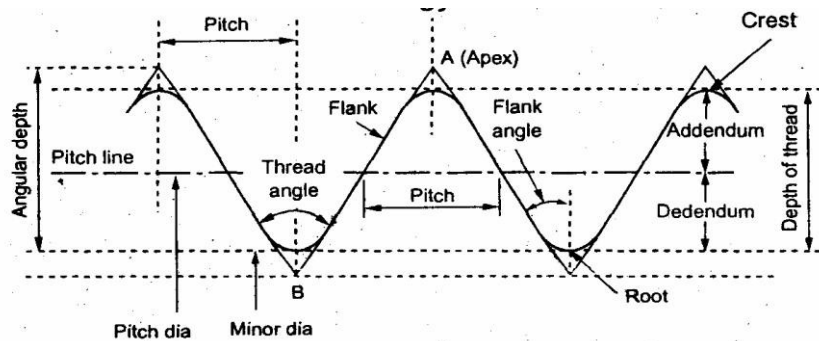

Fig 3.3 Screw Thread

□ Pitch

It is the distance measured parallel to the screw threads axis between the corresponding points on two adjacent threads in the same axial plane. The basic pitch is equal to the lead divided by the number of thread starts.

□ Minor diameter:

It is the diameter of an imaginary co-axial cylinder which touches the roots of external threads.

□ Major diameter:

It is the diameter of an imaginary co-axial cylinder which touches the crests of an external thread and the root of an internal thread.

□ Lead:

The axial distance advanced by the screw in one revolution is the lead.

□ Pitch diameter:

It is the diameter at which the thread space and width are equal to half of the screw thread.

□ Helix angle:

It is the angle made by the helix of the thread at the pitch line with the axis. The angle is measured in an axial plane.

□ **Flank angle:**

It is the angle between the flank and a line normal to the axis passing through the apex of the thread.

□ **Height of thread:**

It is the distance measured radially between the major and minor diameters respectively

□ **Addendum:**

Radial distance between the major and pitch cylinders for external thread.
Radial distance between the minor and pitch cylinder for internal thread.

□ **Dedendum:**

It is the radial distance between the pitch and minor cylinders for external thread. Also radial distance between the major and pitch cylinders for internal thread.

3.1.3 Error in Thread

The errors in screw thread may arise during the manufacturing or storage of threads. The errors either may arise in following six main elements in the thread.

- 1) Major diameter error
- 2) Minor diameter error
- 3) Effective diameter error
- 4) Pitch error
- 5) Flank angles error
- 6) Crest and root error

1) Major diameter error

It may cause reduction in the flank contact and interference with the matching threads.

2) Minor diameter error

It may cause interference, reduction of flank contact.

3) Effective diameter error

If the effective diameter is small the threads will be thin on the external screw and thick on an internal screw.

4) Pitch errors

If error in pitch, the total length of thread engaged will be either too high or too small.

The various pitch errors may be classified into

1. Progressive error
2. Periodic error
3. Drunken error
4. Irregular error

1) Progressive error

The pitch of the thread is uniform but is longer or shorter than its nominal value and this is called progressive.

Causes of progressive error:

1. Incorrect linear and angular velocity ratio.
2. Incorrect gear train and lead screw.
3. Saddle fault.
4. Variation in length due to hardening.

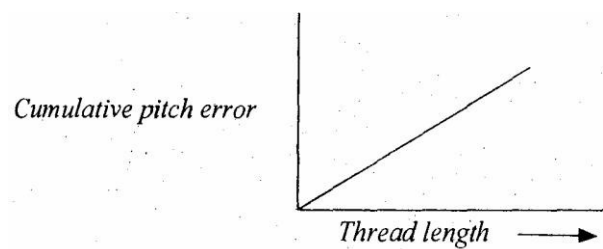

Fig 3.4 Progressive Error

2) Periodic error

These repeat themselves at regular intervals along the thread

Causes of periodic error:

1. Ununiform tool work velocity ratio.

2. Teeth error in gears.
3. Lead screw error.
4. Eccentric mounting of the gears.

3) Drunken error

Drunken errors are repeated once per turn of the thread in a drunken thread. In Drunken thread the pitch measured parallel to the thread axis. If the thread is not cut to the true helix the drunken thread error will form

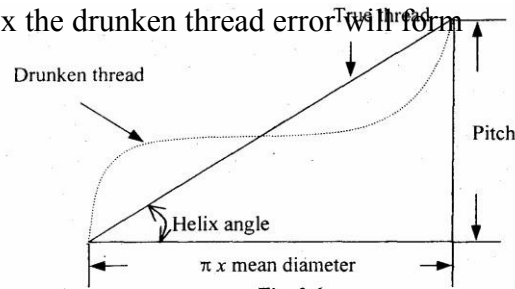

Fig 3.5 Drunken Error

4) Irregular errors

It is vary irregular manner along the length of the thread.

Irregular error causes:

1. Machine fault.
2. Non-uniformity in the material.
3. Cutting action is not correct.
4. Machining disturbances.

Effect of pitch errors

- Increase the effective diameter of the bolt and decreases the diameter of nut.
- The functional diameter of the nut will be less.
- Reduce the clearance.
- Increase the interference between mating threads.

3.1.4 Measurement of various elements of Thread

To find out the accuracy of a screw thread it will be necessary to measure the following:

1. Major diameter.
2. Minor diameter.
3. Effective or Pitch diameter.
4. Pitch
5. Thread angle and form

1. Measurement of major diameter:

The instruments which are used to find the major diameter are by

- Ordinary micrometer
- Bench micrometer.

□ Ordinary micrometer

The ordinary micrometer is quite suitable for measuring the external major diameter. It is first adjusted for appropriate cylindrical size (S) having the same diameter (approximately). This process is known as 'gauge setting'. After taking this reading 'R' the micrometer is set on the major diameter of the thread, and the new reading is 'R2'.

□ Bench micrometer

For getting the greater accuracy the bench micrometer is used for measuring the major diameter. In this process the variation in measuring pressure, pitch errors are being neglected. The fiducial indicator is used to ensure all the measurements are made at same pressure. The instrument has a micrometer head with a vernier scale to read the accuracy of 0.002mm. Calibrated setting cylinder having the same diameter as the major diameter of the thread to be measured is used as setting standard. After setting the standard, the setting cylinder is held between the anvils and the reading is taken. Then the cylinder is replaced by the threaded work piece and the new reading is taken.

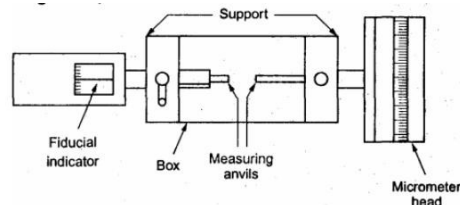

Fig 3.6 Bench Micrometer

∴ The major diameter of screw thread

$$= S \pm (D_2 - D_1)$$

Where, S = Diameter of the setting cylinder.

R_2 = Micrometer Reading on screw thread

R_1 = Micrometer reading on setting cylinder.

□ Measurement of the major diameter of an Internal thread

The Inter thread major diameter is usually measured by thread comparator fitted with ball-ended styli. First the Instrument is set for a cylindrical reference having the same diameter as the major diameter of internal thread and the reading is taken. Then the

floating head is retracted to engage the tips of the styli at the root of spring under pressure. For t at t e new reading is taken.

D = Cylindrical standard diameter

R_2 = Thread reading

R_1 = Dial Indicator reading on the standard.

2. Measurement of Minor diameter

The minor diameter is measured by a comparative method by using floating carriage diameter measuring machine and small V pieces which make contact with the root of the thread. These V pieces are made in several sizes, having suitable radii at the edges. V pieces are made of hardened steel. The floating carriage diameter-measuring machine is a bench micrometer mounted on a carriage.

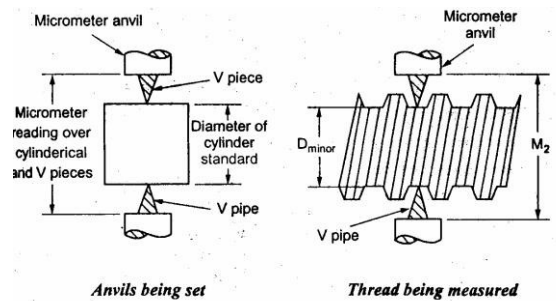

Fig 3.7 Measurement of Minor diameter

□ Measurement process

The threaded work piece is mounted between the centers of the instrument and the V pieces are placed on each side of the work piece and then the reading is noted. After taking this reading the work piece is then replaced by a standard reference cylindrical setting gauge.

The minor diameter of the thread = $D \pm (R_2 - R_1)$

Where, D = Diameter of cylindrical gauge

R_2 = Micrometer reading on threaded work piece.

R_1 = Micrometer reading on cylindrical gauge.

□ Measurement of Minor diameter of Internal threads

The Minor diameter of Internal threads are measured by

1. Using taper parallels
2. Using Rollers

□ Using taper parallels

For diameters less than 200mm the use of Taper parallels and micrometer is very common. The taper parallels are pairs of edges having reduced and parallel outer

edges. The diameter across their outer edges can be changed by sliding them over each other.

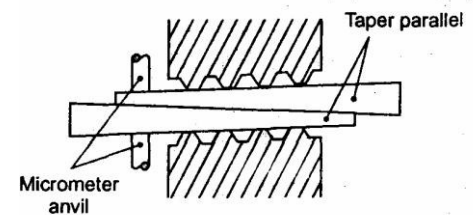

Fig 3.8 Taper parallels

□ Using rollers

For more than 20mm diameter this method is used. Precision rollers are inserted inside the thread and proper slip gauge is inserted between the rollers. The minor diameter is then the length of slip gauges plus twice the diameter of roller.

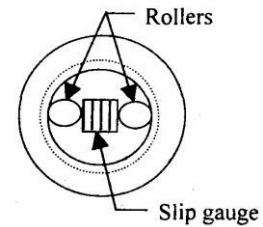

Fig 3.9 Roller gauge

3. Measurement of effective diameter

Effective diameter measurement is carried out by following methods.

1. One wire,
2. Two wires, or
3. Three wires method.
4. Micrometer method.

a) One wire method

The only one wire is used in this method. The wire is placed between two threads at one side and on the other side the anvil of the measuring micrometer contacts the crests. First the micrometer reading d_1 is noted on a standard gauge whose dimension is approximately same to be obtained by this method.

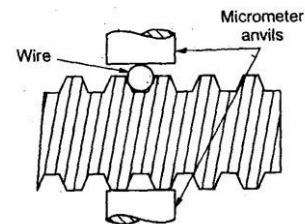

Fig 3.10 One wire method

i.e. ' d_2 ' then effective diameter = $D \pm (d_1 - d_2)$

When D = Size of setting gauge

Actual measurement over wire on one side and threads on other

b) Two wire method

Two-wire method of measuring the effective diameter of a screw thread is given below. In this method wires of suitable size are placed between the standard and the micrometer anvils. First the micrometer reading is taken and let it be R . Then the standard is replaced by the screw thread to be measured and the new reading

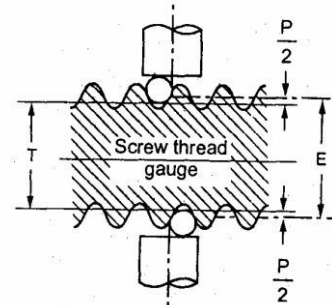

Fig 3.11 Two Wire Method

is taken.

From the above reading

The effective diameter E is calculated by $E = T + P$

Where, $T =$ Dimension under the wires $= M - 2d$

$M =$ Dimension over the wires

$d =$ diameter of each wire

If $P' =$ Pitch of thread then

$$P = 0.9605 P' - 1.1657d \Rightarrow \text{Whitworth thread.}$$

$$P = 0.866 P' - d \Rightarrow \text{For metric thread.}$$

Here, $P =$ The difference between the effective diameter and the diameter under the wires.

The diameter under the wires ' T ' also can be determined by

$$T = S - (R_1 - R_2)$$

Where, $S =$ The diameter of the standard.

The P value can be derived in terms of P (Pitch), d (Diameter of wire) and x thread angle is as follows

BC lies on the effective diameter.

$$\therefore BC = \frac{1}{2} \text{Pitch} = \frac{1}{2} P$$

$$\text{Next } OP = \frac{d \operatorname{Cosec}(x/2)}{2}$$

$$\text{And } AQ = PQ - AP$$

Where,

$$PQ = QC \operatorname{Cot}(x/2) = P/4 \operatorname{Cot}(x/2)$$

$$PQ = \frac{P}{4} \operatorname{Cot}(x/2)$$

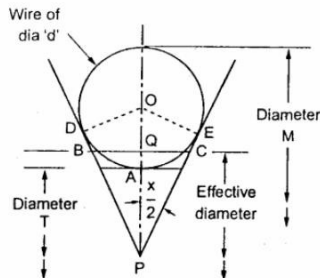

c) Three-Wire method

The three-wire method is the accurate method. In this method three wires of equal and precise diameter are placed in the grooves at opposite sides of the screw. In this one wire on one side and two on the other side are used. The wires either may be held in hand or hung from a stand. This method ensures the alignment of micrometer anvil faces parallel to the thread axis.

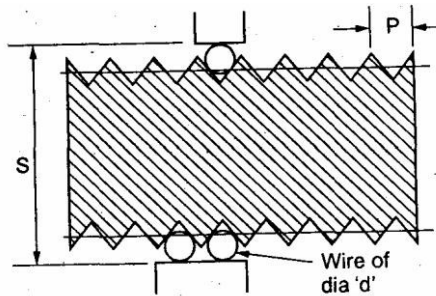

**Fig 3.13 Pitch
Measuring Machine**

□ BEST WIRE SIZE-DEVIATION

Best wire diameter is that may contact with the flanks of the thread on the pitch line. The figure shows the wire makes contact with the flanks of the thread on the pitch.

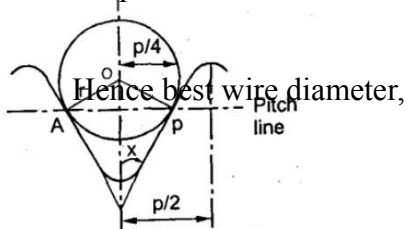

Where, db = Wire diameter

x = Included angle

$$AP = p/4$$

$$\therefore db = 2 p/4 \sec x$$

$$db = p_2 \sec x$$

4. Pitch measurement

The most commonly used methods for measuring the pitch are

1. Pitch measuring machine
2. Tool maker's microscope
3. Screw pitch gauge

□ Pitch measuring machine

The principle of the method of measurement is to move the stylus along the screw parallel to the axis from one space to the next. The pitch-measuring machine provides a relatively simple and accurate method of measuring the pitch. Initially the micrometer reading is near the zero on the scale, the indicator is moved along to bring the stylus, next the indicator adjusted radially until the stylus engages between the thread flank and the pointer 'K' is opposite in the line L. To bring T in opposite in its index mark a small movement is necessary in the micrometer and then the reading is taken next. The stylus is moved along into the next space by rotation of the micrometer and the second reading is taken. The difference between these two-measured readings is known as the pitch of the thread.

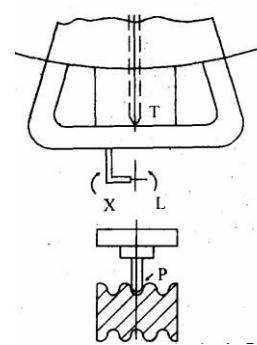

□ Tool makers microscope

Working

Worktable is placed on the base of the instrument. The optical head is mounted on a vertical column it can be moved up and down. Work piece is mounted on a glass plate. A light source

provides horizontal beam of light which is reflected from a mirror by 90° upwards towards the table.

Image of the outline contour of the work piece passes through the objective of the optical head. The image is projected by a system of three prisms to a ground glass screen. The measurements are made by means of cross lines engraved on the ground glass screen. The screen can be rotated through 360°. Different types of graduated screens and types are used.

□ Applications

- Linear measurements.
- Measurement of pitch of the screw.
- Measurement of pitch diameter.
- Measurement of thread angle.
- Comparing thread forms.
- Centre to centre distance measurement.
- Thread form and flank angle measurement

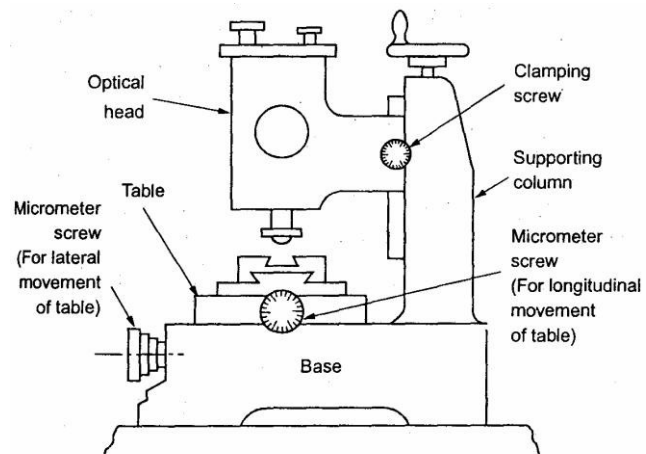

Fig 3.14 Tool Makers Microscope

- **Thread form and flank angle measurement**

The optical projectors are used to check the thread form and angles of the thread. The projectors equipped with work holding fixtures, lamp, and lenses. The light rays from the lens are directed into the cabinet and prisms and mirrors. The enlarged image of thread is drawn. The ideal and actual forms are compared for the measurement.

3.2 GEAR MEASUREMENT

3.2.1 Introduction

Gear is a mechanical drive which transmits power through toothed wheel. In this gear drive, the driving wheel is in direct contact with driven wheel. The accuracy of gearing is the very important factor when gears are manufactured. The transmission efficiency is almost 99% in gears. So it is very important to test and measure the gears precisely. For proper inspection of gear, it is very important to concentrate on the raw materials, which are used to manufacture the gears, also very important to check the machining the blanks, heat treatment and the finishing of teeth. The gear blanks should be tested for dimensional accuracy and tooth thickness for the forms of gears.

The most commonly used forms of gear teeth are

1. Involute
2. Cycloidal

The involute gears also called as straight tooth or spur gears. The cycloidal gears are used in heavy and impact loads. The involute rack has straight teeth. The involute pressure angle is either 20° or 14.5° .

3.2.2 Types of gears

1. Spur gear

Cylindrical gear whose tooth traces is straight line. These are used for transmitting power between parallel shafts.

2. Spiral gear

The tooth of the gear traces curved lines.

3. Helical gears

These gears used to transmit the power between parallel shafts as well as nonparallel and non-intersecting shafts. It is a cylindrical gear whose tooth traces a straight line.

4. Bevel gears:

The tooth traces are straight-line generators of cone. The teeth are cut on the conical surface. It is used to connect the shafts at right angles.

5. Worm and Worm wheel:

It is used to connect the shafts whose axes are non-parallel and non-intersecting.

6. Rack and Pinion:

Rack gears are straight spur gears with infinite radius.

3.2.3 Gear terminology

1. Tooth profile

It is the shape of any side of gear tooth in its cross section.

2. Base circle

It is the circle of gear from which the involute profile is derived. Base circle diameter = Pitch circle diameter \times Cosine of pressure angle of gear

3. Pitch circle diameter (PCD)

The diameter of a circle which will produce the same motion as the toothed gear wheel

4. Pitch circle

It is the imaginary circle of gear that rolls without slipping over the circle of its mating gear.

5. Addendum circle

The circle coincides with the crests (or) tops of teeth.

6. Dedendum circle (or) Root circle

This circle coincides with the roots (or) bottom on teeth.

7. Pressure angle (a)

It is the angle making by the line of action with the common tangent to the pitch circles of mating gears.

8. Module(m)

It is the ratio of pitch circle diameter to the total number of teeth. Where,
 $d = \text{Pitch circle diameter. } n = \text{Number of teeth.}$

9. Circular pitch

It is the distance along the pitch circle between corresponding points of adjacent teeth.

10. Addendum

Radial distance between tip circle and pitch circle. Addendum value = 1 module.

11 Dedendum

Radial distance between pitch circle and root circle,
Dedendum value = 1.25module.

12. Clearance (C)

Amount of distance made by the tip of one gear with the root of mating gear.
Clearance = Difference between Dedendum and addendum values.

13. Blank diameter:

The diameter of the blank from which gear is cut. Blank diameter = $PCD + 2m$

14. Face:

Part of the tooth in the axial plane lying between tip circle and pitch circle.

15. Flank:

Part of the tooth lying between pitch circle and root circle.

16. Top land:

Top surface of a tooth.

17. Lead angle

The angle between the tangent to the helix and plane perpendicular to the axis of cylinder.

18. Backlash:

The difference between the tooth thickness and the space into which it meshes. If we assume the tooth thickness as t and width as t then

$$\text{Backlash} = t_2 - t_1$$

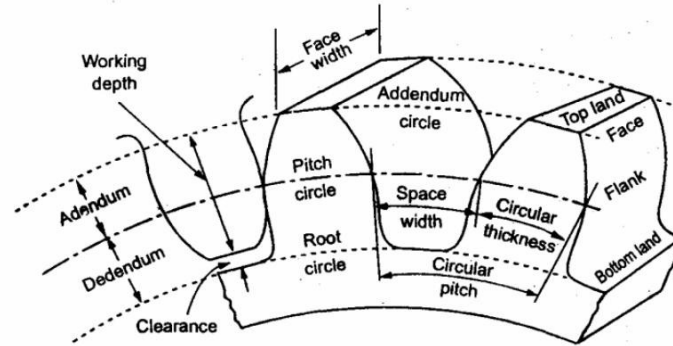

Fig 3.15 Gear Profile

3.2.4 Gear errors

- 1. Profile error:** - The maximum distance of any point on the tooth profile from the design profile.
 - 2. Pitch error:** - Difference between actual and design pitch
 - 3. Cyclic error:** - Error occurs in each revolution of gear
 - 4. Run out:** - Total range of reading of a fixed indicator with the contact points applied to a surface rotated, without axial movement, about a fixed axis.
 - 5. Eccentricity:** - Half the radial run out
 - 6. Wobble:** - Run out measured parallel to the axis of rotation at a specified distance from the axis
 - 7. Radial run out:** - Run out measured along a perpendicular to the axis of rotation.
 - 8. Undulation:** - Periodical departure of the actual tooth surface from the design surface.
 - 9. Axial run out:** - Run out measured parallel to the axis of rotation at a speed.
 - 10. Periodic error:** - Error occurring at regular intervals.
-

3.2.5 Gear Measurement

The Inspection of the gears consists of determine the following elements in which manufacturing error may be present.

1. Runout.
2. Pitch
3. Profile
4. Lead
5. Back lash
6. Tooth thickness
7. Concentricity
8. Alignment

1. Runout:

It means eccentricity in the pitch circle. It will give periodic vibration during each revolution of the gear. This will give the tooth failure in gears. The run out is measured by means of eccentricity testers. In the testing the gears are placed in the mandrel and the dial indicator of the tester possesses special tip depending upon the module of the gear and the tips inserted between the tooth spaces and the gears are rotated tooth by tooth and the variation is noted from the dial indicator.

2. Pitch measurement:

There are two ways for measuring the pitch.

1. Point to point measurement (i.e. One tooth point to next tooth point)
2. Direct angular measurement

1. Tooth to Tooth measurement

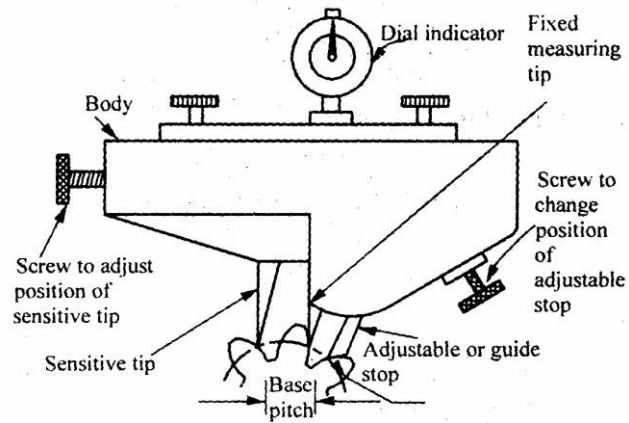

Fig 3.16 Tooth to tooth measurement

The instrument has three tips. One is fixed measuring tip and the second is sensitive tip, whose position can be adjusted by a screw and the third tip is adjustable or guide stop. The distance between the fixed and sensitive tip is equivalent to base pitch of the gear. All the three tips are contact the tooth by setting the instrument and the reading on the dial indicator is the error in the base pitch.

2. Direct Angular Measurement

It is the simplest method for measuring the error by using set dial gauge against a tooth. In this method the position of a suitable point on a tooth is measured after the gear has been indexed by a suitable angle. If the gear is not indexed through the angular pitch the reading differs from the original reading. The difference between these is the cumulative pitch error.

3. Profile checking

The methods used for profile checking is

1. Optical projection method.
2. Involute measuring machine.

1. Optical projection method:

The profile of the gear projected on the screen by optical lens and then projected value is compared with master profile.

2. Involute measuring machine:

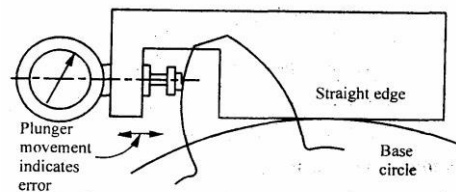

Fig 3.17 Involute Measuring Machine

In this method the gear is held on mandrel and circular disc of same diameter as the base circle of gear for the measurement is fixed on the mandrel. After fixing the gear in the mandrel, the straight edge of the instrument is brought in contact with the base circle of the disc. Now, the gear and disc are rotated and the edge moves over the disc without slip. The stylus moves over the tooth profile and the error is indicated on the dial gauge.

4. Lead checking:

It is checked by lead checking instruments. Actually lead is the axial advance of a helix for one complete turn. The lead checking instruments advance a probe along a tooth surface, parallel to the axis when the gear rotates.

5. Backlash checking:

Backlash is the distance through which a gear can be rotated to bring its non working flank in contact with the teeth of mating gear. Numerical values of backlash are measured at the tightest point of mesh on the pitch circle. There are two types of backlash

1. Circumferential backlash
 2. Normal backlash
-

The determination of backlash is, first one of the two gears of the pair is locked, while other is rotated forward and backward and by the comparator the maximum displacement is measured. The stylus of comparator is locked near the reference cylinder and a tangent to this is called circular backlash.

6. Tooth thickness measurement:

Tooth thickness is generally measured at pitch circle and also in most cases the chordal thickness measurement is carried out i.e. the chord joining the intersection of the tooth profile with the pitch circle.

The methods which are used for measuring the gear tooth thickness is

- a) Gear tooth vernier caliper method (Chordal thickness method)
- b) Base tangent method.
- c) Constant chord method.
- d) Measurement over pins or balls.

a) Gear tooth vernier method

In gear tooth vernier method the thickness is measured at the pitch line. Gear tooth thickness varies from the tip of the base circle of the tooth, and the instrument is capable of measuring the thickness at a specified position on the tooth. The tooth vernier caliper consists of vernier scale and two perpendicular arms. In the two perpendicular arms one arm is used to measure the thickness and other arm is used to measure the depth. Horizontal vernier scale reading gives chordal thickness (W) and vertical vernier scale gives the chordal addendum. Finally the two values compared.

The theoretical values of W and d can be found out by considering one tooth in the gear and it can be verified. In fig noted that w is a chord ADB and tooth thickness is specified by AEB . The distance d is noted and adjusted on instrument and it is slightly greater than addendum CE .

∴ 'W' is chordal thickness and 'd' is named as chordal addendum.

$$\text{So, } W = AB = 2AD$$

$$\text{And angle, } \angle AOD = \theta = \frac{360}{n}$$

Where, $n = \text{Number of teeth.}$

$$W = 2AD = 2 \times AO \sin \theta$$

$$= 2R \sin \frac{360}{4n} \dots\dots$$

Where, $R = \text{Pitch circle radius}$

$$\text{Module, } m = \frac{P.C.D}{\text{No. of teeth}} = \frac{2R}{n}$$

$$\therefore R = \frac{nm}{2}$$

$$\text{And } OD = R \cos \theta = \frac{nm}{2} \cos \left(\frac{90}{n} \right)$$

$$\boxed{OD = \frac{nm}{2} \cos \left(\frac{90}{n} \right)}$$

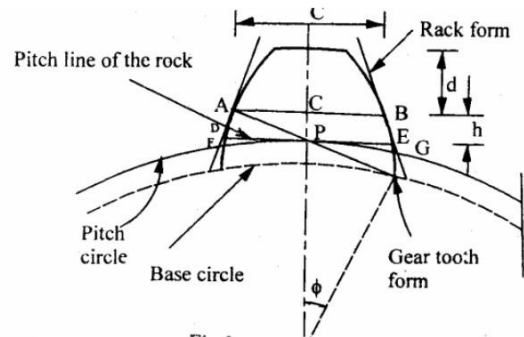

Vernier method like the chordal thickness and chordal addendum are dependent upon the number of teeth. Due to this for measuring large number of gears different calculations are to be made for each gear. So these difficulties are avoided by this constant chord method.

b) Measurement over Rolls or balls

A very good and convenient method for measuring thickness of gear. In this method two or three different size rollers are used for checking the vibrations at several places on the tooth.

7. Measurement of concentricity

In setting of gears the centre about which the gear is mounted should be coincident with the centre from which the gear is generated. It is easy to check the concentricity of the gear by mounting the gear between centres and measuring the

variation in height of a roller placed between the successive teeth. Finally the variation in reading will be a function of the eccentricity present.

8. Alignment checking

It is done by placing a parallel bar between the gear teeth and the gear being mounted between centres. Finally the readings are taken at the two ends of the bar and difference in reading is the misalignment.

3.3.6 Parkinson Gear Tester

Working principle

The master gear is fixed on vertical spindle and the gear to be tested is fixed on similar spindle which is mounted on a carriage. The carriage which can slide either side of these gears are maintained in mesh by spring pressure. When the gears are rotated, the movement of sliding carriage is indicated by dial indicator and these variations are measure of any irregularities. The variation is recorded in a recorder which is fitted in the form of a waxed circular chart. In the gears are fitted on the mandrels and are free to rotate without clearance and the left mandrel move along the table and the right mandrel move along the spring-loaded carriage.

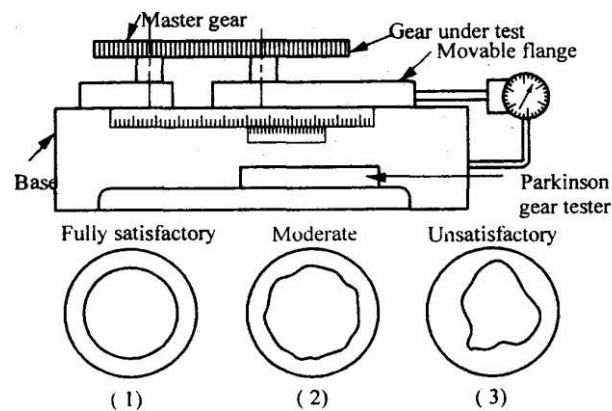

Fig 3.18 Parkinson Gear Tester

The two spindles can be adjusted so that the axial distance is equal and a scale is attached to one side and vernier to the other, this enables center distance to be measured to within 0.025mm. If any errors in the tooth form when gears are in close mesh, pitch or

Fig 3.19 Radius Measurement

concentricity of pitch line will cause a variation in center distance from this movement of carriage as indicated to the dial gauge will show the errors in the gear test. The recorder also fitted in the form of circular or rectangular chart and the errors are recorded

□ Limitations of Parkinson gear tester:

1. Accuracy \pm 0.001mm
2. Maximum gear diameter is 300mm
3. Errors are not clearly identified:
4. Measurement dependent upon the master gear.
5. Low friction in the movement of the floating carriage.

3.4 RADIUS MEASUREMENT

In radius measurement we are going to see about two methods namely.

1. Radius of circle and
2. Radius of concave surface

1. Radius of circle

This radius measurement requires the use of vernier caliper, C-Clamp, surface plate and two pins. This method is very much used

in measuring the cap of bearing. Initially the job is fixed on surface plate with the help of

C-clamp. So that the central position of the circular part is in touch with the surface plate. Next the two balls are placed on both sides of the work and using the vernier caliper readings are taken.

Let, R = Radius of job, I = The reading between two balls

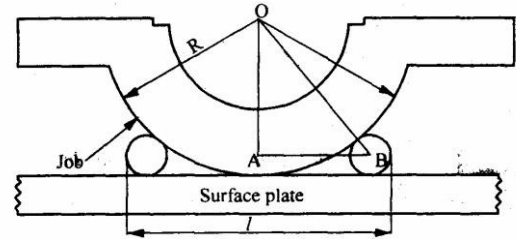

Now, from fig. $OB^2 = OA^2 + AB^2$
 It is written like this

$$(R + d/2)^2 = (R - d/2)^2 + \left(\frac{l-d}{2}\right)^2$$

$$R^2 + (d/2)^2 + 2Rd/2 = R^2 + d^2/4 - 2Rd/2 + \left(\frac{l-d}{2}\right)^2$$

$$2Rd = \frac{(l-d)^2}{4}$$

$$\therefore Rd = \frac{(l-d)^2}{8}$$

$$d = \frac{(l-d)^2}{8d}$$

2. Radius of concave surface

Here there are two methods

- Edges are well defined.
- Edges are rounded up

▫ Edges are well defined

In this method radius is calculated by using surface plate, height gauge, angle plate, C-clamp and slip gauges. First the job placed on the surface plate and

then by using depth micrometer the depth is measured and it is h.

Next in such a way that cavity is resting against an angle plate and the part is clamped in this position. By using a height gauge edge

to edge size of hole is measured and this is

diameter of d.

From the above fig.

Let, O = Centre of the cavity

From the above fig.

$$OA^2 = AB^2 + BO^2 \quad \text{Here, } OA = R$$

$$R^2 = \left(\frac{d}{2}\right)^2 + (R-h)^2$$

$$= \frac{d^2}{4} + R^2 + h^2 - 2Rh$$

$$R = \frac{\frac{d^2}{4} + h^2}{2h} = \frac{d^2}{8h} + \frac{h}{2}$$

∴ Radius $R = \frac{d^2}{8h} + \frac{h}{2}$

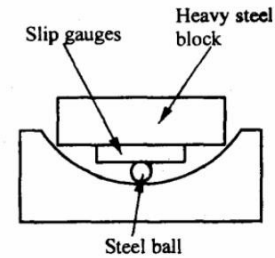

Fig 3.20 R dius of Concave surface

When cavities are rounded up the radius is measured by depth micrometer and slip gauges. First the width of the micrometer is measured by slip gauges and it is let 'd'. Then it is placed in the cavity and measuring tip is lowered down to touches the base. From this condition the reading is noted and it be h and the radius is measured by using the formula

2) Edges are rounded up

When cavities are rounded up the radius is measured by depth micrometer and slip gauges. First the width of the micrometer is measured by slip gauges and it is let 'd'. Then it is placed in the cavity and measuring tip is lowered down to touches the base. From this condition the reading is noted and it be h and the radius is measured by using the formula

$$R = \frac{d^2}{8h} + \frac{h^2}{2}$$

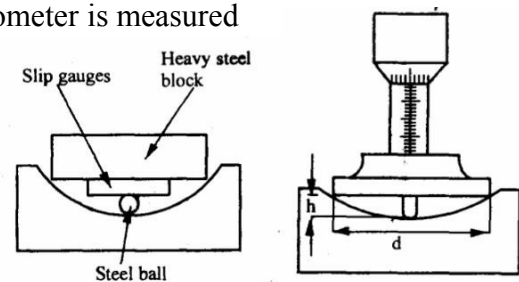

Fig 3.21 Edges round up

3.5 SURFACE FINISH MEASUREMENT

3.5.1 Introduction

When we are producing components by various methods of manufacturing process it is not possible to produce perfectly smooth surface and some irregularities are formed. These irregularities cause some serious difficulties in using the components. So it is very important to correct the surfaces before use. The factors which are affecting surface roughness are

1. Work piece material
2. Vibrations
3. Machining type
4. Tool and fixtures

1. First order
2. Second order
3. Third order
4. Fourth order

1. First order irregularities

These are caused by lack of straightness of guide ways on which tool must move

2. Second order irregularities These are caused by vibrations

3. Third order irregularities

These are caused by machining.

4. Fourth order irregularities

These are caused by improper handling machines and equipments.

3.5.2 Elements of surface texture

1. **Profile:** - Contour of any section through a surface.
2. **Lay:** - Direction of the 'predominate surface pattern'
3. **Flaws:** - Surface irregularities or imperfection, which occur at infrequent intervals
4. **Actual surface:** - Surface of a part which is actually obtained,
5. **Roughness:** - Finely spaced irregularities. It is also called primary texture.

6. **Sampling lengths:** - Length of profile necessary for the evaluation of the irregularities.

7. **Waviness:** - Surface irregularities which are of greater spacing than roughness.

8. **Roughness height:** - Rated as the arithmetic average deviation.

9. **Roughness width:** - Distance parallel to the normal surface between successive peaks.

10. **Mean line of profile:** - Line dividing the effective profile such that within the sampling length.

11. **Centre line of profile:** - Line dividing the effectiveness profile such that the areas embraced by profile above and below the line are equal.

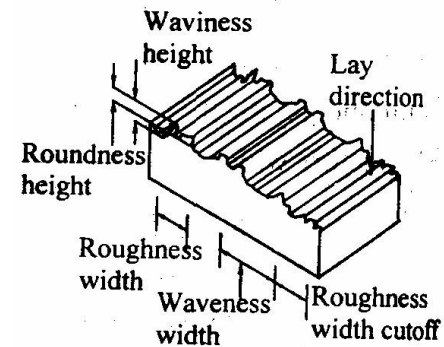

Fig 3.22 Surface Texture

3.5.3 Analysis of surface finish

The analyses of surface finish being carried out by

1. The average roughness method.
2. Peak to valley height method
3. Form factor

1. Average roughness measurement

The assessment of average roughness is carried out by

- a Centre line average (CLA).
- b Root mean square (RMS)
- c Ten point method

a. C.L.A. method

The surface roughness is measured as the average deviation from the nominal surface.

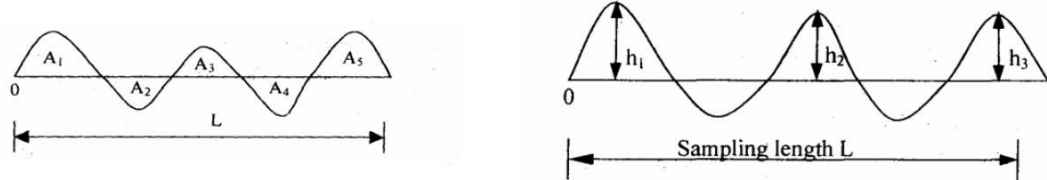

$$\text{C. L. A. Value} = \frac{A_1 + A_2 + A_3 + \dots + A_n}{L}$$

$$\text{C. L. A.} = \frac{\sum A}{L}$$

Where, $\sum A$ = Average area
 L = Total length

b. R.M.S. method

The roughness is measured as the average deviation from the nominal surface. Let, h_1, h_2, \dots are the heights of the ordinates and L is the sampling length

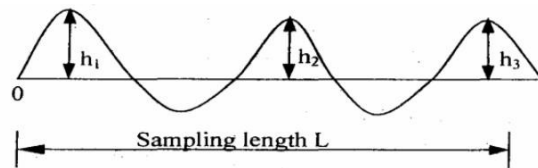

$$\text{R.M.S. average} = \sqrt{\frac{h_1^2 + h_2^2 + h_3^2 + \dots + h_n^2}{n}}$$

c. Ten point height method

The average difference between five highest peaks and five lowest valleys of surface is taken and irregularities are calculated by

$$S_2 = \frac{1}{5} (h_1 + h_2 + h_3 + h_4 + h_5) - (h_6 + h_7 + h_8 + h_9 + h_{10})$$

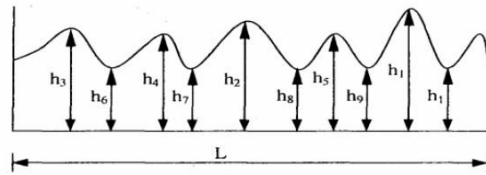

2. Peak to valley height method

Peak to valley height measures the maximum depth of the surface irregularities over a given sample length and largest value of the depths accepted for the measurement.

Here, $=$ Maximum peak to valley height in one sampling lengths.

R = Maximum peak to valley height

V = Valley

P = Peak

Here, R is the maximum peak to valley height within the assessment length and the disadvantages of R , and is only a single peak or valley which gives the value is not a true picture of the actual profile of the surface

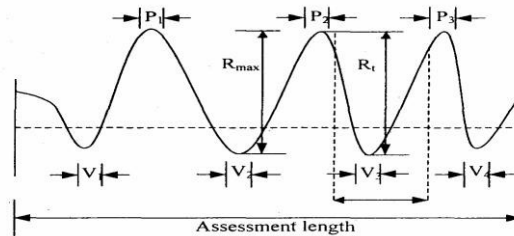

3. Form factor

It is obtained by measuring the area of material above the arbitrarily chosen base line in the section and the area of the enveloping rectangle.

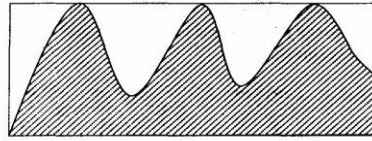

Fig 3.23 Form factor

$$\text{Degree of fullness } (F) = \frac{\text{Metal Area}}{\text{Enveloping rectangle Area}}$$

$$\text{Degree of emptiness, } (E_1) = 1 - F$$

3.5.4 Methods of measuring surface finish

The methods used for measuring the surface finish is classified into

1. Inspection by comparison
2. Direct Instrument Measurements

1. Inspection by comparison methods:

In these methods the surface texture is assessed by observation of the surface. The surface to be tested is compared with known value of roughness specimen and finished by similar machining processes.

The various methods which are used for comparison are

1. Touch Inspection.
2. Visual Inspection.
3. Microscopic Inspection.
4. Scratch Inspection.
5. Micro Interferometer.
6. Surface photographs.
7. Reflected Light Intensity.
8. Wallace surface Dynamometer.

□ Touch Inspection

It is used when surface roughness is very high and in this method the fingertip is moved along the surface at a speed of 25mm/second and the irregularities as up to 0.0125mm can be detected.

□ **Visual Inspection**

In this method the surface is inspected by naked eye and this measurement is limited to rough surfaces.

□ **Microscopic Inspection**

In this method finished surface is placed under the microscope and compared with the surface under inspection. The light beam also used to check the finished surface by projecting the light about 60° to the work.

□ **Scratch Inspection:**

The materials like lead, plastics rubbed on surface are inspected by this method. The impression of this scratches on the surface produced is then visualized.

□ **Micro-Interferometer**

Optical flat is placed on the surface to be inspected and illuminated by a monochromatic source of light.

□ **Surface Photographs**

Magnified photographs of the surface are taken with different types of illumination. The defects like irregularities appear as dark spots and flat portion of the surface appears as bright.

□ **Reflected light Intensity**

A beam of light is projected on the surface to be inspected and the light intensity variation on the surface is measured by a photocell and this measured value is calibrated

□ **Wallace surface Dynamometer:**

It consists of a pendulum in which the testing shoes are clamped to a bearing surface and a pre determined spring pressure can be applied and then, The pendulum is lifted to its initial starting position and allowed to swing over the surface to be tested.

2. Direct instrument measurements

Direct methods enable to determine a numerical value of the surface finish of any surface. These methods are quantitative analysis methods and the output is used to operate recording or indicating instrument. Direct Instruments are operated by electrical principles. These instruments are classified into two types according to the operating principle. In this is operated by carrier-modulating principle and the other is operated by voltage-generating principle, and in the both types the output is amplified.

Some of the direct measurement instruments are

1. Stylus probe instruments.
2. Tomlinson surface meter.
3. Profilometer.
4. Taylor-Hobson Talysurf

1. Stylus probe type instrument

Principle

When the stylus is moved over the surface which is to be measured, the irregularities in the surface texture are measured and it is used to assess the surface finish of the work piece.

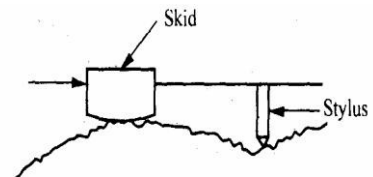

Working

The stylus type instruments consist of skid, stylus, amplifying device and recording device. The skid is slowly moved over the surface by hand or by motor drive. The skid follows the irregularities of the surface and the stylus moves along with skid. When the stylus moves vertically up and down and the stylus movements

are magnified, amplified and recorded to produce a trace. Then it is analyzed by automatic device.

Advantage

Any desired roughness parameter can be recorded.

Disadvantages

1. Fragile material cannot be measured.
2. High Initial cost.
3. Skilled operators are needed to operate.

2. Tomlinson Surface meter

This instrument uses mechanical-cum-optical means for magnification.

Construction

In this the diamond stylus on the surface finish recorder is held by spring pressure against the surface of a lapped cylinder. The lapped cylinder is supported one side by probe and other side by rollers. The stylus is also attached to the body of the instrument by a leaf spring and its height is adjustable to enable the diamond to be positioned and the light spring steel arm is attached to the lapped cylinder. The spring arm has a diamond scribe at the end and smoked glass is rest

on the arm.

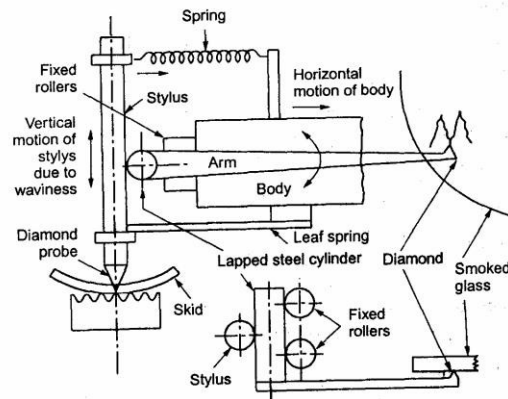

Fig 3.24 Tomlinson Surface meter

Working

Fig 3.25 Profilometer

When measuring surface finish the body of the instrument is moved across the surface by a screw rotation. The vertical movement of the probe caused by the surface irregularities makes the horizontal lapped cylinder to roll. This rolling of lapped cylinder causes the movement of the arm. So this movement induces the diamond scribe on smoked glass. Finally the movement of scribe together with horizontal movement produces a trace on the smoked glass plate and this trace is magnified by an optical projector.

3. Profilometer

It is an indicating and recording instrument to measure roughness in microns. The main parts of the instrument are tracer and an amplifier. The stylus is mounted in the pickup and it consists of induction coil

located in the magnet. When the stylus is moved on the surface to be tested, it is displaced up and down

due to irregularities in the surface. This movement induces the induction coil to move in the direction of permanent magnet and produces a voltage. This is amplified and recorded.

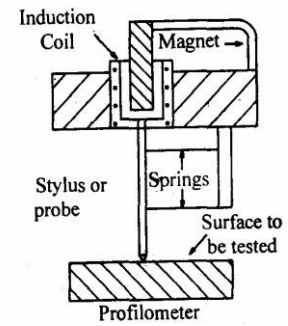

4. Talyor-Hobson-Talysurf

It is working a carrier modulating principle and it is an accurate method comparing with the other methods. The main parts of this instrument is diamond stylus (0.002mm radius) and skid

Principle

The irregularities of the surface are traced by the stylus and the movement of the stylus is converted into changes in electric current.

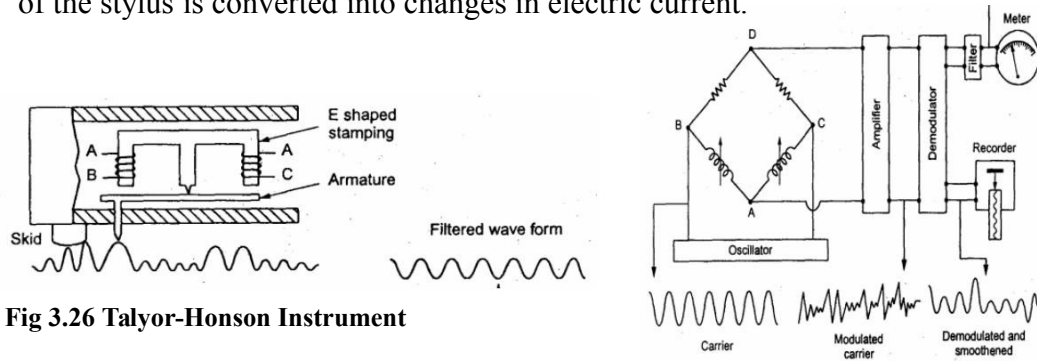

Fig 3.26 Talyor-Honson Instrument

Working

On two legs of the E-shaped stamping there are coils for carrying an A.C. current and these coils form an oscillator. As the armature is pivoted about the central leg the movement of the stylus causes the air gap to vary and thus the amplitude is modulated. This modulation is again demodulated for the vertical displacement of the stylus. So this demodulated output is moved to the pen recorder to produce a numerical record and to make a direct numerical assessment.

3.6 STRAIGHTNESS MEASUREMENT

A line is said to be straight over a given length, if the variation of the distance of its from two planes perpendicular to each other and parallel to the general direction of the line remains within the specified tolerance limits. The tolerance on the straightness of a line is defined as the maximum deviation in relation to the reference straight line joining the two extremities of the line to be checked.

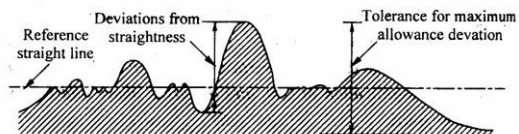

Fig 3.27 Straightness Measurement

3.6.1 Straight edge

A straight edge is a measuring tool which consists of a length of a steel of narrow and deep section in order to provide resistance to bending in the plane of measurement without excessive weight. For checking the straightness of any surface, the straight edge is placed over the surface and two are viewed against the light, which clearly indicate the straightness. The gap between the straight edge and surface will be negligibly small for perfect surfaces. Straightness is measured by observing the colour of light by diffraction while passing through the small gap. If the colour of light be red, it indicates a gap of 0.0012 to 0.0075mm. A more accurate method of finding the straightness by straight edges is to place it in equal slip gauges at the correct point for minimum deflection and to measure the uniformity of space under the straight edge with slip gauges.

3.6.2 Test for straightness by using spirit level and Autocollimator

The straightness of any surface could be determined by either of these instruments by measuring the relative angular positions of number of adjacent sections of the surface to be tested. First straight line is drawn on the surface then it is divided into a number of sections the length of each section being equal to the length of spirit level base or the plane reflector's base in case of auto collimator. The bases of the spirit level block or reflector are fitted with two feet so that only feet have line contact with the surface and the surface of base does not touch the surface to be tested. The angular division obtained is between the specified two points. Length of each section must be equal to distance between the centerlines of two feet. The special level can be used only for the measurement of straightness of horizontal surfaces while auto-collimator can be used on surfaces are any plane. In case of spirit level, the block is moved along the line equal to the pitch distance between the centerline of the feet and the angular variation of the direction of block. Angular variation can be determined in terms of the difference of height between two points by knowing the least count of level and length of the base.

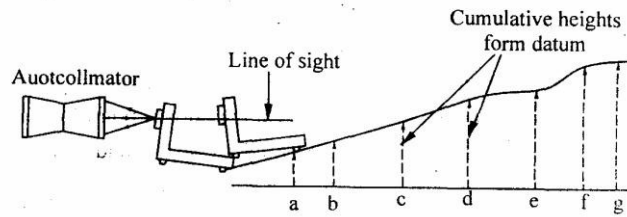

Fig 3.28 Straightness using Auto-Collimator

In case of autocollimator the instrument is placed at a distance of 0.5 to 0.75m from the surface to be tested. The parallel beam from the instrument is projected along the length of the surface to be tested. A block fixed on two feet and fitted with a plane vertical reflector is placed on the surface and the reflector face is facing the instrument. The image of the cross wires of the collimator appears nearer the center of the field and for the complete movement of reflector along the surface straight line the image of cross wires will appear in the field of eyepiece. The reflector is then moved to the other end of the surface in steps equal to. The center distance between the feet and the tilt of the reflector is noted down in second from the eyepiece.

3.7 FLATNESS TESTING

Flatness testing is possible by comparing the surface with an accurate surface. This method is suitable for small plates and not for large surfaces. Mathematically flatness error of a surface states that the departure from flatness is the minimum separation of a pair of parallel planes which will contain all points on the surface. The figure which shows that a surface can be considered to be composed of an infinitely large number of lines. The surface will be flat only if all the lines are straight and they lie in the same plane. In the case of rectangular table the lines are straight and parallel to the sides of the rectangle in both the perpendicular direction. Even it is not flat, but concave and convex along two diagonals. For verification, it is essential to measure the straightness of diagonals in addition to the lines parallel to the sides.

Thus the whole of the surface is divided by straight line. The fig. shows the surface is divided by straight line. The end line AB and AD etc are drawn away from the edges as the edges of the surface are not flat but get worn out by use and can fall off little in accuracy. The straightness of all these lines is determined and then those lines are

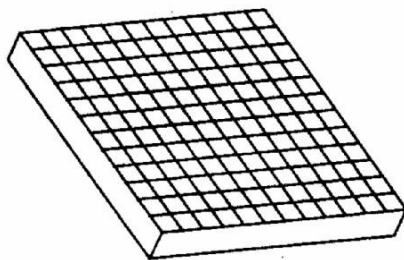

related
each
in order
verify
whether

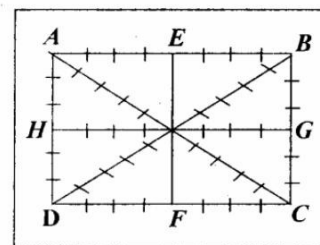

with
other
to
they

lie in the same plane or not.

3.7.1 Procedure for determining flatness

The fig. shows the flatness testing procedure.

- (i) Carry out the straightness test and tabulate the reading up to the cumulative error column.
- (ii) Ends of lines AB, AD and BD are corrected to zero and thus the height of the points A, B and D are zero.

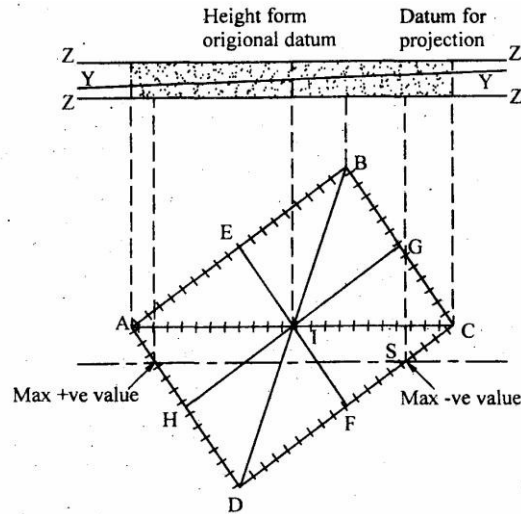

Fig 3.29 Flatness Test

The height of the point I is determined relative to the arbitrary plane $ABD = 000$. Point C is now fixed relative to the arbitrary plane and points B and D are set at zero, all intermediate points on BC and DC can be corrected accordingly. The positions of H and G, E and F are known, so it is now possible to fit in lines HG and EF. This also provides a check on previous evaluations since the mid-point of these lines should coincide with the position of mid-point I. In this way, the height of all the points on the surface relative to the arbitrary plane ABD is known.

3.8 ROUNDNESS MEASUREMENTS

Roundness is defined as a condition of a surface of revolution. Where all points of the surface intersected by any plane perpendicular to a common axis in case of cylinder and cone.

3.8.1 Devices used for measurement of roundness

- 1) Diametral gauge.
- 2) Circumferential conferring gauge => a shaft is confined in a ring gauge and rotated against a set indicator probe.
- 3) Rotating on center
- 4) V-Block

- 5) Three-point probe.
- 6) Accurate spindle.

1. Diametral method

The measuring plungers are located 180° apart and the diameter is measured at several places. This method is suitable only when the specimen is elliptical or has an even number of lobes. Diametral check does not necessarily disclose effective size or roundness. This method is unreliable in determining roundness.

2. Circumferential confining gauge

Fig. shows the principle of this method. It is useful for inspection of roundness in production. This method requires highly accurate master for each size part to be measured. The clearance between part and gauge is critical to reliability. This technique does not allow for the measurement of other related geometric characteristics, such as concentricity, flatness of shoulders etc.

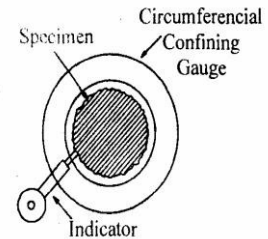

Fig 3.30 Confining Gauge

3. Rotating on centers

The shaft is inspected for roundness while mounted on center. In this case, reliability is dependent on any factors like angle of centers, alignment of centres, roundness and surface condition of the centres and centre holes and run out of piece. Out of straightness of the part will cause a doubling run out effect and appear to be roundness error.

Fig 3.31 V-Block

4. V-Block

The set up employed for assessing the circularity error by using V Block is shown in fig.

The V block is placed on surface plate and the work to be checked is placed upon it. A diameter indicator is fixed in a stand and its feeler made to rest against the surface of the work. The work is rotated to measure the rise on fall of the work piece. For determining the number of lobes on the work piece, the work piece is first tested in a 60° V-Block and then in a 90° V-Block. The number of lobes is then equal to the number of times the indicator pointer deflects through 360° rotation of the work piece.

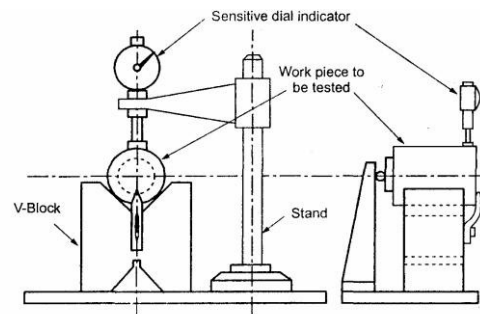

Limitations

- a) The circularity error is greatly affected by the following factors.
 - (i) If the circularity error is small, then it is possible that the indicator shows no variation.
 - (ii) Position of the instrument i.e. whether measured from top or bottom.
 - (iii) Number of lobes on the rotating part.
- b) The instrument position should be in the same vertical plane as the point of contact of the part with the V-block.

c) A leaf spring should always be kept below the indicator plunger and the surface of the part



5. Three point probe

The fig. shows three probes with 120° spacing is very, useful for determining effective size they perform like a 60° V-block. 60° V-block will show no error for 5 a 7 lobes magnify the error for 3-lobed parts show partial error for randomly spaced lobes.

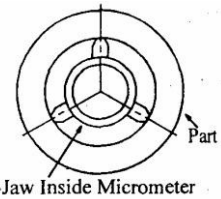

Fig 3.32 Three Point Probe

3.8.2 Roundness measuring spindle

There are following two types of spindles used.

1. Overhead spindle

Part is fixed in a staging plat form a d the overhead spindle carrying the comparator rotates separately from the p rt. It c determi e roundness as well as camming (Circular flatness). Height of the work piece is limited by the location of overhead spindle. The concentricity can be c ecked by extending the indicator from the spindle and thus the range of this check is limited.

2. Rotating table

Spindle is integral with the table and rotates along with it. The part is placed over the spindle and rotates past a fixed co parator

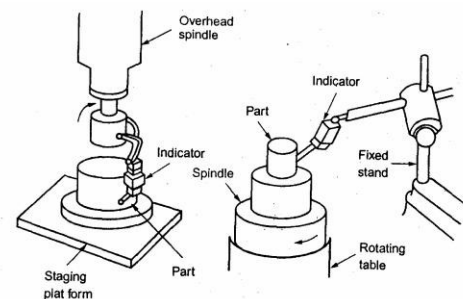

Fig 3.32 Rotating Table

3.8.3 Roundness measuring machine

Roundness is the property of a surface of revolution, where all points on the surface are equidistant from the axis. The roundness of any profile can be specified only hen same center is found from which to make the measurements. The diameter and

roundness are measured by different method and instruments. For measurement of diameter it is done statically, for measuring roundness, rotation is always necessary.

Roundness measuring instruments are two types.

1. Rotating pickup type.
2. Turn table type.

These are accurate, speed and reliable measurements. The rotating pickup type the work piece is stationary and the pickup revolved. In the turn table the work piece is rotated and pickup is stationary. On the rotating type, spindle is designed to carry the light load of the pickup. The weight of the work piece, being stationary and is easy to make. In the turn table type the pickup is not associated with the spindle. This is easier to measure roundness. Reposition the pickup has no effects on the reference axis.

The pickup converts the circuit movement of the stylus into electrical signal, which is processed and amplified and fed to polar recorder. A microcomputer is incorporated with integral visual display unit and system is controlled from compact keyboards, which increases the system versatility, scope and speed of analysis. System is programmed to access the roundness of work piece with respect to any four of the internationality recognized reference circles. A visual display of work piece profile can be obtained. Work piece can be assessed over a circumference, and with undercut surface or an interrupted surface with sufficient data the reference circle can be fitted to the profile. The program also provides functions like auto centering, auto ranging, auto calibration and concentricity.

3.8.4 Modern Roundness Measuring Instruments

This is based on use of microprocessor to provide measurements of roundness quickly and in a simple way; there is no need of assessing out of roundness. Machine can do centering automatically and calculate roundness and concentricity, straightness and provide visual and digital displays. A computer is used to speed up calculations and provide the standard reference circle.

(i) Least square circle

The sum of the squares of a sufficient no. of equally spaced radial ordinates measured from the circle to the profile has minimum value. The center of such circle is referred to as the least square center. Out of roundness is defined as the radial distance of the maximum peak from the circle (P) plus the distance of the maximum valley from this circle.

(ii) Minimum zone or Minimum radial separation circle

These are two concentric circles. The value of the out of roundness is the radial distance between the two circles. The center of such a circle is termed as the minimum zone center. These circles can be found by using a template.

(iii) Maximum inscribed circle

This is the largest circle. Its center and radius can be found by trial and error by compare or by template or computer. Since $V = 0$ there is no valleys inside the circle.

(iv) Minimum circumscribed circles

This is the smallest circle. Its center and radius can be found by the previous method since $P = 0$ there is no peak outside the circle. The radial distance between the minimum circumscribing circle and the maximum inscribing circle is the measure of the error circularity. The fig shows the trace produced by a recording instrument.

This trace to draw concentric circles on the polar graph which pass through the maximum and minimum points in such way that the radial distance between minimum circumscribing circle containing the trace or the maximum inscribing circle which can be fitted into the trace is minimum. The radial distance between the outer and inner circle is minimum is considered for determining the circularity error. Assessment of roundness can be done by templates. The out of roundness is defined as the radial distance of the maximum peak (P) from the least square circle plus the distance of the maximum valley (V) from

the least square circle. All roundness analysis can be performed by harmonic and slope analysis.



QUESTION BANK

Part-A (2 Marks)

1. Name the various methods for measuring effective diameter
2. Name the various methods for measuring pitch diameter.
3. Name the two corrections are to be applied in the measurement of effective di meter.
4. What is best size of wire?
5. Define. Drunken thread
6. What is the effect of flank angle error?
7. What are the applications of toolmaker's microscope?
8. Define: Periodic error.
9. What are the commonly used forms of gear teeth?
10. What are the types of gears?
11. Define: Module
12. Define: Lead angle
13. What are the various methods used for measuring the gear tooth thickness?
14. Name four gear errors.
15. Name the method used for ch cking the pitch of the gear.

Part-B (16 Marks)

1. Explain the construction and working of floating carriage micrometer
 2. How are the major and inor dia eters of thread measured?
 3. Define various terminologies related with screw thread
 4. Define various terminologies related with screw gears
 5. Explain any t o taper measurements method.
 6. Explain the construction and working of Gear tooth vernier
 7. Explain a method used in the measurement of surface finish and flatness
 8. How to measure the pitch of the screw thread by using the tool maker's microscope?
Discuss in detail.
-

9. Describe the method of inspecting the profile of spur gear by using involute measuring machine.
 10. How to check the composite errors of the gear by using Parkinson gear testing machine? Explain it in detail?
 11. Briefly describe major, minor and effective diameter of thread?
 12. Describe the two wire method of finding the effective diameter of screw threads.
 13. Describe the chordal thickness method using gear tooth vernier caliper.
 14. Explain one method of assessing the straightness of a straight-edge.
 15. Write notes on the types of irregularities of a circular part and mention its causes.
 16. What is the 'best wire size'? Derive an expression for the same in terms of the pitch and angle of the thread,
 17. Explain the principle of measuring gear tooth thickness by base tangent method. What is the span length over 5 teeth of gear having 45 teeth module 4mm and pressure angle 20°
 18. Derive the formula for measuring the effective diameter of thread by 3-wire method
 19. With the aid of sketch describe the principle of operation of a rolling gear testing machine.
-

MODULE-IV
LASER METROLOGY



CONTENTS

- 4.1 PRECISION INSTRUMENT BASED ON LASER
 - 4.1.1 Laser Metrology
 - 4.1.2 Use of Laser
 - 4.1.3 Principle of Laser
 - 4.2 LASER INTERFEROMETRY
 - 4.3 LASER INTERFEROMETER
 - 4.3.1 Michelson Interferometer
 - 4.3.2 Dual Frequency Laser Interferometer
 - 4.3.3 Twyman-Green Interferometer
 - 4.3.4 Laser Viewers
 - 4.4 INTERFEROMETRIC MEASUREMENT OF ANGLE
 - 4.5 MACHINE TOOL TESTING
 - 4.6 CO-ORDINATE MEASURING MACHINES
 - 4.6.1 Types of Measuring Machines
 - 4.6.2 Constructions of CMM
 - 4.6.3 Types of CMM
 - 4.6.4 Causes of Errors in CMM
 - 4.6.5 Calibration of Three Co-Ordinate Measuring Machine
 - 4.7 APPLICATIONS
 - 4.8 COMPUTER CONTROLLED CO-ORDINATE MEASURING MACHINE
 - 4.8.1 Trigger type probe system
 - 4.8.2 Measuring type probe system
 - 4.9 CNC-CMM
 - 4.10 COMPUTER AIDED INSPECTION USING ROBOTS
 - 4.10.1 Integration of CAD/CAM with Inspection System
 - 4.10.2 Flexible Inspection System
-

4.10.3 Machine Vision

4.10.4 Vision System

4.10.5 Function of Machine Vision

4.10.6 Applications



TECHNICAL TERMS

□ **Interferometer**

Interferometer is optical instruments used for measuring flatness and determining the lengths of slip gauges by direct reference to the wavelength of light.

□ **Machine Vision**

Machine vision can be defined as a means of simulating the image recognition and analysis capabilities of the human system with electronic and electromechanical techniques.

□ **Inspection**

It is the ability of an automated vision system to recognize well-defined pattern and if these pattern match those stored in the system makes machine vision ideal for inspection of raw materials, parts, assemblies etc.

□ **CMM**

It is a three dimensional measurement for various components. These machines have precise movement in x,y,z coordinates which can be easily controlled and measured. Each slide in three directions is equipped with a precision linear measurement transducer which gives digital display and senses positive and negative direction.

□ **Axial Length Measuring Accuracy**

It is defined as difference between the reference length of gauges aligned with a machine axis and the corresponding measurement results from the machine.



4.1 PRECISION INSTRUMENT BASED ON LASER

Laser stands for **Light Amplification by Stimulated Emission of Radiation**. Laser instrument is a device to produce powerful, monochromatic, collimated beam of light in which the **waves are coherent**. Laser development is for production of clear coherent light. The advantage of coherent light is that whole of the energy appears to be emanating from a very small point. The beam can be focused easily into either a parallel beam or onto a very small point by use of lenses. A major impact on optical measurement has been made by development in electrodynamics, providing automation, greater acuity of setting and faster response time. Radiation sources have developed in a number of areas; the most important developments are light emitting diodes and lasers. The laser is used extensively for interferometry particularly the He-Ne gas type. The laser distance measuring interferometer has become an industry standard. This produces 1 to 2mm diameter beam of red light power of 1mW and focused at a point of very high intensity. The beam begins to expand at a rate of 1mm/m. The laser beam is visible and it can be observed easily. This is used for very accurate measurements of the order of 0.1µm to 100µm.

4.1.1 Laser Metrology

Metrology lasers are low power instruments. Most are helium-neon type. Wave output laser that emit visible or infrared light. He-Ne lasers produce light at a wavelength of 0.63µm that is in phase, coherent and a thousand times more intense than any other monochromatic source. Laser systems have wide dynamic range, low optical cross talk and high contrast. Laser find application in dimensional measurements and surface inspection because of the properties of laser light. These are useful where precision, accuracy, rapid non-contact gauging of soft, delicate or hot moving points.

4.1.2 Use of Laser

□ Laser Telemetric system

Laser telemetric system is a non-contact gauge that measures with collimated laser beam. It measures at the rate of 150 scans per second. It basically consists of three components, a transmitter, a receiver and processor electronics. The transmitter module produces a collimated parallel scanning laser beam moving at a high constant, linear speed. The scanning beam appears a red line. The receiver module collects and photoelectrically senses the laser light transmitted past the object being measured. The processor electronics takes the received signals to convert them to a convenient form and displays the dimension being gauged. The transmitter contains a low power helium-neon gas laser and its power supply, a specially designed collimating lens, a synchronous motor, a multi faceted reflector prism, a synchronous pulse photo detector and a protective replaceable window. The high speed of scanning permits on line gauging and thus it is possible to detect changes in dimensions when components are moving on a continuous product such as in rolling process moving at very high speed. There is no need of waiting for product to cool for taking measurements. This system can also be applied on production machines and control them with closed feedback loops. Since the output of this system is available in digital form, it can run a process controller limit alarms can be provided and output can be taken on digital printer.

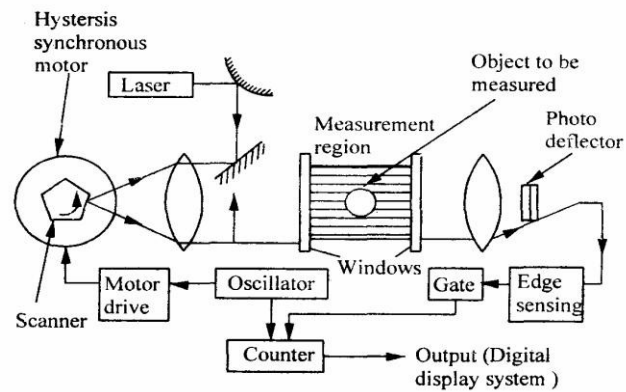
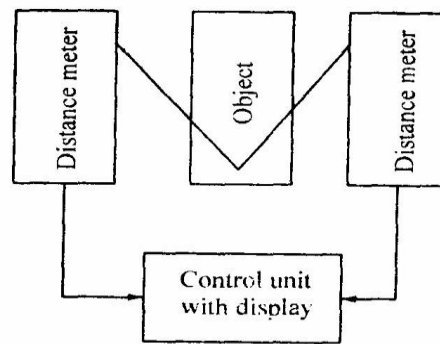

Fig 4.1 Laser Telemetric System

□ **Laser and LED based distance measuring instruments**

These can measure distances from 1 to 2in with accuracy of the order of 0.1 to 1% of the measuring range. When the light emitted by laser or LED hits an object, scatter and some of this scattered light is seen by a position sensitive detector or diode array. If the distance between the measuring head and the object changes, the angle at which the light enters the detector will also change. The angle of deviation is calibrated in terms of distance and output is provided as 0-20mA. Such instruments are very reliable because there are no moving parts their response time is milliseconds. The measuring system uses two distance meters placed at equal distance on either side of the object and a control unit to measure the thickness of an object. The distance meter is focused at the centre of the object.





□ Scanning Laser gauge

Fig shows a schematic diagram of a scanning laser gauge. It consists of transmitter, receiver and processor electronics. A thin band of scanning laser light is made to pass through a linear scanner lens to render it parallel beam. The object placed in a parallel beam, casts a time dependent shadow. Signal from the light entering the photocell (receiver) are processed by a microprocessor to provide display of the dimension represented by the time difference between the shadow edges. It can provide results to an accuracy of 0.25 for 10—50mm diameter objects. It can be used for objects 0.05mm to 450mm diameter; and offers repeatability of 0.1μm

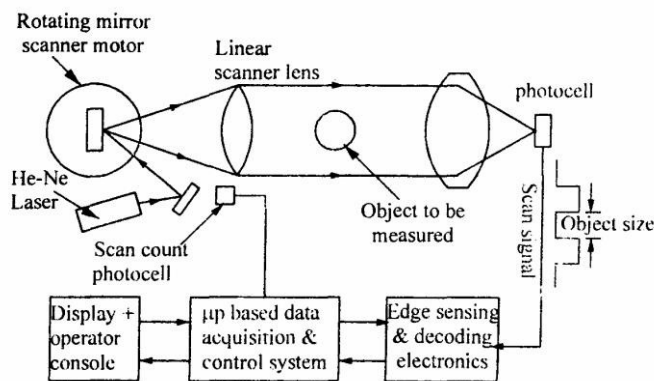

Fig 4.2 Scanning Laser Gauge

□ Photo diode array imaging

The system comprises of laser source, imaging optics, Photo-diode array, Signal processor and display unit. For large parts, two arrays in which one for each edge are used. Accuracies as high as 0.05 μm have been achieved.

□ **Diffraction pattern technique**

These are used to measure small gaps and small diameter parts. A parallel coherent laser beam is diffracted by a small part and a lens on a linear diode array focuses the resultant pattern. Its use is restricted to small wires. The measurement accuracy is more for smaller parts. The distance between the alternating light and dark bands in the diffraction pattern is a (tired function of the wire diameter, wavelength of laser beam and the focal length of the lens.

□ **Two- frequency laser interferometer**

Fig. shows schematic arrangement. This consists of two frequency laser head, beam directing and splitting optics, measurement optics, receivers, and wavelength compensators and electronics. It is ideally suited for measuring linear positioning straightness in two planes, pitch and yaw.

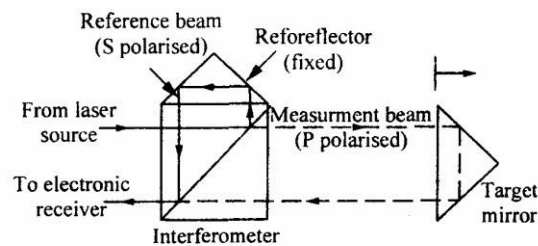

Fig 4.3 Two-frequency laser interferometer

The two-frequency laser head provides one frequency with P-polarization and another frequency with S-polarization. The laser beam is split at the polarizing beam splitter into its two separate frequencies. The measuring beam is directed through the interferometer to reflect off a target mirror or retro reflector attached to the object to be measured. The reference beam is reflected from fixed retro reflector. The measurement beam on its return path recombines with the reference beam and is directed to the electronic receiver.

□ **Gauging wide diameter from the diffraction pattern formed in a laser**

Figure shows a method of measuring the diameter of thin wire using the interference fringes resulting from diffraction of the light by the wire in the laser beam. A measure of the diameter can be obtained by moving the photo detector until the output is restored to its original value. Variation in wire diameter as small as 0.2% over wire diameter from 0.005 to 0.2mm can be measured.

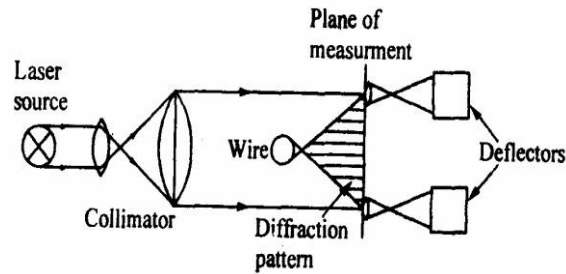

Fig 4.4 Diffraction Pattern

Figure shows the length measurement by fringe counting. The laser output, which may be incoherent illuminates three slits at a time in the first plane which form interference fringes. The movement can be determined by a detector. The total number of slits in the first plane is governed by the length over which measurement is required.

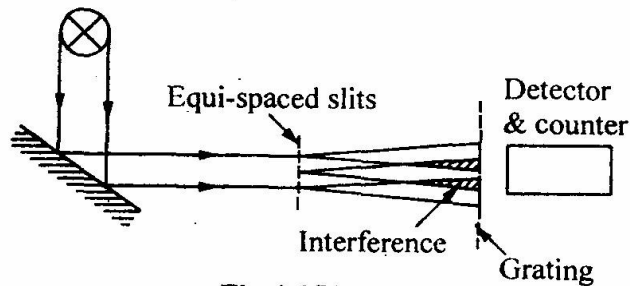

Fig 4.5 Fringe counting

The spacing between the slits and distance of the slit to the plane of the grating depend on the wavelength of the light used.

4.1.3 Principle of Laser

The photon emitted during stimulated emission has the same energy, phase and frequency as the incident photon. This principle states that the photon comes in contact with another atom or molecule in the higher energy level E_2 then it will cause the atom to

return to ground state energy level E_1 by releasing another photon. The sequence of triggered identical photon from stimulated atom is known as stimulated emission. This multiplication of photon through stimulated emission leads to coherent, powerful, monochromatic, collimated beam of light emission. This light emission is called laser

4.2 LASER INTERFEROMETRY

Brief Description of components

(i) Two frequency Laser source

It is generally He-Ne type that generates stable coherent light beam of two frequencies, one polarized vertically and another horizontally relative to the plane of the mounting feet. Laser oscillates at two slightly different frequencies by a cylindrical permanent magnet around the cavity. The two components of frequencies are distinguishable by their opposite circular polarization. Beam containing both frequencies passes through a quarter wave and half wave plates which change the circular polarizations to linear perpendicular polarizations, one vertical and other horizontal. Thus the laser can be rotated by 90° about the beam axis without affecting transducer performance. If the laser source is deviated from one of the four optimum positions, the photo receiver will decrease. At 45° deviation the signal will decrease to zero.

(ii) Optical elements

a) Beam splitter

Sketch shows the beam splitters to divide laser output along different axes. These divide the laser beam into separate beams. To avoid attenuation it is essential that the beam splitters must be oriented so that the reflected beam forms a right angle with the transmitted beam. So that these two beams: are coplanar with one of the polarisation vectors of the input form.

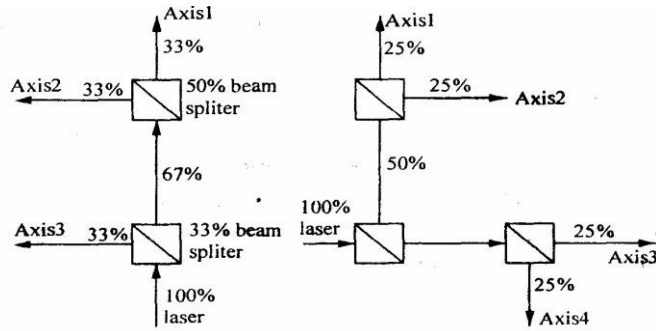

Fig 4.6 Beam Splitter

b) Beam benders

These are used to deflect the light beam around corners on its path from the laser to each axis. These are actually just flat mirrors but having absolutely flat and very high reflectivity. Normally these are restricted to 90° beam deflections to avoid disturbing the polarizing vectors.

c) Retro reflectors

These can be plane mirrors, roof prism or cube corners. Cube corners are three mutually perpendicular plane mirrors and the reflected beam is always parallel to the incident beam. Each ACLI transducer needs two retro reflectors. All ACLI measurements are made by using differential motion between two retro reflectors relative to an interferometer. Plane mirrors used as retro reflectors with the plane mirror interferometer must be flat to within 0.06 micron per cm.

(iii) Laser head's measurement receiver

During a measurement the laser beam is directed through optics in the measurement path and then returned to the laser head is measurement receiver which will detect part of the returning beam and a doppler shifted frequency component.

(iv) Measurement display

It contains a microcomputer to compute and display results. The signals from receiver and measurement receiver located in the laser head are counted in two separate

pulse converter and subtracted. Calculations are made and the computed value is displayed. Other input signals for correction are temperature, co-efficient of expansion, air velocity etc., which can be displayed.

(v) Various version of ACLI

a) Standard Interferometer

- Least expensive.
- Retro reflector for this instrument is a cube corner.
- Displacement is measured between the interferometer and cube corner.

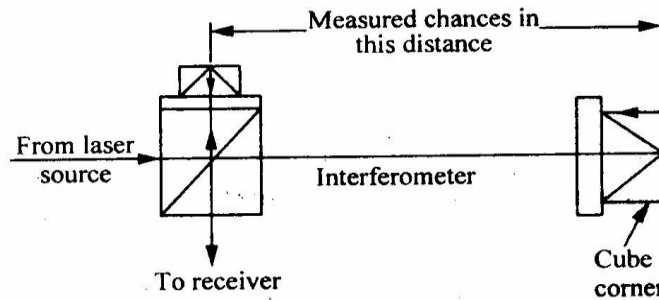

Fig 4.7 Standard Interferometer

b) Signal beams Interferometer

- Beam traveling between the interferometer and the retro reflector.
- Its operation same as standard interferometer.
- The interferometer and retro reflector for this system are smaller than the standard system.
- Long range optical path
- Wear and tear.

4.3 LASER INTERFEROMETER

It is possible to maintain the quality of interference fringes over longer distance when lamp is replaced by a laser source. Laser interferometer uses AC laser as the light source and the measurements to be made over longer distance. Laser is a monochromatic

optical energy, which can be collimated into a directional beam AC. Laser interferometer (ACLI) has the following advantages.

- High repeatability
- High accuracy
- Long range optical path
- Easy installations
- Wear and tear

Schematic arrangement of laser interferometer is shown in fig. Two-frequency zeeman laser generates light of two slightly different frequencies with opposite circular polarisation. These beams get split up by beam splitter B. One part travels towards B and from there to external cube corner here the displacement is to be measured.

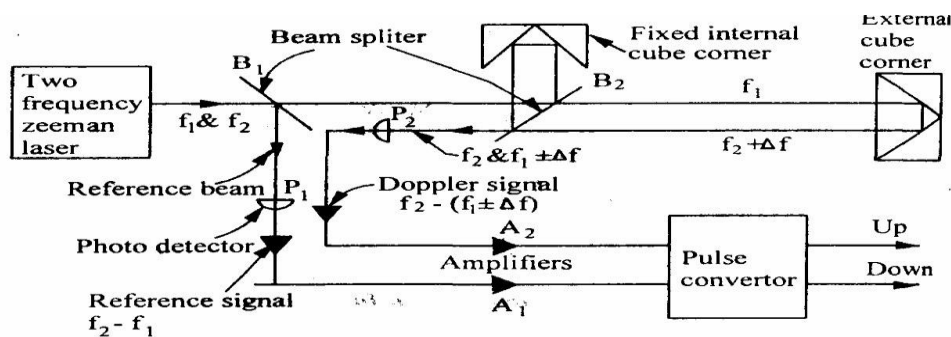

Fig 4.8 Laser Interferometer

This interferometer uses cube corner reflectors which reflect light parallel to its angle of incidence. Beam splitter B2 optically separates the frequency f_1 which alone is sent to the movable cube corner reflector. The second frequency from B2 is sent to a fixed reflector which then rejoins f_1 at the beam splitter B2 to produce alternate light and dark interference flicker at about 2 Mega cycles per second. Now if the movable reflector moves, then the returning beam frequency is Doppler-shifted slightly up or down by Δf . Thus the light beams moving towards photo detector P2 have frequencies f_2 and $(f_1 \pm \Delta f)$ and P2 changes these frequencies into electrical signal. Photo detector P2 receives signal from beam splitter B2 and changes the reference beam frequencies f_1 and f_2 into

electrical signal. An AC amplifier A separates frequency. Difference signal $f_2 - f_1$ and A2 separates frequency difference signal. The pulse converter extracts i. one cycle per half wavelength of motion. The up-down pulses are counted electronically and displayed in analog or digital form.

4.3.1 Michelson Interferometer

Michelson interferometer consists of a monochromatic light source, a beam splitter, and two mirrors. The schematic arrangement of Michelson interferometer is shown in fig. The monochromatic light falls on a beam splitter, which splits the light into two rays of equal intensity at right angles. One ray is transmitted to mirror M1 and other is reflected through beam splitter to mirror M2. From both these mirrors, the rays are reflected back and these return at the semireflecting surface from where they are transmitted to the eye. Mirror M2 is fixed and mirror M1 is movable. If both the mirrors are at same distance from beam splitter, then light will arrive in phase and observer will see bright spot due to constructive interference. If movable mirror shifts by quarter wavelength, then beam will return to observer 180° out of phase and darkness will be observed due to destructive interference.

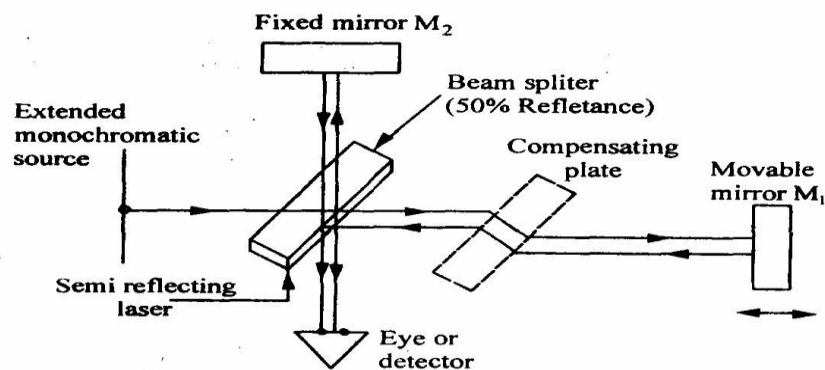

Fig 4.9 Michelson Interferometer

Each half-wave length of mirror travel produces a change in the measured optical path of one wavelength and the reflected beam from the moving mirror shifts through 360° phase change. When the reference beam reflected from the fixed mirror and the

beam reflected from the moving mirror rejoin at the beam splitter, they alternately reinforce and cancel each other as the mirror moves. Each cycle of intensity at the eye represents $1/2$ of mirror travel. When white light source is used then a compensator plate is introduced in each of the path of mirror M1 So that exactly the same amount of glass is introduced in each of the path.

To improve the Michelson interferometer

- (i) Use of laser the measurements can be made over longer distances and highly accurate measurements when compared to other monochromatic sources.
- (ii) Mirrors are replaced by cube-corner reflector which reflects light parallel to its angle of incidence.
- (iii) Photocells are employed which convert light intensity variation in voltage pulses to give the amount and direction of position change.

4.3.2 Dual Frequency Laser Interferometer

This instrument is used to measure displacement, high-precision measurements of length, angle, speeds and refractive indices as well as derived static and dynamic quantities. This system can be used for both incremental displacement and angle measurements. Due to large counting range it is possible to attain a resolution of 2nm in 10m measuring range. Means are also provided to compensate for the influence of ambient temperature, material temperature, atmospheric pressure and humidity fluctuation

4.3.3 Twyman-Green Interferometer

The Twyman-Green interferometer is used as a polarizing interferometer with variable amplitude balancing between sample and reference waves. For an exact measurement of the test surface, the instrument error can be determined by an absolute measurement. This error is compensated by storing the same in microprocessor system and subtracting from the measurement of the test surface.

It has following advantages

- It permits testing of surface with wide varying reflectivity.
- It avoids undesirable feedback of light reflected of the tested surface and the instrument optics.
- It enables utilization of the maximum available energy.
- Polarization permits phase variation to be effected with the necessary precision.

4.3.4 Laser Viewers

The profile of complex components like turbine blades can be checked by the use of optical techniques. It is based on use of laser and CCTV. A section of the blade, around its edge is delineated by two flat beams of laser light. This part of the edge is viewed at a narrow angle by the TV camera or beam splitter

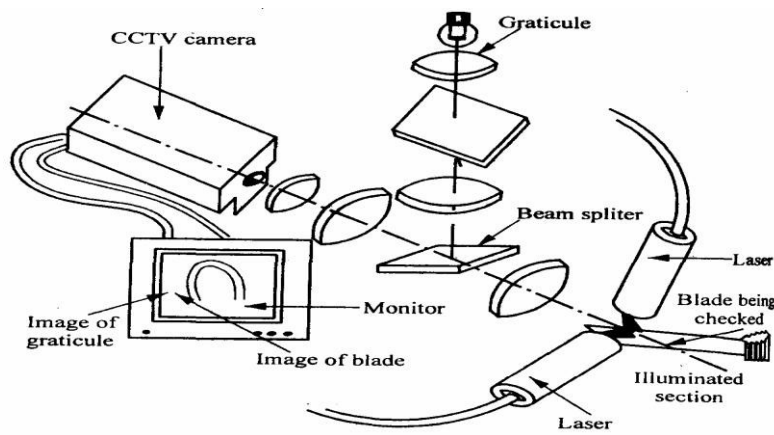

Fig 4.10 Laser Viewers

Both blade and graticule are displayed as magnified images on the monitor, the graticule position being adjustable so that its image can be superimposed on the profile image. The graticule is effectively viewed at the same angle as the blade. So, distortion due to viewing angle affects both blade and graticule. This means that the graticule images are direct 1:1.

4.4 INTERFEROMETRIC MEASUREMENT OF ANGLE

With laser interferometer it is possible to measure length to accuracy of 1 part in 10⁶ on a routine basis. With the help of two retro reflectors placed at a fixed distance and a length measuring laser interferometer the change in angle can be measured to an accuracy of 0.1 second. The device uses sine Principle. The line joining the poles the retro-reflectors makes the hypotenuse of the right triangle. The change in the path difference of the reflected beam represents the side of the triangle opposite to the angle being measured. Such laser interferometer can be used to measure an angle up to ± 10 degrees with a resolution of 0.1 second. The principle of operation is shown in fig.

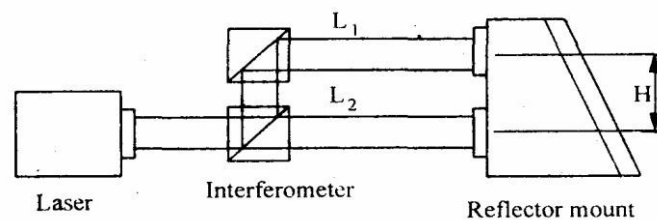

Fig 4.11 Interferometric Angle Measurement

4.4.1 Laser Equipment for Alignment Testing

This testing is particularly suitable in aircraft production, shipbuilding etc. Where a number of components, spaced long distance apart, have to be checked to a predetermined straight line. Other uses of laser equipment are testing of flatness of machined surfaces, checking squareness with the help of optical square etc. These consist of laser tube which produces a cylindrical beam of laser about 10mm diameter and an auto reflector with a high degree of accuracy. Laser tube consists of helium-neon plasma tube in a heat aluminum cylindrical housing. The laser beam comes out of the housing from its centre and parallel to the housing within 10'' of arc and alignment stability is the order of 0.2'' of arc per hour. Auto reflector consists of detector head and read out unit. Number of photocells are arranged to compare laser beam in each half horizontally and vertically. This is housed on a stand which has two adjustments to

translate the detector in its two orthogonal measuring directions perpendicular to the laser beam. The devices detect the alignment of flat surfaces perpendicular to a reference line of sight.

4.5 MACHINE TOOL TESTING

The accuracy of manufactured parts depends on the accuracy of machine tools. The quality of work piece depends on Rigidity and stiffness of machine tool and its components. Alignment of various components in relation to one another Quality and accuracy of driving mechanism and control devices. It can be classified into

- Static tests
- Dynamic tests.

□ **Static tests**

If the alignment of the components of the machine tool are checked under static conditions then the test are called static test.

□ **Dynamic tests**

If the alignment tests are carried out under dynamic loading condition. The accuracy of machine tools which cut metal by removing chips is tested by two types of test namely.

- o Geometrical tests
- o Practical tests

□ **Geometrical tests**

In this test, dimensions of components, position of components and displacement of component relative to one another is checked.

□ **Practical tests**

In these test, test pieces are machined in the machines. The test pieces must be appropriate to the fundamental purpose for which the machine has been designed.

4.5.1 Purpose of Machine Tool Testing

The dimensions of any work piece, its surface finishes and geometry depends on the accuracy of machine tool for its manufacture. In mass production the various components produced should be of high accuracy to be assembled on a non-sensitive basis. The increasing demand for accurately machined components has led to improvement of geometric accuracy of machine tools. For this purpose various checks on different components of the machine tool are carried out.

4.5.2 Type of Geometrical Checks on Machine Tools.

Different types of geometrical tests conducted on machine tools are as follows:

1. Straightness.
2. Flatness.
3. Parallelism, equi-distance and coincidence.
4. Rectilinear movements or squareness of straight line and plane.
5. Rotations.
 - 1) Out of round.
 - 2) Eccentricity
 - 3) Radial-throw of an axis.
 - 4) Run out
 - 5) Periodical axial slip
 - 6) Chasing

4.5.3 Various tests conducted on any Machine Tools

- Test for level of installation of machine tool in horizontal and vertical planes.
 - Test for flatness of machine bed and for straightness and parallelism of bed ways on bearing surface.
 - Test for perpendicularity of guide ways to other guide ways.
 - Test for true running of the main spindle and its axial movements.
 - Test for parallelism of spindle axis to guide ways or bearing surfaces.
-
-

- Test for line of movement of various members like spindle and table cross slides etc.

4.5.4 Use of Laser for Alignment Testing

- The alignment tests can be carried out over greater distances and to a greater degree of accuracy using laser equipment.
- Laser equipment produces real straight line, whereas an alignment telescope provides an imaginary line that cannot be seen in space.
- This is important when it is necessary to check number of components to a predetermined straight line. Particularly if they are spaced relatively long distances apart, as in aircraft production and in shipbuilding.
- Laser equipment can also be used for checking flatness of machined surface by direct displacement. By using an optical square in conjunction with laser equipment squareness can be checked with reference to the laser base line.

4.6 CO-ORDINATE MEASURING MACHINES

Measuring machines are used for measurement of length over the outer surfaces of a length bar or any other long member. The member may be either rounded or flat and parallel. It is more useful and advantageous than vernier calipers, micrometer, screw gauges etc. The measuring machines are generally universal character and can be used for works of varied nature. The co-ordinate measuring machine is used for contact inspection of parts. When used for computer-integrated manufacturing these machines are controlled by computer numerical control. General software is provided for reverse engineering complex shaped objects. The component is digitized using CNC, CMM and it is then converted into a computer model which gives the two surface of the component. These advances include for automatic work part alignment on the table. Savings in inspection 5 to 10 percent of the time is required on a CMM compared to manual inspection methods.

4.6.1 Types of Measuring Machines

1. Length bar measuring machine.
2. Newall measuring machine.
3. Universal measuring machine.
4. Co-ordinate measuring machine.
5. Computer controlled co-ordinate measuring machine.

4.6.2 Constructions of CMM

Co-ordinate measuring machines are very useful for three dimensional measurements. These machines have movements in X-Y-Z co-ordinate, controlled and measured easily by using touch probes. These measurements can be made by positioning the probe by hand, or automatically in more expensive machines. Reasonable accuracies are 5 micro in. or 1 micrometer. The method these machines work on is measurement of the position of the probe using linear position sensors. These are based on moiré fringe patterns (also used in other systems). Transducer is provided in tilt directions for giving digital display and senses positive and negative direction.

4.6.3 Types of CMM

(i) Cantilever type

The cantilever type is very easy to load and unload, but mechanical error takes place because of sag or deflection in Y-axis.

(ii) Bridge type

Bridge type is more difficult to load but less sensitive to mechanical errors.

(iii) Horizontal boring Mill type

This is best suited for large heavy work pieces.

(iv) Vertical boring mill type: -

Vertical boring mill is highly accurate but slower to operate.

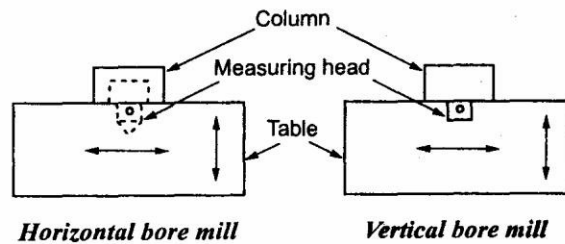
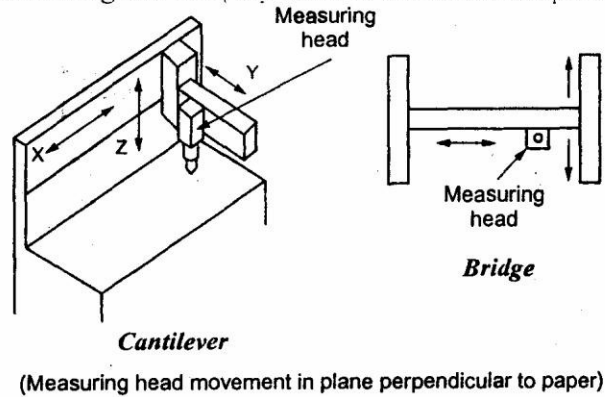

Fig 4.12 Types of CMM

Working Principle

CMM is used for measuring the distance between two holes. The work piece is clamped to the worktable and aligned for three measuring slides x, y and z. The measuring head provides a taper probe tip which is seated in first datum hole and the position of probe digital read out is set to zero. The probe is then moved to successive holes, the read out represent the co-ordinate part print hole location with respect to the datum hole. Automatic recording and data processing units are provided to carry out complex geometric and statistical analysis. Special co-ordinate measuring machines are provided both linear and rotary axes. This can measure various features of parts like cone, cylinder and hemisphere. The prime advantage of co-ordinate measuring machine is the quicker inspection and accurate measurements.

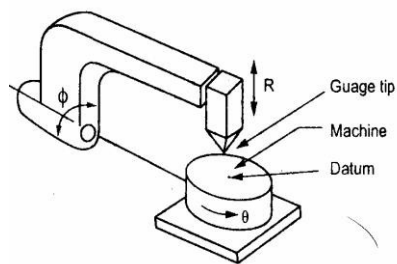

Fig 4.13 Schematic Diagram

4.6.4 Causes of Errors in CMM

- 1) The table and probes are in imperfect alignment. The probes may have a degree of run out and move up and down in the Z-axis may cause perpendicularity errors. So CMM should be calibrated with master plates before using the machine.
- 2) Dimensional errors of a CMM is influenced by
 - Straightness and perpendicularity of the guide ways.
 - Scale division and adjustment.
 - Probe length.
 - Probe system calibration, repeatability, zero point setting and reversal error.
 - Error due to digitization.
 - Environment
- 3) Other errors can be controlled by the manufacture and minimized by the measuring software. The length of the probe should be minimum to reduce deflection.
- 4) The weight of the work piece may change the geometry of the guide ways and therefore, the work piece must not exceed maximum weight.
- 5) Variation in temperature of CMM, specimen and measuring lab influence the uncertainty of measurements.
- 6) Translation errors occur from error in the scale division and error in straightness perpendicular to the corresponding axis direction.
- 7) Perpendicularity error occurs if three axes are not orthogonal.

Fig 4.14 Optical setup

4.6.5 Calibration of Three Co-Ordinate Measuring Machine

The optical set up for the V calibration is shown in figure

The laser head is mounted on the tripod stand and its height is adjusted corresponding to the working table of CMM. The interferometer contains a polarized beam splitter which reflects F1 component of the laser beam and the F2 Component parts through. The retro reflector is a polished trihedral glass prism. It reflects the laser beam

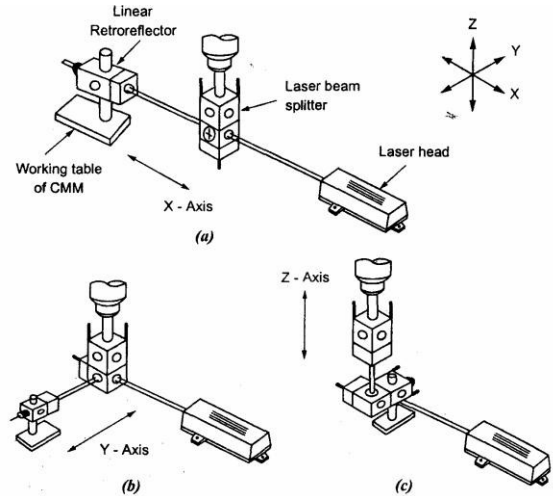

back along a line parallel to the original beam by twice the distance. For distance measurement the F1 and F2 beams that leave the laser head are aimed at the interferometer which splits F1 and F2 via polarizing beam splitter. Component F1 becomes the fixed distance path and F2 is sent to a target which reflects it back to the interferometer. Relative motion between the interferometer and the remote retro reflector causes a Doppler shift in the returned frequency. Therefore the laser head sees a frequency difference given by $F1 - F2 \pm \Delta F2$. The $F1 - F2 \pm \Delta F2$ signal that is returned from the

external interferometer is compared in the measurement display unit to the reference signal. The difference ΔF_2 is related to the velocity. The longitudinal micrometer microscope of CMM is set at zero and the laser display unit is also set at zero. The CMM microscope is then set at the following points and the display units are noted. 1 to 10mm, every mm and 10 to 200mm, in steps of 10mm. The accuracy of linear measurements is affected by changes in air temperature, pressure and humidity.

4.6.6 Performance of CMM

- Geometrical accuracies such as positioning accuracy, Straightness and Squareness.
-

- Total measuring accuracy in terms of axial length measuring accuracy. Volumetric length measuring accuracy and length measuring repeatability. i.e., Coordinate measuring machine has to be tested as complete system.
- Since environmental effects have great influence for the accuracy testing, including thermal parameters, vibrations and relative humidity are required.

4.7 APPLICATIONS

- Co-ordinate measuring machines find applications in automobile, machine tool, electronics, space and many other large companies.
- These machines are best suited for the test and inspect on of test equipment, gauges and tools.
- For aircraft and space vehicles, hundred percent inspections is carried out by using CMM.
- CMM can be used for determining dimensional accuracy of the components.
- These are ideal for determination of shape and position, maximum metal condition, linkage of results etc. which cannot do in conventional machines.
- CMM can also be used for sorting tasks to achieve optimum pairing of components within tolerance limits.
- CMMs are also best for ensuring economic viability of NC machines by reducing their downtime for inspection results. They also help in reducing cost, rework cost at the appropriate time with a suitable CMM.

4.7.1 Advantages

- The inspection rate is increased.
 - Accuracy is more.
 - Operators error can be minimized.
 - Skill requirements of the operator is reduced.
 - Reduced inspection fixturing and maintenance cost.
-

- Reduction in calculating and recording time.
- Reduction in set up time.
- No need of separate go / no go gauges for each feature.
- Reduction of scrap and good part rejection.
- Reduction in off line analysis time.
- Simplification of inspection procedures, possibility of reduction of total inspection time through use of statistical and data analysis techniques.

4.7.2 Disadvantages

- The table and probe may not be in perfect alignment.
- The probe may have run out.
- The probe moving in Z-axis may have some perpendicular errors.
- Probe while moving in X and Y direction may not be square to each other.
- There may be errors in digital system.

4.8 COMPUTER CONTROLLED CO-ORDINATE MEASURING MACHINE

- The measurements, inspection of parts for dimension form, surface characteristics and position of geometrical elements are done at the same time.
- Mechanical system can be divided into four basic types. The selection will be depends on the application.
 1. Column type
 2. Bridge type.
 3. Cantilever type.
 4. Gantry type.

All these machines use probes which may be trigger type or measuring type. This is connected to the spindle in Z direction. The main features of this system are shown figure

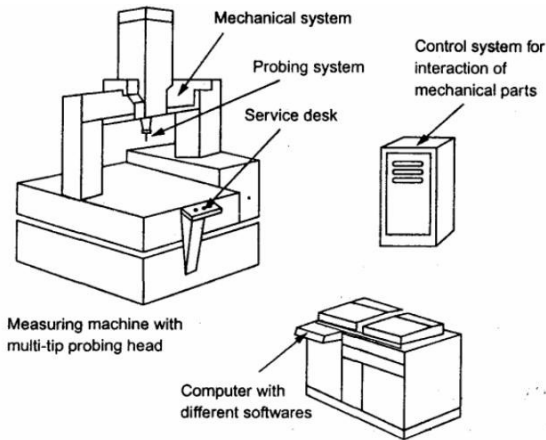

Fig 4.15 Column Type

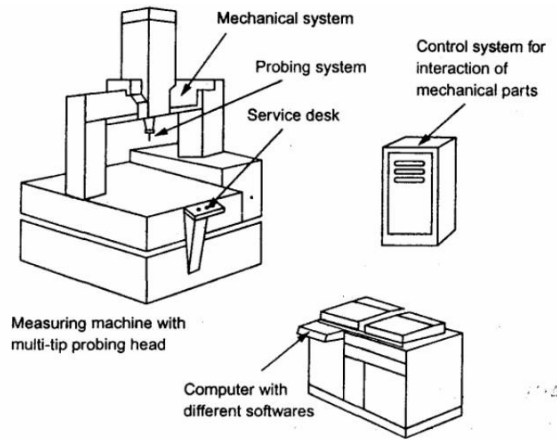
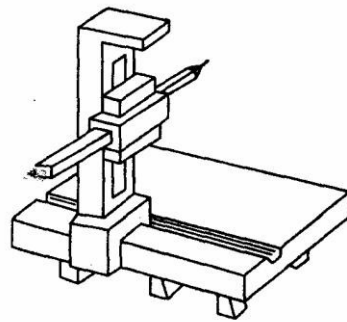
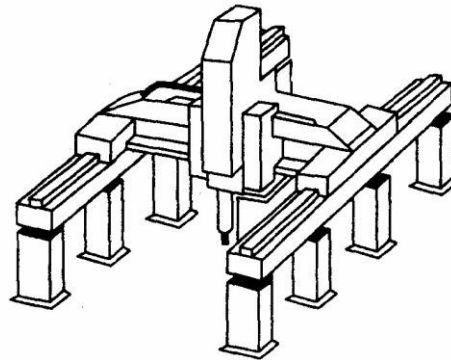

Fig 4.16 Bridge Type



(iii) Cantilever type



(iv) Gantry type

4.8.1 Trigger type probe system

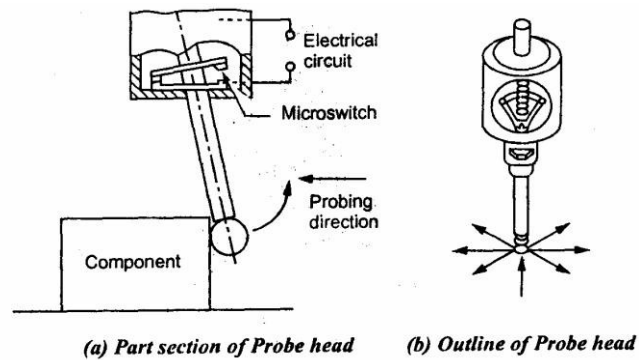

Fig 4.17 Trigger Type Probe System

- The buckling mechanism is a three point bearing the contacts which are arranged at 120° around the circumference. These contacts act as electrical micro switches.
- When being touched in any probing direction one or more contacts is lifted off and the current is broken, thus generating a pulse, when the circuit is opened, the co-ordinate positions are read and stored.
- After probing the spring ensures the perfect zero position of the three-point bearing. The probing force is determined by the prestressed force of the spring with this probe system data acquisition is always dynamic and therefore the measuring time is shorter than in static principle.

Fig 4.18 Buckling Mechanism

4.8.2 Measuring type probe system

□ It is a very small co-ordinate measuring machine in which the buckling mechanism consists of parallel guide ways when probing the spring parallelogram are deflected from their initial position.

□ Since the entire system is free from, torsion, friction, the displacement can be measured

easily.

□ The mathematical model of the mechanical system is shown in figure. If the components of the CMM are assumed as rigid bodies, the deviations of a carriage can be described by three displacement deviations.

□ Parallel to the axes 1, 2 and 3 and by three rotational deviations about the axes 4, 5 and 6. Similarly deviations 7-12 occur for carriage and 13-18 occur for Z carriage and the three squareness deviations 19, 20 and 21 are to be

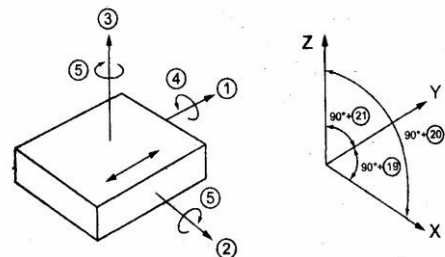
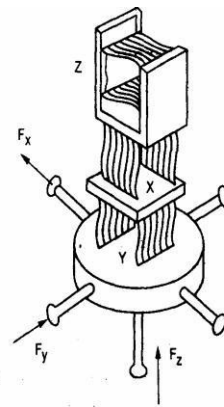

measured and to be treated in the mathematical model.

- Moving the probe stylus in the Y direction the co-ordinate system L is not a straight line but a curved one due to errors in the guide.
 - If moving on measure line L further corrections are required in X, Y and Z coordinates due to the offsets X and Z from curve L resulting from the pitch angle α , the roll angle β and the yaw angle γ .
 - Similarly the deviations of all three carriages and the squareness errors can be taken into account.
 - The effect of error correction can be tested by means of calibrated step gauges.
-

The following test items are carried out for CMM.

(i) Measurement accuracy

- a. Axial length measuring accuracy
- b. Volumetric length measuring accuracy

(ii) Axial motion accuracy

- a. Linear displacement accuracy
- b. Straightness
- c. Perpendicularity
- d. Pitch, Yaw and roll.

The axial length measuring accuracy is tested at the lowest position of the Z-axis. The lengths tested are approximately $1/10$, $1/5$, $2/5$, $3/5$ and $4/5$ of the measuring range of each axis of CMM. The test is repeated five times for each measuring length and results plotted and value of measuring accuracy is derived.

4.9 CNC-CMM

Construction

The main features of CNC-CMM are shown in figure has stationary granite measuring table, Length measuring system. Air bearings; control unit and software are the important parts of CNC & CMM.

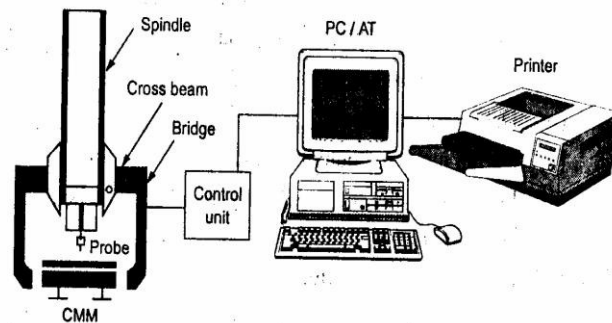

Fig 4.19 CNC - CMM

- Stationary granite measuring table
-

Granite table provides a stable reference plane for locating parts to be measured. It is provided with a grid of threaded holes defining clamping locations and fastening part mounting. As the table has a high load carrying capacity and is accessible from three sides. It can be easily integrated into the material flow system of CIM.

□ **Length measuring system**

A 3- axis CMM is provided with digital incremental length measuring system for each axis.

□ **Air Bearing**

The Bridge cross beam and spindle of the CMM are supported on air bearings.

□ **Control unit**

The control unit allows manual measurement and programme. It is a microprocessor control.

□ **Software**

The CMM, the computer and the software represent one system; the efficiency and cost effectiveness depend on the software.

4.9.1 Features of CMM Software

- (i) Measurement of diameter, center distance, length.
- (ii) Measurement of plane and spatial curves.
- (iii) Minimum CNC programme.
- (iv) Data communications
- (v) Digital input and output command.
- (vi) Programme for the measurement of spur, helical, bevel and hypoid gears.
- (vii) Interface to CAD software.

A new software for reverse engineering complex shaped objects. The component is digitized using CNC CMM. The digitized data is converted into a computer model which is the true surface of the component. Recent advances include the automatic work

part alignment and to orient the coordinate system. Savings in inspection time by using CMM is 5 to 10% compared to manual inspection method.

4.10 COMPUTER AIDED INSPECTION USING ROBOTS

Robots can be used to carry out inspection or testing operation for mechanical dimension physical characteristics and product performance. Checking robot, programmable robot, and co-ordinate robot are some of the types given to a multi axis measuring machines. These machines automatically perform all the basic routines of a CNC co ordinate measuring machine but at a faster rate than that of CMM. They are not as accurate as p as CMM but they can check up to accuracies of 5micrometers. The co-ordinate robot can take successive readings t high speed d evaluate the results using a computer graphics based real time statistical n lysis system.

4.10.1 Integration of CAD/CAM with Inspection System

A product is designed, manufa tured and inspected in one automatic process. One of the critical factors is in manufacturing equality assurance. The co-ordinate measuring machine assists in the equality assurance function. The productivity can be improved by interfacing with CAD/CAM system. This eliminates the labour, reduces preparation time and increases availability of CMM for inspection. Generally the CAD/CAM-CMM interface consists of a nu ber of odules as given

This interface allows to interact with the CAD/CAM database to generate a source file that can be converted to a CMM control data file. During source file creation, CMM probe path motions are simulated and displayed on the CAD/CAM workstation for visual verification. A set of CMM command allow the CMM interface to take advantage of most of the CMM functional capabilities. These command statement include set up, part datum

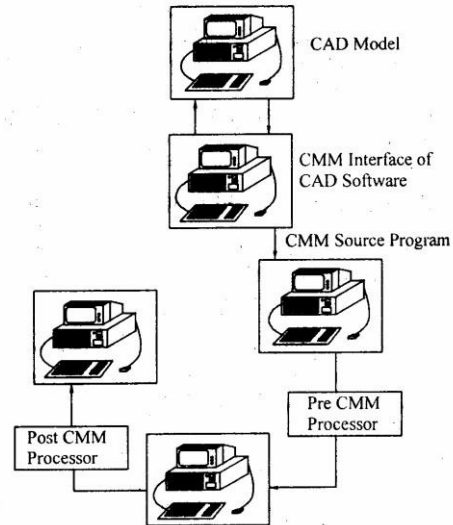

Fig 4.20 CMM Interface

control, feature construction, geometric relations, tolerance, output control and feature measurements like measurements of lines, points, arcs, circles, splines, conics, planes, analytic surfaces.

(2) Pre- processor

The pre-CMM processor converts the language source file generated by CMM interface into the language of the specified co ordinate measuring machine.

(3) Post-CMM processor

This creates ire frame surface model from the CMM-ASCII output file commands are inserted into the ASCJI-CMM output file to control the creation of CAD/CAM high include points, lines, arcs, circles, conics, splines and analytic surfaces.

Fig 4.21 Flexible Inspection System

4.10.2 Flexible Inspection System

The block diagram of flexible inspection system is shown in figure. This system has been developed and the inspection done at several places in industry. This system helps product performance to improve inspection and increase productivity. FIS is the Real time processor to handle part dimensional data and as multi programming system to perform

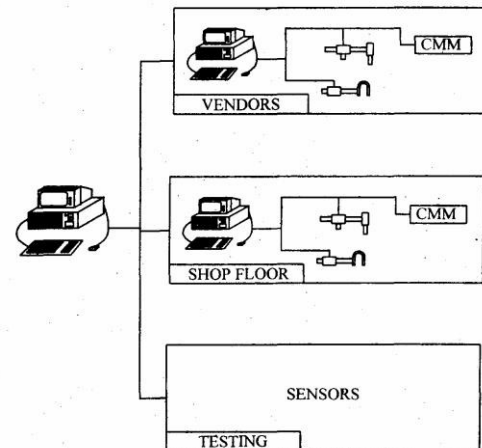

manufacturing process control. The input devices used with this system are CMM's; Microprocessor based gauges and other inspection devices. The terminal provides interactive communication with personal computers where the programmes are stored. The data from CMMs and other terminals are fed into the main computer for analysis and feedback control. The equality control data and inspection data from each station are fed through the terminals to the main computer. The data will be communicated through telephone lines. Flexible inspection system involves more than one inspection station. The objective of the flexible inspection system is to have off time multi station automated dimensional verification system to increase the production rate and less inspection time and to maintain the inspection accuracy and data processing integrity.

4.10.3 Machine Vision

A Vision system can be defined as a system for automatic acquisition and analysis of images to obtain desired data for interpreting or controlling an activity. It is a

technique which allows a sensor to view a scene and derive a numerical or logical decision without further human intervention. Machine vision can be defined as a means of simulating the image recognition and analysis capabilities of the human system with electronic and electro mechanical techniques. Machine vision systems are now a days used to provide accurate and in expensive 100% inspection of work pieces. These are used for functions like gauging of dimensions, identification of shapes, measurement of distances, determining orientation of parts, quantifying motion-detecting surface shading etc. It is best suited for high production. These systems function without fatigue. This is suited for inspecting the masks used in the production of micro-electron devices. Standoff distance up to one meter is possible.

4.10.4 Vision System

The schematic diagram of a typical vision system is shown. This system involves image acquisition; image processing Acquisition requires appropriate lighting. The camera and store digital image processing involves manipulating the digital image to simplify and reduce number of data points. Measurements can be carried out at any angle along the three reference axes x y and z without contacting the part. The measured values are then compared with the specified tolerance which stores in the memory of the computer.

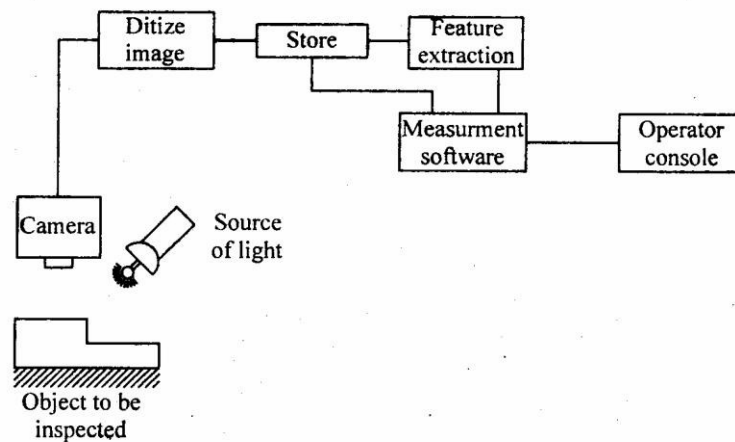

Fig 4.22 Machine Vision

The main advantage of vision system is reduction of tooling and fixture costs, elimination of need for precise part location for handling robots and integrated automation of dimensional verification and defect detection.

Principle

Four types of machine vision system and the schematic arrangement is shown

- (i) Image formation.
- (ii) Processing of image in a form suitable for analysis by computer.
- (iii) Defining and analyzing the characteristic of image.
- (iv) Interpretation of image and decision-making.

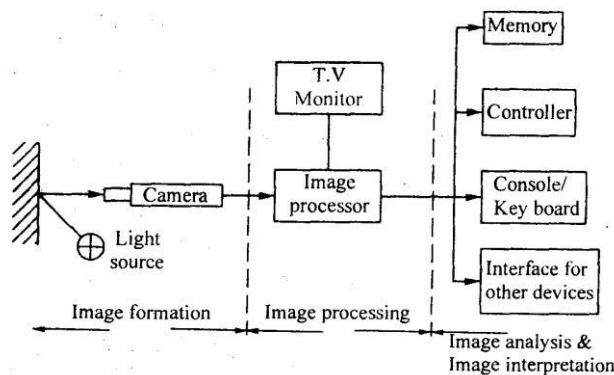

Fig 4.23 Schematic arrangement of Machine Vision

Image formation:

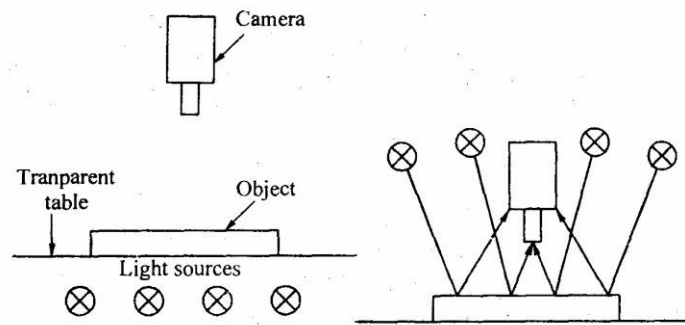

Fig 4.24 Image Formation

For formation of image suitable light source is required. It consists of incandescent light, fluorescent tube, fiber optic bundle, arc lamp. Laser beam is used for triangulation system for measuring distance. Ultraviolet light is used to reduce glare or increase contrast. Proper illumination back lighting, front lighting, structured light is required. Back lighting is used to obtain maximum image contrast. The surface of the object is to be inspected by using front lighting. For inspecting three-dimensional feature structured lighting is required. An image sensor vidicon camera, CCD camera is used to generate the electronic signal representing the image. The image sensor collects light from the scene through a lens, using photosensitive target, converts into electronic signal.

Vidicon camera

Image is formed by focusing the incoming light through a series of lenses onto the photoconductive faceplate of the vidicon tube. The electron beam scans the photoconductive surface and produces an analog voltage proportional to the variation in light intensity for each scan line of the original scene.

Solid-state camera

The image sensors charge coupled device (CCD) contain matrix of small array, photosensitive elements accurately spaced and fabricated on silicon chips using

integrated circuit technology. Each detector converts in to analog signal corresponding to light intensity through the camera lens.

Image processor

A camera may form an image 30 times per sec at 33 m sec intervals. At each time interval the entire image is frozen by an image processor for processing. An analog to digital converter is used to convert analog voltage of each detector into digital value. If voltage level for each pixel is given by either 0 or 1 depending on threshold value. It is called binary system on the other hand grey scale system assigns upto 256 different values depending on intensity to each pixel. Grey scale system requires higher degree of image refinement, huge storage processing capability. For analysis 256 x 256 pixels image array up to 256 different pixel values will require 65000-8 bit storage locations at a speed of 30 images per second. Techniques windowing and image restoration are involved.

Windowing

Processing is the desired area of interest and ignores non-interested part of image.

Image restoration

Preparation of image during the pre-processing by removing the degradation. Blurring of lines, poor contrast between images and presence of noise are the degrading. The quality may be improved

- 1) By improving the contrast by brightness addition.
 - 2) By increasing the relative contrast between high and low intensity elements.
 - 3) By Fourier domain processing.
 - 4) Other techniques to reduce edge detection and run length encoding.
-

Image Analysis

Digital image of the object formed is analyzed in the central processing Unit of the system. Three important tasks performed by machine vision system are measuring the distance of an object from a vision system camera, determining object orientation and defining object position. The distance of an object from a vision system camera can be determined by **triangulation technique**. The object orientation can be determined by the methods of **equivalent ellipse**. The image can be interpreted by two-dimensional image. For complex three-dimensional objects boundary locations are determined and the image is segmented into distinct region.

Image Interpretation

This involves identification of an object. In binary system, the image is segmented on the basis of white and black pixels. The complex images can be interpreted by grey scale technique and algorithms. The most common image interpretation is template matching.

4.10.5 Function of Machine Vision

- Lighting and presentation of object to be evaluated.
 - It has great impact on repeatability, reliability and accuracy.
 - Lighting source and projection should be chosen and give sharp contrast.
 - Images sensor compressor TV camera may be vidicon or solid state.
 - For simple processing, analog comparator and a computer controller to convert the video information to a binary image is used.
 - Data compactor employs a high speed array processor to provide high speed processing of the input image data.
-

- System control computer communicates with the operator and make decision about the part being inspected.
- The output and peripheral devices operate the control of the system The output enables the vision system to either control a process or provide caution and orientation information two a robot, etc.
- These operate under the control of the system control of computer.

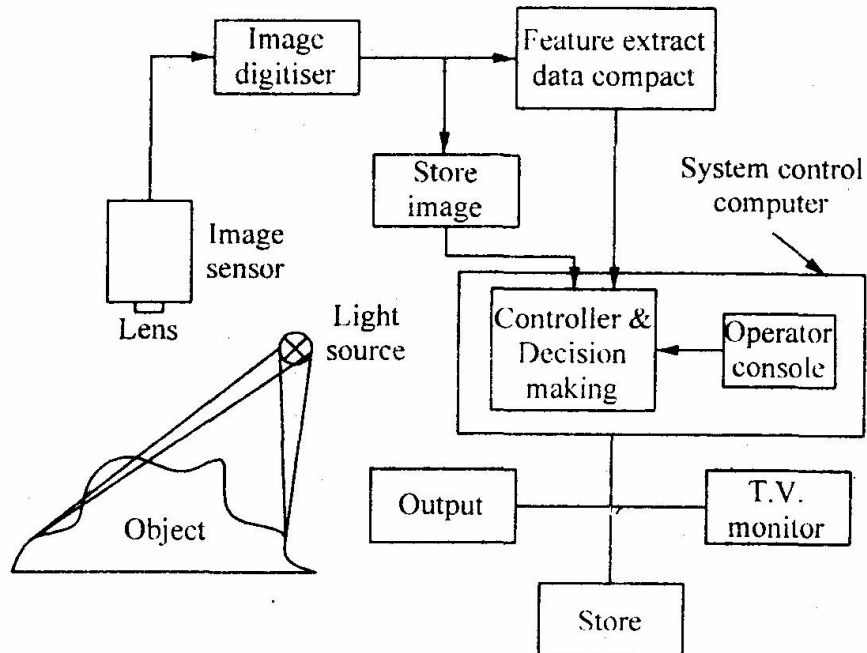

Fig 4.25 Functions of Machine Vision

4.10.6 Applications

- Machine vision can be used to replace human vision for welding. Machining and maintained relationship between tool and work piece and assembly of parts to analyze the parts.
- This is frequently used for printed circuit board inspection to ensure minimum conduction width and spacing between conductors. These are used for weld seam tracking, robot guidance and control, inspection of microelectronic devices and

tooling, on line inspection in machining operation, assemblies monitoring high-speed packaging equipment etc.

- It gives recognition of an object from its image. These are designed to have strong geometric feature interpretation capabilities and pa handling equipment

Part-A (2 Marks)

1. Name the different types of interferometer?
2. Name the common source of light used for interferometer
3. What is crest and trough?
4. What is wavelength?
5. What is meant by alignment test on machine tools?
6. List the various geometrical checks made on machine tools.
7. Distinguish between geometrical test and practical test on a machine tool.
8. What are the main spindle errors?
9. Write the various tests conducted on any machine tools
10. Why the laser is used in alignment testing?
11. Classify the machine tool test.
12. What are the different types of geometrical tests conducted on machine tools?
13. What is CMM?

Part – B (16 Marks)

1. With neat sketch explain the various types of CMM based on its construction. Write the advantages of computer aided inspection.
 2. Explain the construction and working principle of laser interferometer with neat diagram? Explain the use of laser interferometer in angular measurement.
 3. Explain with a neat sketch the working of talysurf instrument for surface finish measurement. What is the symbol for fully defining surface roughness and explain each term?
 4. Describe in detail the method of checking roundness by using Roundness Measuring Machine. State its advantages.
 5. Sketch and describe the optical system of a laser interferometer.
-

6. Define explain the working principle of Tomlinson surface meter with a neat sketch.
Define straightness. Describe any one method of measuring straightness of a surface.
 7. Explain how the straightness error of a Lathe bed is checked using a Auto-collimator
 8. With neat sketches, explain the significance of some important parameters used for measuring surface roughness. Why so many parameters are needed?
 9. How surface finish is measured using LASER. How the angle is measured using a laser interferometer?
 10. Discuss the steps involved in computing flatness of surface plate.
 11. How are CMMs classified with respect to constructional features? Sketch and state their main applications, merits and demerits.
-

MODULE-V

MEASUREMENT OF FORCE, TORQUE AND TEMPERATURE



CONTENTS

- 5.1 MEASUREMENT OF FORCE
 - 5.1.1 Devices to measure Force
 - 5.1.2 Scale and balances
 - 5.1.3 Elastic force meter (Proving Ring)
 - 5.1.4 Load cells
 - 5.2 TORQUE MEASUREMENT
 - 5.2.1 Measurement of Induced Strain
 - 5.2.2 Optical Torque Measurement
 - 5.2.3 Reaction Forces in Shaft Bearings
 - 5.2.4 Prony Brake
 - 5.3 MEASUREMENT OF POWER
 - 5.3.1 Mechanical Dynamometers
 - 5.3.2 Eddy Current Dynamometer
 - 5.3.3 Hydraulic or Fluid Friction Dynamometer
 - 5.4 FLOW MEASUREMENTS
 - 5.4.1 Orifice Flow M t r
 - 5.4.2 Venturi M t r
 - 5.4.3 Flow Nozzle
 - 5.4.4 Pitot tube
 - 5.4.5 Rota eter
 - 5.5 TEMPERATURE MEASUREMENT
 - 5.6 Mechanical Temperature Measuring Devices
 - 5.6.1 Bimetallic strip thermometer
 - 5.6.2 Pressure thermometer
 - 5.7 THERMOCOUPLES (Thermo-junctive temperature measuring devices)
 - 5.7.1 Thermocouple Materials
 - 5.7.2 Laws of Thermocouple
 - 5.8 THERMORESISTIVE TEMPERATURE MEASURING DEVICES
-

5.8.1 Resistance temperature detectors

5.8.2 Thermistors

Technical Terms

- **Force:** The mechanical quantity which changes or tends to change the motion or shape of a body to which it is applied

 - **Load Cells:** Load cells are devices for the force measurement through indirect methods

 - **Torque:** Torque can be defined as a measure of the tendency of a force to rotate the body on which it acts about an axis.

 - **Thermocouple:** When two dissimilar metals are joined together, it will create an emf it is primarily a function of the junction temperature.

 - **Flow meter:** Flow meter is a device that measures the rate of flow or quantity of a moving fluid in an open or closed conduit.

 - **Thermometry:** Thermometry is the science and practice of temperature measurement. Any measurable change in a thermometric probe can be used to mark temperature levels that should later be calibrated against an internationally agreed unit if the measure is to be related to other thermodynamic variables.

 - **Resistance Temperature Detectors:** RTD as the name implies, are sensors used to measure temperature by correlating the resistance of the RTD element with temperature.
-

- **Dynamometer:** A dynamometer or "dyno" for short is a device used to measure power and torque produced by an engine.



5.1 MEASUREMENT OF FORCE

The mechanical quantity which changes or tends to change the motion or shape of a body to which it is applied is called force. Force is a basic engineering parameter, the measurement of which can be done in many ways as follows:

- Direct methods
- Indirect methods

□ Direct methods

It involves a direct comparison with a known gravitational force on a standard mass, say by a balance.

□ Indirect methods

It involves the measurement of effect of force on body, such as acceleration of a body of known mass subjected to force.

5.1.1 Devices to measure Force

- Scale and balances
 - a. Equal arm balance
 - b. Unequal arm balance
 - c. Pendulum scale
 - Elastic force meter (Proving ring)
 - Load cells
 - a. Strain gauge load cell
 - b. Hydraulic load cell
 - c. Pneumatic load cell
-
-

5.1.2 Scale and balances

a. Equal arm balance

An equal arm balance works on the principle of moment comparison. The beam of the equal arm balance is in equilibrium position when,

Clockwise rotating moment = Anti-clockwise rotating moment

$$M_2L_2 = M_1L_1$$

That is, the unknown force is balanced against the known gravitational force.

Description

The main parts of the arrangement are as follows:

- A beam whose centre is pivoted and rests on the fulcrum of a knife edge. Either side of the beam is equal in length with respect to the fulcrum.
- A pointer is attached to the center of the beam. This pointer will point vertically downwards when the beam is in equilibrium.
- A provision to place masses at either end of the beam.

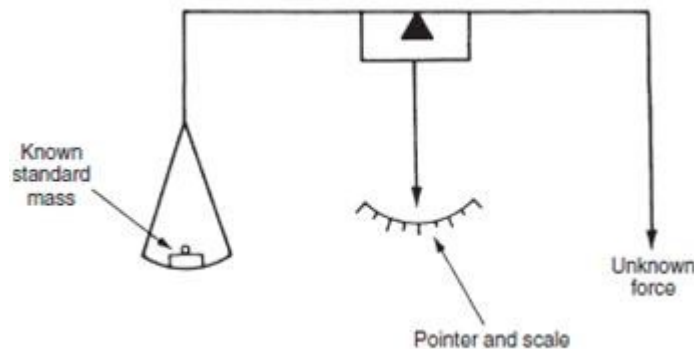

Fig 5.1 Equal Arm Balance

Operation

- A known standard mass (m_1) is placed at one end of the beam and an unknown mass (m_2) is placed at its other end.
-

- Moreover at a given location, the earth's attraction will act equally on both the masses (m_1 and m_2) and hence at equilibrium condition. $W_1=W_2$. That is, the unknown force (weight) will be equal to the known force (weight)

b. Unequal arm balance

An unequal arm balance works on the principle of moment comparison.

The beam of the unequal arm balance is in equilibrium position when,

Clockwise rotating moment = Anti-clockwise rotating moment

$$F \times L_2 = F_x \times L_1$$

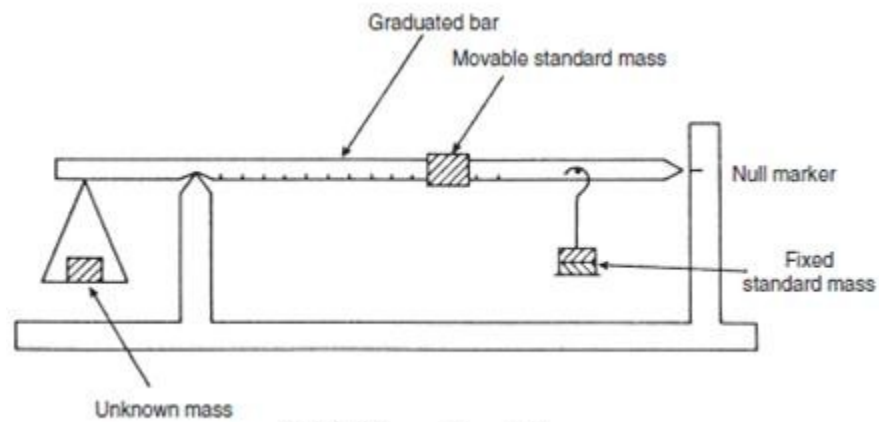

Fig 5.2 Unequal Arm Balance

Description

The main parts of the arrangements are as follows:

- A graduated beam pivoted to a knife edge “Y”
- A leveling pointer is attached to the beam
- A known mass “m” is attached to the right side of the beam. This creates an unknown force “F”. This mass “m” can slide on the right side of the beam.
- Provisions are made to apply an unknown force “ F_x ” on the left side of the beam.
- An unknown force “ F_x ” is applied on the left side of the beam through knife edge “Z” as shown

- Now the position of mass “m” on the right side of the beam is adjusted until the leveling pointer reads null balance position. When the leveling pointer is in null balance position, the beam is in equilibrium.

Clock wise rotating moment = Anti-clock wise rotating moment

- Thus the unknown force “ F_x ” is proportional to the distance “ L_2 ” of the mass “m” from the knife edge “Y”
- The right hand side of the beam which is graduated is calibrated to get a direct measure of “ F_x ”

c. Pendulum Scale(Multi-lever Type)

It is a moment comparison device. The unknown force is converted to torque which is then balanced by the torque of a fixed standard mass arranged as a pendulum.

Description

- The scale’s frame carries support ribbons. These support ribbons are attached to the sectors. The loading ribbons are attached to the sectors and the load rod as shown. The load rod is in turn attached to the weighing platform.
- The two sectors are connected on either side of an equalizer beam. The sectors carry counter weights. To the center of the equalizer beam is attached a rack and pinion arrangement.
- A pointer is attached to the pinion which sweeps over a weight (force) calibrated scale.

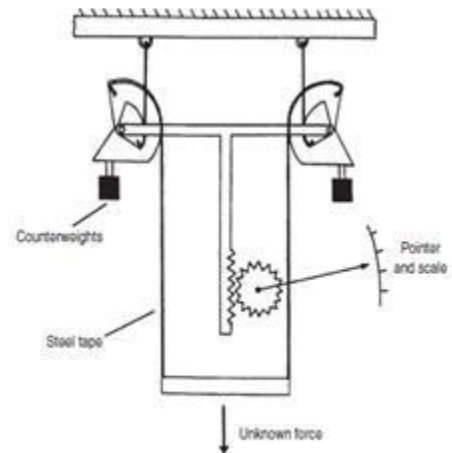

Fig 5.3 Pendulum Scale

calibrated scale.

Operation

- The unknown force is applied to the load rod. Due to this force, the loading tapes are pulled downwards. Hence the loading tapes rotate the sectors
- As the sectors rotate about the pivots, it moves the counter weights outwards, This movements increases the counter weight effective moment until the torque produced by the force applied to the load rod and the moment produced by the counter weight balance each other, thereby establishing an equilibrium.
- During the process of establishing equilibrium, the equalizer beam would be displaced downwards. As the rack is attached to the equalizer beam, the rack also is displaced downwards rotating the pinion.
- As the pointer is attached to the pinion, the rotation of the pinion makes the pointer to assume a new position on the scale. The scale is calibrated to read the weight directly. Thus the force applied on the load rod is measured.

5.1.3 Elastic force meter (Proving Ring)

When a steel ring is subjected to a force across its diameter, it deflects. This deflection is proportional to the applied force when calibrated.

Description

A steel ring attached with external bosses to apply force. A precision micrometer with one of its ends mounted on a vibrating reed.

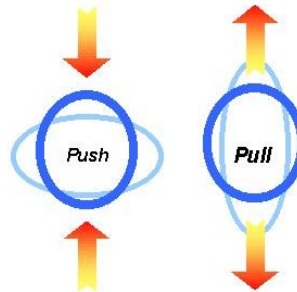

Fig 5.4 Proving Ring

Operation

- The force to be measured is applied to the external bosses of the proving ring. Due to the applied force, the ring changes in diameter. This deflection of the ring is proportional to the applied force.
- At this stage, the reed is plucked to obtain a vibrating motion. When the reed is vibrating, the micrometer wheel is turned until the micrometer contact moves forward and makes a noticeable damping of the vibrating reed.
- Now the micrometer reading is noted which is a measure of deflection of the ring. The device is calibrated to get a measure of force in terms of deflection of the proving ring.

5.1.4 Load cells

a. Strain gauge load cell

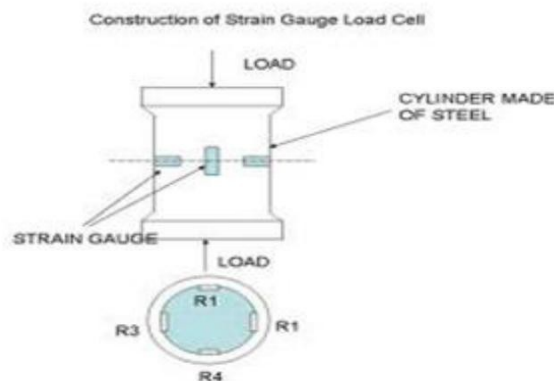

Fig 5.5 Strain Gauge Load Cell

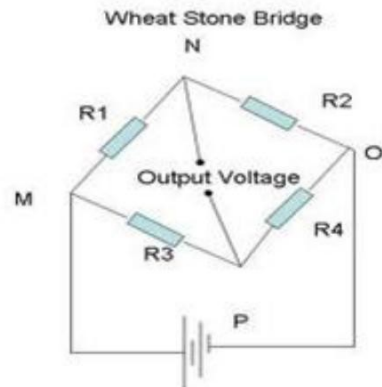

Fig 5.6 Wheat Stone Bridge

- When a steel cylinder is subjected to a force, it tends to change in dimension. On this cylinder if strain gauges are bonded, the strain gauge also is stretched or compressed, causing a change in its length and diameter.
- This change in dimension of the strain gauge causes its resistance to change. This change in resistance of the strain gauge becomes a measure of the applied force.
- A cylinder made of steel on which four identical strain gauges are mounted.

- Out of the four strain gauges, two of them (R1 and R4) are mounted along the direction of the applied load (Vertical gauges)
- The other two strain gauges (R2 and R3 horizontal gauges) are mounted circumferentially at right angles to gauges R1 and R4.
- The four gauges are connected to the four limbs of wheat stone bridge. Operation
- When there is no load on the steel cylinder, all the four gauges will have the same resistance. As the terminals N and P are at the same potential, the wheat stone bridge is balanced and hence the output voltage will be zero.
- Now the force to be measured is applied on the steel cylinder. Due to this, the vertical gauges R1 and R4 will undergo compression and hence there will be a decrease in resistance. At the same time, the horizontal gauges R2 and R3 will undergo tension and there will be an increase in resistance. Thus when strained, the resistance of the various gauges change.
- Now the terminals N and P will be at different potential and the change in output voltage due to the applied load becomes a measure of the applied load when calibrated.

b. Hydraulic Load Cell

- When a force is applied on liquid medium contained in a confined space, the pressure of the liquid increases. This increase in pressure of the liquid is proportional to the applied force. Hence a measure of the increase in pressure of the liquid becomes a measure of the applied force when calibrated.
-

□ The force to be measured is applied to the piston

□ The applied force moves the piston downwards and deflects the diaphragm and this deflection of the diaphragm increases the pressure in the liquid medium.

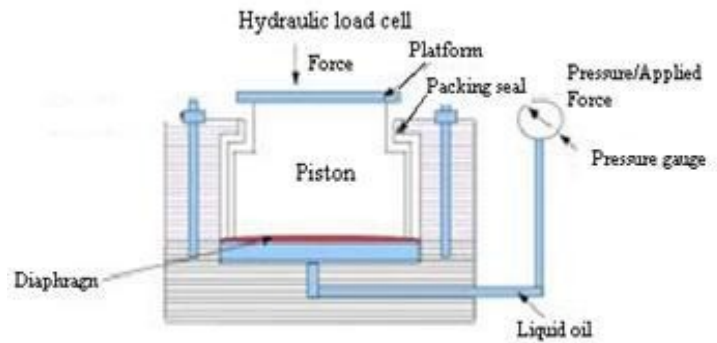

Fig 5.7 Hydraulic Load Cell

□ This increase in pressure of the liquid medium is proportional to the applied force. This increase in pressure is measured by the pressure gauge which is connected to the liquid medium.

□ The pressure is calibrated in force units and hence the indication in the pressure gauge becomes a measure of the force applied on the piston.

c. Pneumatic load cells

□ If a force is applied to one side of a diaphragm and an air pressure is applied to the other side, some particular value of pressure will be necessary to exactly balance the force. This pressure is proportional to the applied force.

□ The force to be measured is applied to the top side of the diaphragm. Due to this force, the diaphragm deflects and causes the flapper to shut-off the nozzle opening.

□ Air supply is provided at the bottom of the diaphragm. As the flapper closes the nozzle opening, a back pressure results underneath the diaphragm.

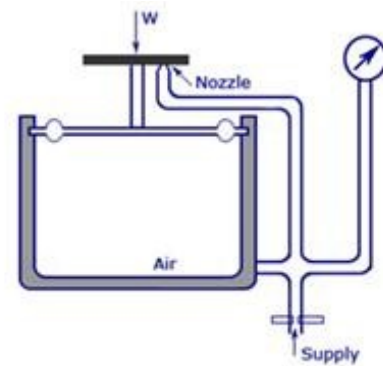

Fig 5.8 Pneumatic Load Cell

- This back pressure acts on the diaphragm producing an upward force. Air pressure is regulated until the diaphragm returns to the pre-loaded position which is indicated by air which comes out of the nozzle.
- At this stage, the corresponding pressure indicated by the pressure gauge becomes a measure of the applied force when calibrated.

5.2 TORQUE MEASUREMENT

- Measurement of applied torques is of fundamental importance in all rotating bodies to ensure that the design of the rotating elements adequate to prevent failure under shear stresses.
 - Torque measurement is also a necessary part of measuring the power transmitted by rotating shafts.
 - The four methods of measuring torque consist of
 - Measuring the strain produced in a rotating body due to an applied torque
 - An optical method
 - Measuring the reaction force in cradled shaft bearings
 - Using equipment known as the Prony brake.
-
-

5.2.1 Measurement of Induced Strain

Measuring the strain induced in a shaft due to an applied torque has been the most common method used for torque measurement in recent years. The method involves bonding four strain gauges onto a shaft as shown in Figure, where the strain gauges are arranged in a d.c. bridge circuit. The output from the bridge circuit is a function of the strain in the shaft and hence of the torque applied. It is very important that the positioning of the strain gauges on the shaft is precise, and the difficulty in achieving this makes the instrument relatively expensive. This technique is ideal for measuring the stalled torque in a shaft before rotation commences. However, a problem is encountered in the case of rotating shafts because a suitable method then has to be found for making the electrical connections to the strain gauges. One solution to this problem found in many commercial instruments is to

use a system of slip rings and brushes for this, although this increases the cost of the instrument still further.

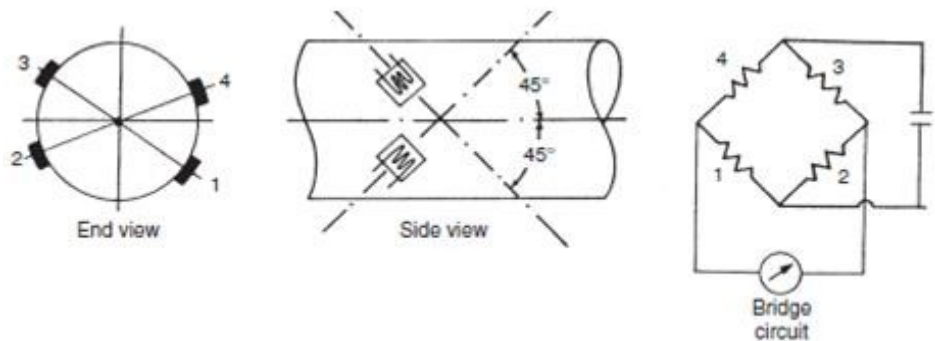

Fig 5.9 Induced Strain Gauge

5.2.2 Optical Torque Measurement

Optical techniques for torque measurement have become available recently with the development of laser diodes and fiber-optic light transmission systems. One such system is shown in Figure. Two black-and-white striped wheels are mounted at either end of the rotating shaft and are in alignment when no torque is applied to the shaft. Light

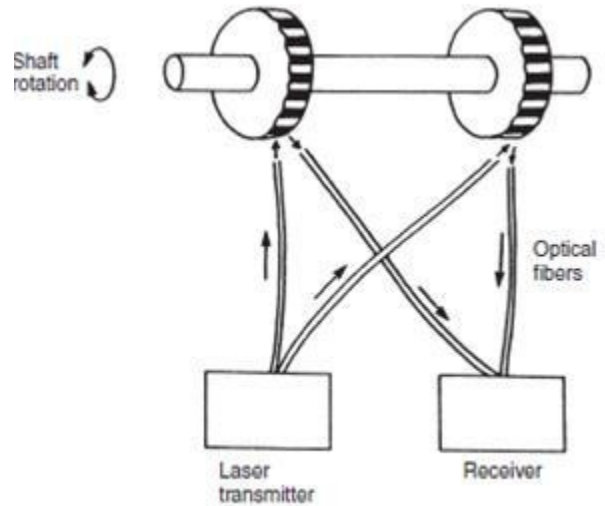

Fig 5.10 Optical Torqu Measurement

from a laser diode light source is directed by pair of fiber-optic cables onto the wheels. The rotation of the wheels causes pulses of reflected light, which are transmitted back to a receiver by a second pair of fiber-optic cables. Under zero torque conditions, the two pulse trains of reflected light are in phase with each other. If torque is now applied to the shaft, the reflected light is modulated. Measurement by the receiver of the phase difference between the reflected pulse trains therefore allows the magnitude of torque in the shaft to be calculated. The cost of such instruments is relatively low, and an additional advantage in many applications is their small physical size.

5.2.3 Reaction Forces in Shaft Bearings

Any system involving torque transmission through a shaft contains both a power source and a power absorber where the power is dissipated. The magnitude of the transmitted torque can be measured by cradling either the power source or the power absorber end of the shaft in bearings, and then measuring the reaction force, F , and the arm length, L , as shown in Figure. The torque is then calculated as the simple product, FL . Pendulum scales are used very commonly for measuring the reaction force. Inherent errors in the method are bearing friction and windage torques. This technique is no longer in common use.

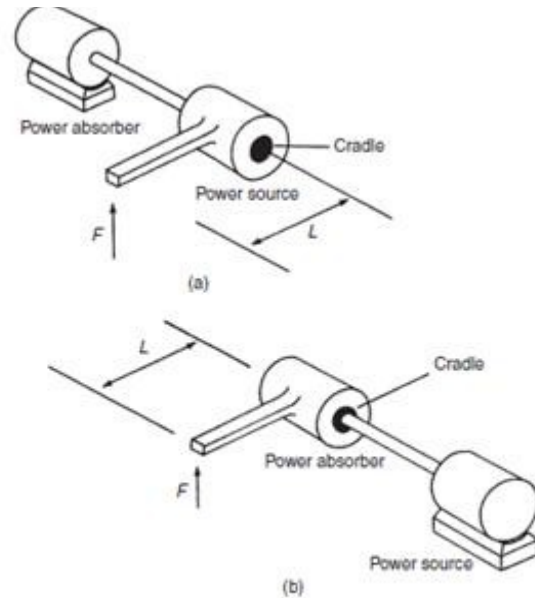

Fig 5.11 Measuring Reaction forces in cradled shaft bearing



5.2.4 Prony Brake

The Prony brake is another torque-measuring system that is now uncommon. It is used to measure the torque in a rotating shaft and consists of a rope wound round the shaft, as illustrated in Figure. One end of the rope is attached to a spring balance and the other end carries a load in the form of a standard mass, m . If the measured force in the spring balance is F_s , then the effective force, F_e , exerted by the rope on the shaft is given by

$$F_e = mg - F_s$$

If the radius of the shaft is R_s and that of the rope is R_r , then the effective radius, R_e , of the rope and drum with respect to the axis of rotation of the shaft is given by

$$R_e = R_s + R_r$$

The torque in the shaft, T , can then be calculated as

$$T = F_e R_e$$

While this is a well-known method of measuring shaft torque, a lot of heat is generated because of friction between the rope and shaft, and water cooling is usually necessary.

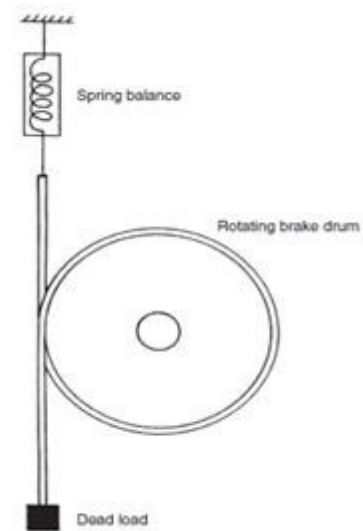

Fig 5.12 Prony Brake

5.3 MEASUREMENT OF POWER

Torque is exerted along a rotating shaft. By measuring this torque which is exerted along a rotating shaft, the shaft power can be determined. For torque

measurement dynamometers are used.

$$T = F \cdot r$$

$$P = 2\pi NT$$

Where, T – Torque, F – Force at a known radius r , P – Power

Types of dynamometers

- Absorption dynamometers
- Driving dynamometers
- Transmission dynamometers

Absorption dynamometers

The dynamometer absorbs the mechanical energy when torque is measured. It dissipates mechanical energy (heat due to friction) when torque is measured. Therefore, dynamometers are used to measure torque/power of power sources like engine and motors.

5.3.1 Mechanical Dynamometers

In prony brake, mechanical energy is converted into heat through dry friction between the wooden brake blocks and the flywheel (pulley) of the machine. One block carries a lever arm. An

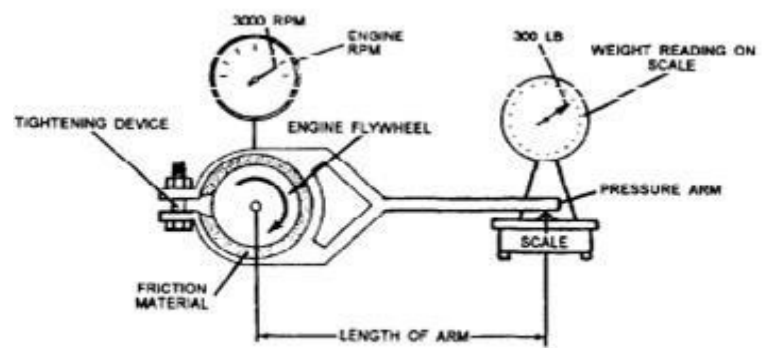

Fig 5.13 Mechanical Dynamometer

arrangement is provided to tighten the rope which is connected to the arm. Rope is tightened so as to increase the frictional resistance between the blocks and the pulley.

Power dissipated, $P = 2\pi NT/60$

The capacity of prony brake is limited due to wear of wooden blocks, friction coefficient varies. So, it is unsuitable for large powers when it is used for long periods.

5.6 Eddy Current Dynamometer

Basically an electrical dynamometer of absorption type, used to measure power from a source such as engine or a motor. When a conducting material moves through a magnetic flux field, voltage is generated, which causes current to flow. If the conductor is a wire forming, a part of a complete circuit current will be caused to flow through that circuit and with some form of commutating device a form of A.C or D.C generator may result.

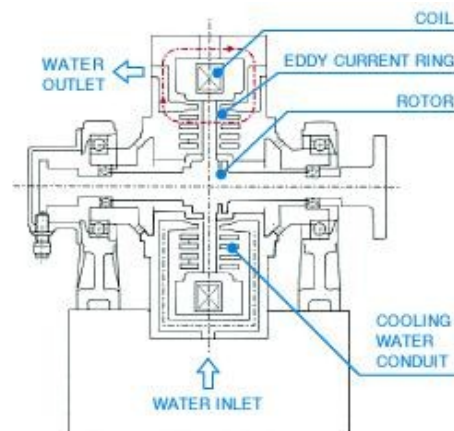

Fig 5.14 Eddy current Dynamometer

An eddy current dynamometer is shown above. It consists of a metal disc or wheel which is rotated in the flux of a magnetic field. The field is produced by field elements or coils is excited by an external source and attached to the dynamometer housing which is mounted in trunnion bearings. As the disc turns, eddy currents are generated. Its reaction with the magnetic field tends to rotate the complete housing in the trunnion bearings. Water cooling is employed.

5.6 Hydraulic or Fluid Friction Dynamometer

A rotating disk that is fixed to the driving shaft, Semi-elliptical grooves are provided on the disc through which a stream of water flows. There is a casting which is stationary and the disc rotates in this casing. When the driving shaft rotates, water flow is in a helical path in the chamber. Due to vortices and eddy-currents setup in the water, the casting tends to rotate in the same direction as that of the driving shafts. By varying the amount of water, the braking action is provided. Braking can also be provided by varying the distance between the rotating disk and the casting. The absorbing element is constrained by a force-measuring device placed at the end of the arm of radius r .

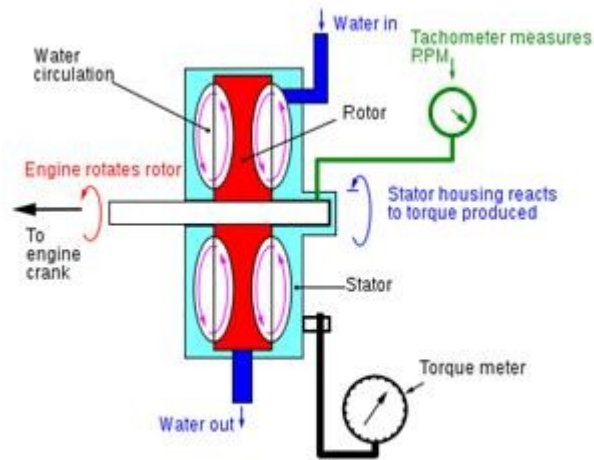

Fig 5.15 Hydraulic Dynamometer

5.4 FLOW MEASUREMENTS

The flow rate of a fluid flowing in a pipe under pressure is measured for a variety of applications, such as monitoring of pipe flow rate and control of industrial processes. Differential pressure flow meters, consisting of orifice, flow nozzle, and venturi meters, are widely used for pipe flow measurement and are the topic of this course. All three of these meters use a constriction in the path of the pipe flow and measure the difference in pressure between the undisturbed flow and the flow through the constriction. That pressure difference can then be used to calculate the flow rate. Flow meter is a device that measures the rate of flow or quantity of a moving fluid in an open or closed conduit. Flow measuring devices are generally classified into four groups. They are

1. Mechanical type flow meters

Fixed restriction variable head type flow meters using different sensors like orifice plate, venturi tube, flow nozzle, pitot tube, dall tube, quantity meters like positive displacement meters, mass flow meters etc. fall under mechanical type flow meters.

2. Inferential type flow meters

Variable area flow meters (Rotameters), turbine flow meter, target flow meters etc.

3. Electrical type flow meters

Electromagnetic flow meter, Ultrasonic flow meter, Laser doppler Anemometers etc. fall under electrical type flow meter.

4. Other flow meters

Purge flow regulators, Flow meters for Solids flow measurement, Cross-correlation flow meter, Vortex shedding flow meters, flow switches etc.

5.4.1 Orifice Flow Meter

An Orifice flow meter is the most common head type flow measuring device. An orifice plate is inserted in the pipeline and the differential pressure across it is measured.

Principle of Operation

The orifice plate inserted in the pipeline causes an increase in flow velocity and a corresponding decrease in pressure. The flow pattern shows an effective decrease in cross section beyond the orifice plate, with a maximum velocity and minimum pressure at the venacontracta.

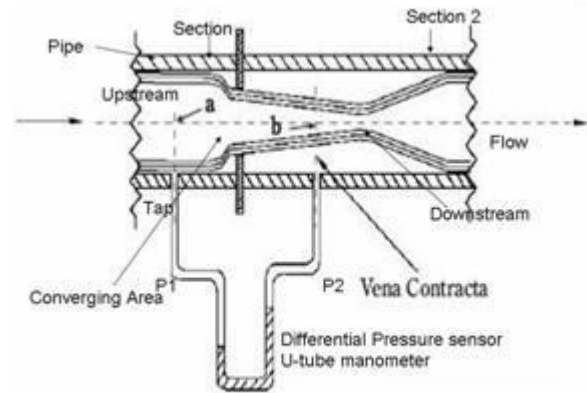

Fig 5.16 Orifice Meter

The flow pattern and the sharp leading edge of the orifice plate which produces it are of major importance. The sharp edge results in an almost pure line contact between

the plate and the effective flow, with the negligible fluid-to-metal friction drag at the boundary.

Types of Orifice Plates

The simplest form of orifice plate consists of a thin metal sheet, having in it a square edged or a sharp edged or round edged circular hole.

There are three types of orifice plates namely

1. Concentric
2. Eccentric and
3. Segmental type.

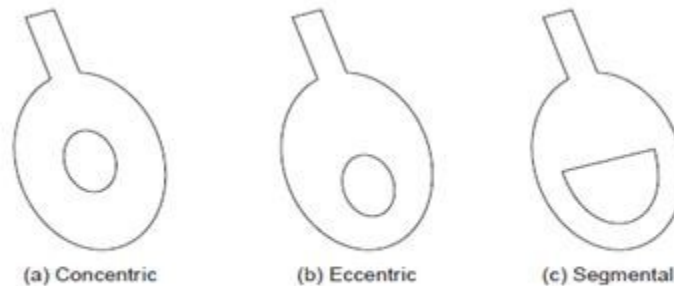

Fig 5.17 Types of Orifice Plates

The concentric type is used for clean fluids. In metering dirty fluids, slurries and fluids containing solids, eccentric or segmental type is used in such a way that its lower edge coincides with the inside bottom of the pipe. This allows the solids to flow through without any obstruction. The orifice plate is inserted into the main pipeline between adjacent flanges, the outside diameters of the plate being turned to fit within the flange bolts. The flanges are either screwed or welded to the pipes.

Applications

- The concentric orifice plate is used to measure flow rates of pure fluids and has a wide applicability as it has been standardized

- The eccentric and segmental orifice plates are used to measure flow rates of fluids containing suspended materials such as solids, oil mixed with water and wet steam.

Advantages

- It is very cheap and easy method to measure flow rate
- It has predictable characteristics and occupies less space
- Can be used to measure flow rates in large pipes

Limitations

- The vena-contracta length depends on the roughness of the inner wall of the pipe and sharpness of the orifice plate. In certain case it becomes difficult to tap the minimum pressure due to the above factor
- Pressure recovery at downstream is poor, that is, overall loss varies from 40 to 90% of the differential pressure.
- In the upstream straightening vanes are a must to obtain laminar flow conditions.
- The orifice plate gets corroded and due to this after sometime, inaccuracy occurs. The coefficient of discharge is low.

5.4.2 Venturi Meter

Venturi tubes are differential pressure producers, based on Bernoulli's Theorem. General performance and calculations are similar to those for orifice plates. In these devices, there is a continuous contact between the fluid flow and the surface of the primary device

It consists of a cylindrical inlet section equal to the pipe diameter, a converging conical section in which the cross sectional area decreases causing the velocity to increase with a corresponding increase in the velocity head and a decrease in the pressure head; a cylindrical throat section where the velocity is constant so that the decreased pressure head can be measured and a diverging recovery cone where the velocity decreases and almost all of the original pressure head is recovered. The unrecovered pressure head is commonly called as head loss.

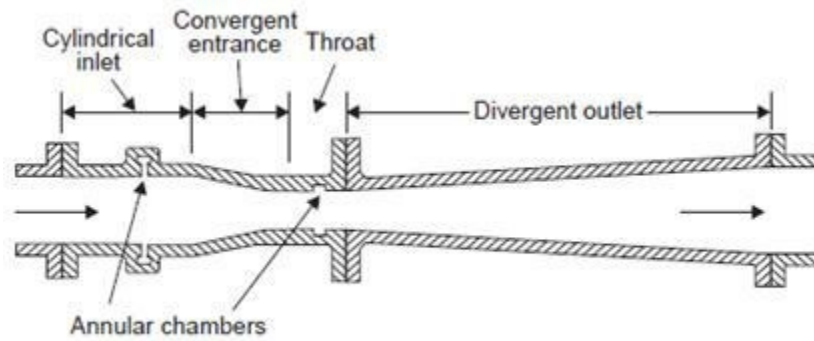

Fig 5.18 Long form Venturi

$$\frac{p_1}{\rho} + \frac{v_1^2}{2} = \frac{p_2}{\rho} + \frac{v_2^2}{2}$$

where

p is pressure (N/m²)

v is velocity (m/s)

ρ is the density of the liquid (kg/m³).

$$\therefore \dot{Q} = \frac{a_1 a_2}{\sqrt{(a_1^2 - a_2^2)}} \sqrt{\frac{2}{\rho} (p_1 - p_2)} \text{ m}^3/\text{s}$$

Limitations $\dot{Q} = a_2 \sqrt{\frac{2(p_1 - p_2)}{\rho(1 - \beta^4)}}$

This flow meter is limited to use on clean, non-corrosive liquids and gases, because it is impossible to clean out or flush out the pressure taps if they clog up with dirt or debris.

Short Form Venturi Tubes

In an effort to reduce costs and laying length, manufactures developed a second generation, or short-form venturi tubes shown in Figure 5.19.

There were two major differences in this design. The internal annular chamber was replaced by a single pressure tap or in some cases an external pressure averaging chamber, and the recovery cone angle was increased from 7

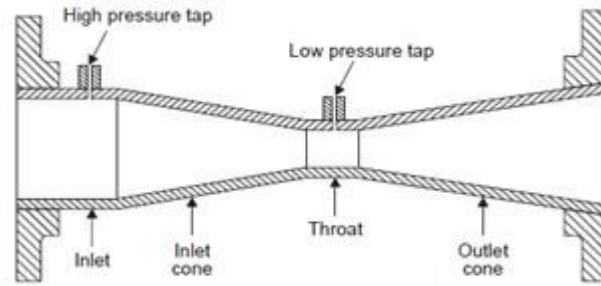

Fig 5.19 Short-form Venturi Tube

degrees to 21 degrees. The short form venturi tubes can be manufactured from cast iron or welded from a variety of materials compatible with the application.

The pressure taps are located one-quarter to one-half pipe diameter upstream of the inlet cone and at the middle of the throat section. A piezometer ring is sometimes used for differential pressure measurement. This consists of several holes in the plane of the tap locations. Each set of holes is connected together in an annular ring to give an average pressure. Venturis with piezometer connections are unsuitable for use with purge systems used for slurries and dirty fluids since the purging fluid tends to short circuit to the nearest tap holes. Piezometer connections are normally used only on very large tubes or where the most accurate average pressure is desired to compensate for variations in the hydraulic profile of the flowing fluid. Therefore, when it is necessary to meter dirty fluids and use piezometer taps, sealed sensors which mount flush with the pipe and throat inside wall should be used. Single pressure tap venturis can be purged in the normal manner when used with dirty fluids. Because the venturi tube has no sudden changes in contour, no sharp corners, and no projections, it is often used to measure slurries and dirty fluids which tend to build up on or clog of the primary devices.

5.4.3 Flow Nozzle

Flange Type Flow Nozzle

The Flow nozzle is a smooth, convergent section that discharges the flow parallel to the axis of the downstream pipe. The downstream end of a nozzle approximates a short tube and has the diameter of the venacontracta of an orifice of equal capacity. Thus the diameter ratio for a nozzle is smaller or its flow coefficient is larger. Pressure recovery is better than that of an orifice. Figure shows a flow nozzle of flange type.

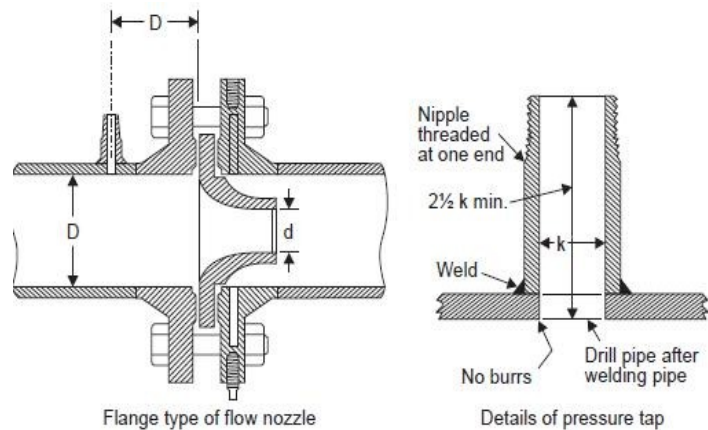

Fig 5.20 Flow Nozzle

Advantages

1. Permanent pressure loss lower than that for an orifice plate.
2. It is suitable for fluids containing solids that settle.
3. It is widely accepted for high pressure and temperature steam flow.

Disadvantages

1. Cost is higher than orifice plate.
2. It is limited to moderate pipe sizes, it requires more maintenance.

5.4.4 Pitot tube

An obstruction type primary element used mainly for fluid velocity measurement is the Pitot tube

Principle

Consider Figure which shows flow around a solid body. When a solid body is held centrally and stationary in a pipeline with a fluid streaming down, due to the presence of the body, the fluid while approaching the object starts losing its velocity till

directly in front of the body, where the velocity is zero. This point is known as the stagnation point. As the kinetic head is lost by the fluid, it gains a static head. By

measuring
of pressure
normal flow
the
point, the
found out.

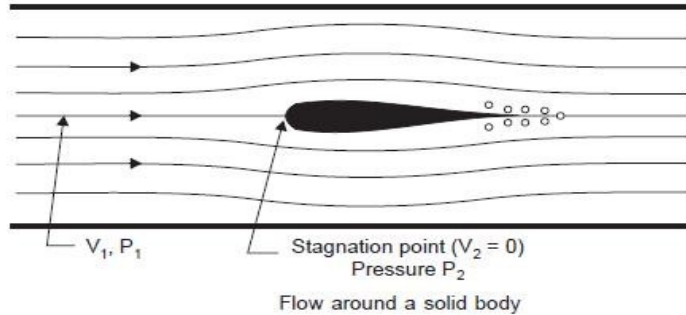

the difference
between that at
line and that at
stagnation
velocity is
This principle

is used in pitot tube sensors.

Fig 5.21 Flow t rough solid body

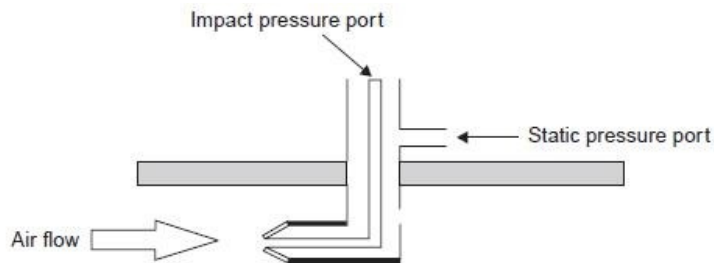

Fig 5.22 Pitot tube

A common industrial type of pitot tube consists of a cylindrical probe inserted into the air stream, as shown in Figure. Fluid flow velocity at the upstream face of the probe is reduced substantially to zero. Velocity head is converted to impact pressure, which is sensed through a small hole in the upstream face of the probe. A corresponding

small hole in the side of the probe senses static pressure. A pressure instrument measures the differential pressure, which is proportional to the square of the stream velocity in the vicinity of the impact pressure sensing hole.

The velocity equation for the pitot tube is given by,

$$v = C_p \sqrt{2gh}$$

Advantages

1. No pressure loss.
2. It is relatively simple.
3. It is readily adapted for flow measurements made in very large pipes or ducts

Disadvantages

1. Poor accuracy.
2. Not suitable for dirty or sticky fluids and fluids containing solid particles.
3. Sensitive to upstream disturbances.

5.4.5 Rotameter

The orificemeter, Venturimeter and flow nozzle work on the principle of constant area variable pressure drop. Here the area of obstruction is constant, and the pressure drop changes with flow rate. On the other hand Rotameter works as a constant pressure drop variable area meter. It can only be used in a vertical pipeline. Its accuracy is also less (2%) compared to other types of flow meters. But the major advantages of rotameter are, it is simple in construction, ready to install and the flow rate can be directly seen on a calibrated scale, without the help of any other device, e.g. differential pressure sensor etc. Moreover, it is useful for a wide range of variation of flow rates (10:1).

The basic construction of a rotameter is shown in figure. It consists of a vertical pipe, tapered downward. The flow passes from the bottom to the top. There is cylindrical type metallic float inside the tube. The fluid flows upward through the gap between the tube and the float. As the float moves up or down there is a change in the gap, as a result changing the area of the orifice. In fact, the float settles down at a position, where the

pressure drop across the orifice will create an upward thrust that will balance the downward force due to the gravity. The position of the float is calibrated with the flow rate.

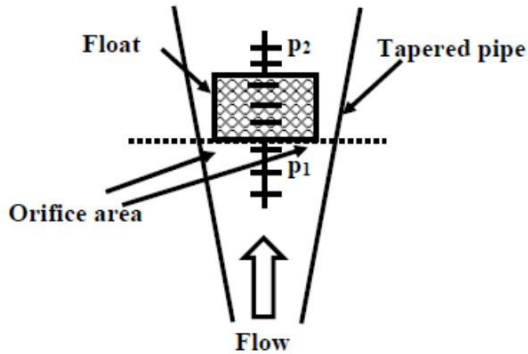

Fig 5.23 Rotameter

γ_1 = Specific weight of the float

γ_2 = specific weight of the fluid

v = volume of the float

A_f = Area of the float.

A_t = Area of the tube at equilibrium (corresponding to the dotted line)

$$Q = \frac{C_d A_2}{\sqrt{1 - \left(\frac{A_2}{A_1}\right)^2}} \sqrt{\frac{2g}{\gamma_2} (p_1 - p_2)}$$

F_d = Downward thrust on the float

F_u = Upward thrust on the float

The major source of error in rotameter is due to the variation of density of the fluid. Besides, the presence of viscous force may also provide an additional force to the float.

Applications

- Can be used to measure flow rates of corrosive fluids
- Particularly useful to measure low flow rates

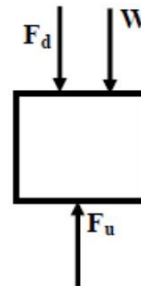

Fig 5.24 Force acting on float

Advantages

- Flow conditions are visible
- Flow rate is a linear function(uniform flow scales)
- Can be used to measure flow rates of liquids, gases and vapour
- By changing the float, tapered tube or both, the capacity of the rotameter can be changed.

Limitations

- They should be installed vertically
- They cannot be used for measurements in moving objects
- The float will not be visible when coloured fluids are used, that is, when opaque fluid are used.
- For high pressure and temperature fluid flow measurements, they are expensive
- They cannot be used for fluids containing high percentage of solids in suspension.

5.5 TEMPERATURE MEASUREMENT

Temperature is one of the most measured physical parameters in science and technology; typically for process thermal monitoring and control. There are many ways to measure temperature, using various principles.

Four of the most common are:

- Mechanical (liquid-in-glass thermometers, bimetallic strips, etc.)
 - Thermojunctive (thermocouples)
- Thermoresistive (RTDs and thermistors)
- Radiative (infrared and optical pyrometers)

5.6 Mechanical Temperature Measuring Devices

A change in temperature causes some kind of mechanical motion, typically due to the fact that most materials expand with a rise in temperature. Mechanical thermometers

can be constructed that use liquids, solids, or even gases as the temperature-sensitive material. The mechanical motion is read on a physical scale to infer the temperature.

5.6.1 Bimetallic strip thermometer

- Two dissimilar metals are bonded together into what is called a bimetallic strip, as sketched to the right.
- Suppose metal A has a smaller coefficient of thermal expansion than does metal B. As temperature increases, metal B expands more than does metal A, causing the bimetallic strip to curl upwards as sketched.
- One common application of bimetallic strips is in home thermostats, where a bimetallic strip is used as the arm of a switch between electrical contacts. As the room temperature changes, the bimetallic strip bends as discussed above. When the bimetallic strip bends far enough, it makes contact with electrical leads that turn the heat or air conditioning on or off.
- Another application is in circuit breakers. High temperature indicates over-current, which shuts off the circuit.
- Another common application is for use as oven, wood burner, or gas grill thermometers. These thermometers consist of a bimetallic strip wound up in a spiral, attached to a dial that is calibrated into a temperature scale.

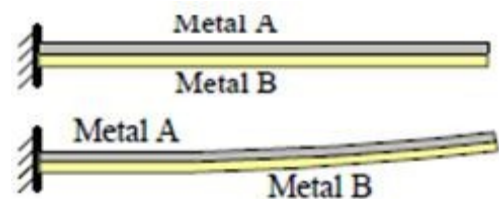

Fig 5.25 Bimetallic Strip

5.6.2 Pressure thermometer

- A pressure thermometer, while still considered mechanical, operates by the expansion of a gas instead of a liquid or solid. There are also pressure thermometers that use a liquid instead of a gas.
 - Suppose the gas inside the bulb and tube can be considered an ideal gas. The ideal gas law is $PV = mRT$, where P is the pressure, V is the volume of the gas, m is the mass
-

of the gas, R is the gas constant for the specific gas (not the universal gas constant), and T is the absolute temperature of the gas.

- Specific gas constant R is a constant. The bulb and tube are of constant volume, so V is a constant. Also, the mass m of gas in the sealed bulb and tube must be constant (conservation of mass).
- A pressure thermometer therefore measures temperature indirectly by measuring pressure.
- The gauge is a pressure gauge, but is typically calibrated in units of temperature instead.
- A common application of this type of thermometer is measurement of outside temperature from the inside of a building. The bulb is placed outside, with the tube running through the wall into the inside.
- The gauge is on the inside. As T increases outside, the bulb temperature causes a corresponding increase in pressure, which is read as a temperature increase on the gauge.

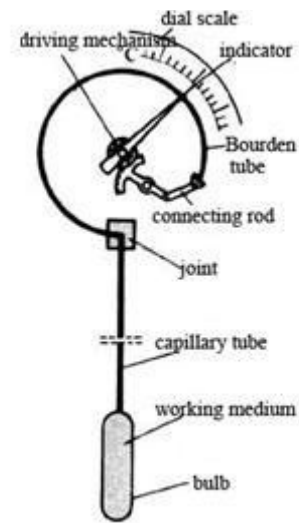

Fig 5.26 Pressure Thermometer

5.7 THERMOCOUPLES (Thermojunctive temperature measuring devices)

Thomas Johan Seebeck discovered in 1821 that thermal energy can produce electric current. When two conductors made from dissimilar metals are connected forming two common junctions and the two junctions are exposed to two different temperatures, a net thermal emf is produced, the actual value being dependent on the materials used and the temperature difference between hot and cold junctions. The thermoelectric emf generated, in fact is due to the combination of two effects: Peltier effect and Thomson effect. A typical thermocouple junction is shown in fig. 5. The emf generated can be approximately expressed by the relationship:

$$e_o = C_1(T_1 - T_2) + C_2(T_1^2 - T_2^2) \mu\text{V}$$

Where, T_1 and T_2 are hot and cold junction temperatures in K. C_1 and C_2 are constants depending upon the materials. For Copper/ Constantan thermocouple, $C_1=62.1$ and $C_2=0.045$.

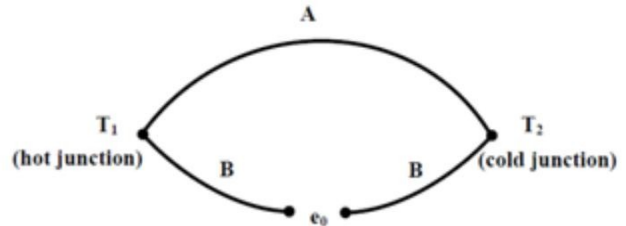

Fig 5.27 Thermocouple

Thermocouples are extensively used for measurement of temperature in industrial situations. The major reasons behind their popularity are:

- (i) They are rugged and readings are consistent
 - (ii) They can measure over a wide range of temperature
 - (iii) Their characteristics are almost linear with an accuracy of about 0.05%.
- However, the major shortcoming of thermocouples is low sensitivity compared to other temperature measuring devices (e.g. RTD, Thermistor).

5.7.1 Thermocouple Materials

Table-1 Thermocouple materials and Characteristics

Type	Positive lead	Negative lead	Temperature range	Temperature coeff.variation $\mu\text{v}/^\circ\text{C}$	Most linear range and sensitivity in the range
R	Platinum-Rhodium (87% Pt, 13% Rh)	Platinum	0-1500°C	5.25-14.1	1100-1500°C 13.6-14.1 $\mu\text{v}/^\circ\text{C}$
S	Platinum-Rhodium (90% Pt, 10% Rh)	Platinum	0-1500°C	5.4-12.2	1100-1500°C 13.6-14.1 $\mu\text{v}/^\circ\text{C}$
K	Chromel (90%Ni, 10% Cr)	Alumel (Ni ₉₄ Al ₂ Mn ₃ Si)	-200-1300°C	15.2-42.6	0-1000°C 38-42.9 $\mu\text{v}/^\circ\text{C}$
E	Chromel	Constantan (57%Cu, 43%Ni)	-200-1000°C	25.1-80.8	300-800°C 77.9-80.8 $\mu\text{v}/^\circ\text{C}$
T	Copper	Constantan	-200-350°C	15.8-61.8	nonlinear
J	Iron	Constantan	-150-750°C	21.8-64.6	100-500°C 54.4-55.9

Theoretically, any pair of dissimilar materials can be used as a thermocouple. But in practice, only few materials have found applications for temperature measurement. The choice of materials is influenced by several factors, namely, sensitivity, stability in calibration, inertness in the operating atmosphere and reproducibility (i.e. the thermocouple can be replaced by a similar one without any recalibration). Table-I shows the common types of thermocouples, their types, composition, range, sensitivity etc. The upper range of the thermocouple is normally dependent on the atmosphere where it has been put. For example, the upper range of Chromel/ Alumel thermocouple can be

increased in oxidizing atmosphere, while the upper range of Iron/ Co sta tan thermocouple can be increased in reducing atmosphere.

5.7.2 Laws of Thermocouple

The Peltier and Thompson effects explain the basic principles of thermoelectric emf generation. But they are not sufficient for providing a suitable measuring technique in actual measuring situations. For this purpose, we have three laws of thermoelectric circuits that provide us useful practical tips for measurement of temperature. These laws are known as law of homogeneous circuit, law of intermediate metals and law of intermediate temperatures. These laws can be explained using figure

The first law can be explained using figure (a). It says that the net thermo-emf generated is dependent on the materials and the temperatures of two junctions only, not on any intermediate temperature.

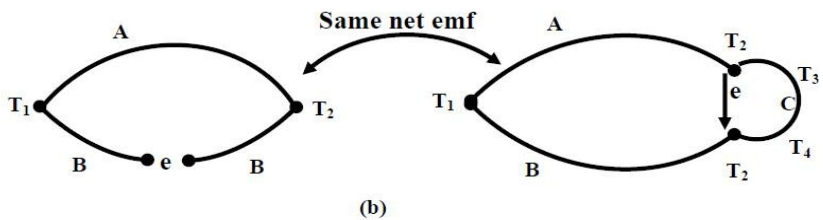
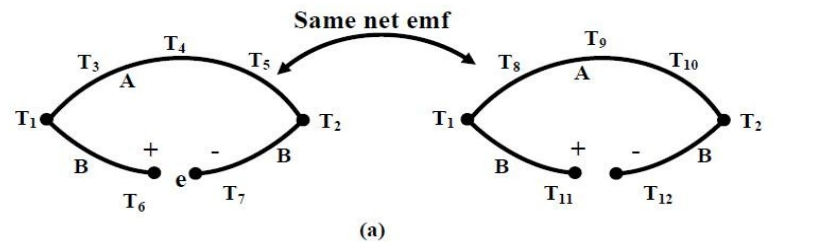

According to the second law, if a third material is introduced at any point (thus forming two additional junctions)

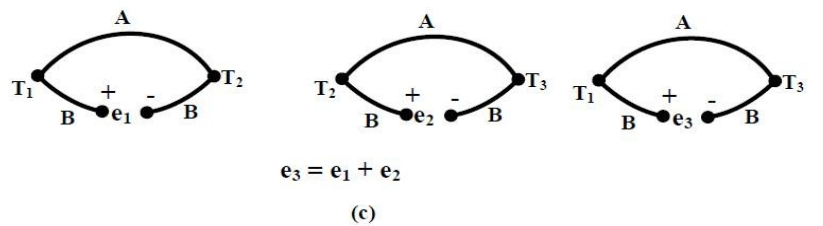

it will not have any effect, if these two additional junctions remain at the same temperatures (figure b). This law makes it possible to insert a measuring device without altering the thermo-emf.

The third law is related to the calibration of the thermocouple. It says, if a thermocouple produces emf e_1 , when its junctions are at T_1 and T_2 , and e_2 when its junctions are at T_2 and T_3 ; then it will generate emf e_1+e_2 when the junction temperatures are at T_1 and T_3 (figure c).

The third law is particularly important from the point of view of reference junction compensation. The calibration chart of a thermocouple is prepared taking the cold or reference junction temperature as 0°C . But in actual measuring situation, seldom the reference junction temperature is kept at that temperature, it is normally kept at ambient temperature. The third law helps us to compute the actual temperature using the calibration chart.

5.8 THERMORESISTIVE TEMPERATURE MEASURING DEVICES

Principle of operation

- A change in temperature causes the electrical resistance of a material to change.
- The resistance change is measured to infer the temperature change.
- There are two types of thermoresistive measuring devices: resistance temperature detectors and thermistors, both of which are described here.

5.8.1 Resistance temperature detectors

A resistance temperature detector (abbreviated RTD) is basically either a long, small diameter metal wire (usually platinum) wound in a coil or an etched grid on a substrate, much like

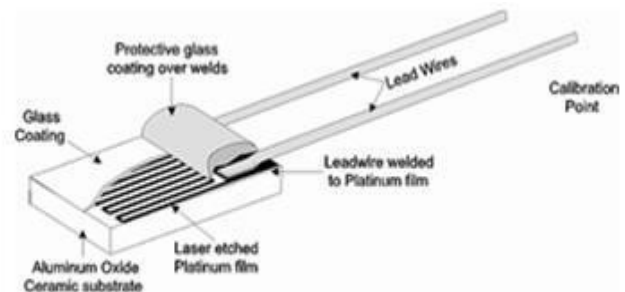
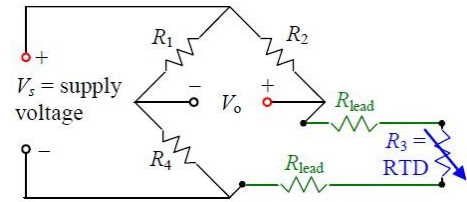

Fig 5.28 RTD

a strain gauge.

The resistance of an RTD increases with increasing temperature, just as the resistance of a strain gauge increases with increasing strain. The resistance of the most common RTD is $100\ \Omega$ at 0°C .



If the temperature changes are large, or if precision is not critical, the RTD resistance can be measured directly to obtain the temperature. If the temperature changes are small, and/or high precision is needed, an electrical circuit is built to measure a change in resistance of the RTD, which is then used to calculate a change in temperature. One simple circuit is the quarter bridge Wheatstone bridge circuit, here called a two-wire RTD bridge circuit.

R_{lead} represents the resistance of one of the wires (called lead wires) that run from the bridge to the RTD itself. Lead resistance is of little concern in strain gauge circuits because R_{lead} remains constant at all times, and we can simply adjust one of the other resistors to zero the bridge.

For RTD circuits, however, some portions of the lead wires are exposed to changing temperatures. Since the resistance of metal wire changes with temperature, R_{lead} changes with T and this can cause errors in the measurement. This error can be non-trivial changes in lead resistance may be misinterpreted as changes in RTD resistance, and therefore give a false temperature measurement.

5.8.2 Thermistors

A thermistor is similar to an RTD, but a semiconductor material is used instead of a metal. A thermistor is a solid state device. Resistance thermometry may be performed using thermistors. Thermistors are many times more sensitive than RTD's and hence are useful over limited ranges of temperature. They are small pieces of ceramic material made by sintering mixtures of metallic oxides of Manganese, Nickel, Cobalt, Copper and Iron etc.

Resistance of a thermistor decreases non-linearly with temperature. Thermistors are extremely sensitive but over a narrow range of temperatures. A

thermistor has larger sensitivity than does an RTD, but the resistance change with temperature is nonlinear, and therefore temperature must be calibrated with respect to resistance. Unlike RTDs, the resistance of a thermistor decreases with increasing temperature. The upper temperature limit of thermistors is typically lower than that of RTD. However, thermistors have greater sensitivity and are typically more accurate than RTDs or thermocouples. A simple voltage divider, where V_s is the supply voltage and R_s is a fixed (supply) resistor. R_s and V_s can be adjusted to obtain a desired range of output voltage V_{out} for a given range of temperature. If the proper value of R_s is used, the output voltage is nearly (but not exactly) linear with temperature. Some thermistors have 3 or 4 lead wires for convenience in wiring – two wires are connected to one side and two to the other side of the thermistor (labeled 1, 2 and 3, 4 above).

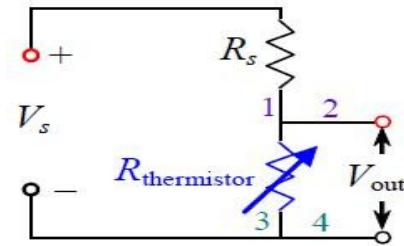

QUESTION BANK

Part-A (2 Marks)

1. What are load cells?
2. Give the principle of hot wire anemometer
3. State any four inferential types of flow meters
4. What is thermopile?
5. Mention the principle involved in bimetallic strip.
6. What is thermocouple?
7. What is a Kentometer?
8. What is the principle involved in fluid expansion thermometer?
9. What is the need of inspection?
10. What are the important elements of measurements?
11. What is the basic Principle of measurement?