



S J P N Trust's

Hirasugar Institute of Technology, Nidasoshi

Inculcating Values, Promoting Prosperity

Approved by AICTE, Recognized by Govt. of Karnataka and Affiliated to VTU Belagavi.

Accredited at 'A' Grade by NAAC

Programmes Accredited by NBA: CSE, ECE, EEE & ME

Mech. Engg. Dept.

Course Plan

VI A and B

2019-20

Department of Mechanical Engineering

COURSE PLAN 2019-20

VI Semester "A and B" division



S J P N Trust's

Hirasugar Institute of Technology, Nidasoshi

Inculcating Values, Promoting Prosperity

Approved by AICTE, Recognized by Govt. of Karnataka and Affiliated to VTU Belagavi.

Accredited at 'A' Grade by NAAC

Programmes Accredited by NBA: CSE, ECE, EEE & ME

Mech. Engg. Dept.

Course Plan

VI A and B

2019-20

INSTITUTE VISION

“To be a preferred institution in Engineering Education by achieving excellence in teaching and research and to remain as a source of pride for its commitment to holistic development of individual and society”

INSTITUTE MISSION

"To continuously strive for the overall development of students, educating them in a state-of-the-art-infrastructure, by retaining the best practices, people and inspire them to imbibe real time problem solving skills, leadership qualities, human values and societal commitments, so that they emerge as competent professionals"

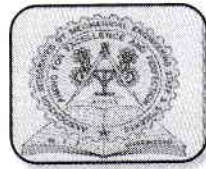

DEPARTMENT OF MECHANICAL ENGINEERING

VISION

“To be the centre of excellence in providing education in the field of Mechanical Engineering to produce technically competent and socially responsible engineering graduates”

MISSION

“Educating students to prepare them for professional competencies in the broader areas of the Mechanical Engineering field by inculcating analytical skills, research abilities and encouraging culture of continuous learning for solving real time problems using modern tools”



S J P N Trust's

Hirasugar Institute of Technology, Nidasoshi

Inculcating Values, Promoting Prosperity
Approved by AICTE, Recognized by Govt. of Karnataka and Affiliated to VTU Belagavi.

Accredited at 'A' Grade by NAAC
Programmes Accredited by NBA: CSE, ECE, EEE & ME

Mech. Engg. Dept.

Course Plan

VI A and B

2019-20

Program Educational Objectives (PEOs)

The Graduates will be able to

- PEO1:** Acquire core competence in Applied Science, Mathematics and Mechanical Engineering fundamentals to excel in professional career and higher study.
- PEO2:** Design, demonstrate and analyze the mechanical systems which are useful to society.
- PEO3:** Maintain professional & ethical values, employability skills, multidisciplinary approach & an ability to realize engineering issues to broader social context by engaging in lifelong learning.

Program Specific Outcomes (PSOs)

- PSO1:** Able to apply the basic principles of Mechanical Engineering in various practical fields to solve societal problems by engaging themselves in many state/national level projects.
- PSO2:** Able to analyze and design basic mechanical system using relevant tools and techniques.
- PSO3:** Able to resolve contemporary issues of industries through industry institute interaction and alumni social networks

Program Outcomes (POs)

- PO1: Engineering knowledge-** Apply the knowledge of mathematics, science, engineering fundamentals, and an engineering specialization to the solution of complex engineering problems.
- PO2: Problem analysis-** Identify, formulate, review research literature, and analyze complex engineering problems reaching substantiated conclusions using first principles of mathematics, natural sciences, and engineering sciences.
- PO3: Design/development of solutions-** Design solutions for complex engineering problems and design system components or processes that meet the specified needs with appropriate consideration for the public health and safety, and the cultural, societal, and environmental considerations.
- PO4: Conduct investigations of complex problems-** Use research-based knowledge and research methods including design of experiments, analysis and interpretation of data, and synthesis of the information to provide valid conclusions.
- PO5: Modern tool usage-** Create, select, and apply appropriate techniques, resources, and modern engineering and IT tools including prediction and modeling to complex engineering activities with an understanding of the limitations.
- PO6: The engineer and society-** Apply reasoning informed by the contextual knowledge to assess societal, health, safety, legal and cultural issues and the consequent responsibilities relevant to the professional engineering practice.
- PO7: Environment and sustainability-** Understand the impact of the professional engineering solutions in societal and environmental contexts, and demonstrate the knowledge of, and need for sustainable development.
- PO8: Ethics-** Apply ethical principles and commit to professional ethics and responsibilities and norms of the engineering practice.
- PO9: Individual and team work-** Function effectively as an individual, and as a member or leader in diverse teams, and in multidisciplinary settings.
- PO10: Communication-** Communicate effectively on complex engineering activities with the engineering community and with society at large, such as, being able to comprehend and write effective reports and design documentation, make effective presentations, and give and receive clear instructions.
- PO11: Project management and finance-** Demonstrate knowledge and understanding of the engineering and management principles and apply these to one's own work, as a member and leader in a team, to manage projects and in multidisciplinary environments.
- PO12: Life-long learning-** Recognize the need for, and have the preparation and ability to engage in independent and life-long learning in the broadest context of technological change.

	S J P N Trust's	Mech. Engg. Dept.
	Hirasugar Institute of Technology, Nidasoshi	Course Plan
	<i>Inculcating Values, Promoting Prosperity</i>	VI A and B
	Approved by AICTE, Recognized by Govt. of Karnataka and Affiliated to VTU Belagavi. Accredited at 'A' Grade by NAAC Programmes Accredited by NBA: CSE, ECE, EEE & ME	2019-20

CONTENTS

Sl. No.	Topic	Page No.
1	Vision and Mission	ii
2	PEOs, PSOs and POs	iii
3	Students Help Desk	v
4	Departmental Resources	vi
5	Teaching Faculty Details	vii
6	Academic Calendar	ix
7	Scheme of Teaching & Examination	x
Theory Course Plan		
1	Finite Element Analysis	17ME61 1 to 08
2	Computer integrated Manufacturing	17ME62 09 to 18
3	Heat Transfer	17ME63 19 to 28
4	Design of Machine Elements -II	17ME64 29 to 48
5	Automobile Engineering	17ME655 49 to 56
6	Total Quality Management	17ME664 57 to 62
Laboratory – Course Plan and Viva Questions		
7	Heat Transfer Lab	17MEL67 63 to 66
8	Modeling and Analysis Lab	17MEL68 67 to 69



S J P N Trust's

Hirasugar Institute of Technology, Nidasoshi

Inculcating Values, Promoting Prosperity
Approved by AICTE, Recognized by Govt. of Karnataka and Affiliated to VTU Belagavi.

Accredited at 'A' Grade by NAAC
Programmes Accredited by NBA: CSE, ECE, EEE & ME

Mech. Engg. Dept.

Course Plan

VI A and B

2019-20

Student Help Desk

S. N.	Additional Responsibility	Contact Person	
		Faculty	Staff
1.	Attestations, Dept. & Institute Work.	HOD	
2.	PG Coordinator/ Research Centre Head	Prof. S A Alur	Sri. V G Badiger
3.	III coordinator (INDUSTRY)	Prof. G A Naik	Sri. R M Hunchyali
4.	III coordinator (INTERNSHIP)	Prof. R. V. Chitgopkar	Sri. S C Jotawar
5.	Class Teachers In-charges	Prof. G A Naik (IV A)	Sri. R B Kumbar
		Prof. M A Hipparagi (IV B)	Sri. M S Kurani
		Prof. M. M. Shivashimpi (VI A)	Sri. R B Kumbar
		Prof. T. S. Vandali (VI B)	Sri. R M Hunchyali
		Prof. S. B. Awade (VIII A)	Sri. S R Nakadi
		Prof. A M Biradar (VIII B)	Sri. S C Jotawar
6.	Record Room Coordinator	Prof. S. B. Awade	Sri. M B Badiger
7.	IA Test Coordinator	Prof. S. B. Awade/Prof. A M Biradar	Sri. M S Kurani
8.	Seminar/Project Coordinator	Prof. N.M.Ukkali/ Prof. B. M. Dodamani	Sri. M B Badiger/ Sri. S C Jotawar
9.	Faculty / AICTE/LIC/ Staff Activities	Prof. B. M. Dodamani	All Instructors
10.	Student Activities/Feedback Coordinator	Prof. Jagdeesh A	
11.	AIMSS Coordinator	Prof. M. M. Shivashimpi/Prof. M R Ingalagi	Sri. M B Badiger
12.	NBA Coordinator	Prof. S. A. Goudadi	
13.	Extra Curricular/ Induction Coordinator	Prof. T S Vandali	
14.	Dept. Meeting Proceedings Coordinator	Prof. K G Ambli	
15.	PhD.EMS/ News Letter Coordinator	Prof. M. M. Shivashimpi	
16.	Choice of Electives	Dr. S. N. Toppannavar	
		Prof. D. N. Inamdar	
		Prof. T. S. Vandali	
17.	EMS Coordinator	Prof. S. B. Awade/ Prof. N.M.Ukkali/ Prof. M R Ingalagi	
18.	TP Cell Coordinator	Prof. R V Nyamagoud	Sri S. R. Nakade
19.	Alumni Coordinator.	Prof. M A Hipparagi	
20.	Robo Vidya Coordinator	Prof. A M Biradar	Sri. V G Badiger
21.	Department Library Coordinator	Sri. Mahantesh Tanodi	Sri. R M Hunchyali
22.	Time Table/ISTE Coordinator	Prof. G. V. Chiniwalar	
23.	GATE Coordinator	H.O.D	
24.	News Letter/ Tech. Magazine/ Coordinator,	Prof. S R Kulkarni/ Prof. M S Futane	
25.	Central Counseling Coordinator (Dept.)	HOD & Class Teachers	
26.	Dispensary	Dr. Arun G. Bullannavar - Cell No. 9449141549	
Institute Level			
01	NBA/NIRF Coordinator	Prof. D. N. Inamdar (9591208980)	
02	Student Welfare Convener	Prof. S. B. Akkole (9480422508)	
03	Hostel warden KSCST Coordinator	Prof. M S Futane (7829611609)	
04	AICTE/ Hostel Asst. Warden Coordinator	Dr. K. M. Akkoli (9739114856)	
05	TP Cell Coordinator	Prof. N. M. Patel (9739619661)	
06	Anti Ragging Convener	Prof. M. S. Futane (9480849334)	
07	Anti Squad Convener	Dr. K. M. Akkoli (9739114856)	
08	Anti Sexual Harassment Convener	Prof. S. S. Kamate (9008696825)	
09	Grievance Redressal Convener	Prof. G. A. Naik (9480539283)	
10	Institute News & publicity	Prof. Mahesh Hipparagi (7411507405)	
11	First Year Coordinator	Dr. S. N. Toppannavar (9945082054)	



Departmental Resources

Department of Mechanical Engineering was established in the year 1996 and is housed in a total area of **2584.5 Sq. Meters.**

Faculty Position

Sl. No.	Category	No. in position	Average experience
1	Teaching faculty	24	17
2	Technical staff	11	14
3	Helper / Peons	05	09

Major Laboratories

S.N.	Name of the laboratory	Area in Sq. Meters	Amount Invested (Rs.)
1	Basic Workshop Laboratory	170	427698
2	Fluid Mechanics Machinery Laboratory	172	775316.75
3	Energy Conversion Engg. Laboratory	173	1269190.2
4	Machine shop Laboratory	170	1361344.5
5	Foundry & Forging Laboratory	179	318787.11
6	Design Laboratory	73	364998
7	Heat & Mass Transfer Laboratory	148	524576
8	Metallography & Material Testing Laboratory	149	1095679.24
9	Mechanical Measurements & Metrology Laboratory	95	548011.75
10	CIM & Automation/CAMA Laboratory	66	3720223.1
11	Computer Aided Machine Drawing Laboratory	66	2013811.5
12	Computer Aided Engg Drawing Laboratory	66	1427271.3
13	Department/Other	--	1908664.2
	Total	1527	1,57,55,571.65



Teaching Faculty Details

S.N.	Faculty Name	Designation	Qualification	Area of specialization	Professional membership	Industry Experience (in years)	Teaching Experience (in years)	Contact Nos.
1	Dr. S. C. Kamate	Principal	Ph. D	Thermal(Cogeneration)	LMISTE	03	27	9480849331
2	Dr. S. A. Alur	Professor	Ph. D	Thermal Power Engg.	LMISTE	--	25	9686856029
3	Dr. B M Shrigiri	HOD/Professor	Ph. D	Thermal Power Engg.	LMISTE	01	21	9741483339
4	Dr. S. N. Topannavar	Assoc. Professor	M Tech.(Ph. D)	Thermal Power Engg.	LMISTE	01	19	9482440235
5	Prof. D. N. Inambar	Asso. Professor	M Tech.(Ph. D)	Tool Engg	LMISTE	08	15	9591208980
6	Dr. K. M. Akkoli	Asso. Professor	M Tech.(Ph. D)	Thermal Power Engg.	LMISTE	1.5	15	9739114856
7	Prof. R.K.Chitgopkar	Asst. Professor	M Tech.	Thermal Power Engg.	LMISTE	1.5	27	9886070475
8	Prof.G. A. Naik	Asst. Professor	M Tech.	Production Management	LMISTE	02	22	9480539283
9	Prof. G. V. Chiniwalar	Asst. Professor	M Tech.	Machine Design	LMISTE	04	15	8762336434
10	Prof.M.S.Futane	Asst. Professor	M Tech.	Computer Integrated Manufacturing	LMISTE	01	13	9164105035
11	Prof. T. S. Vandali	Asst. Professor	M Tech.	Machine Design	LMISTE	8.5	09	9686235904
12	Prof.S. A. Goudadi	Asst. Professor	M Tech.	Design Engineering	LMISTE	--	11	9448876682
13	Sri, S.R. Kulkarni	Asst. Professor	M Tech.	Design Engineering	LMISTE	--	11	8123661692
14	Prof.M.M.Shivashimpi	Asst. Professor	M Tech.(Ph.D)	Thermal Power Engg.	LMISTE	01	09	9742197173
15	Prof. M.A.Hipparagi	Asst. Professor	M Tech.(Ph.D)	Production Technology	LMISTE	02	08	7411507405
16	Prof. A. M. Biradar	Asst. Professor	M Tech.	Machine Design	LMISTE	02	08	9986127703
17	Prof. K. G. Ambli	Asst. Professor	M Tech.(Ph.D)	Product Design and Manufacturing	LMISTE	0.8	07	9164534514
18	Prof. S. B. Awade	Asst. Professor	M Tech.	Machine design	LMISTE		06	9632606108
19	Prof.Mahantesh Tanodi	Asst. Professor	M Tech.	Machine design	LMISTE	--	07	9611998812
20	Prof. N. M. Ukkali	Asst. Professor	M Tech.	Machine Design	LMISTE	--	06	9620152199
21	Prof. M. R. Inagalagi	Asst. Professor	M Tech.	Thermal Power Engg	LMISTE	--	05	9743868503
22	Prof. Jagadeesh A.	Asst. Professor	M Tech.	Thermal Power Engg	LMISTE	--	06	9902847774
23	Prof. R. V. Nyamagoud	Asst. Professor	M Tech.	Thermal Power Engg	LMISTE	--	05	9964822494
24	Prof. B. M. Dodamani	Asst. Professor	M Tech.	Energy System Engg	LMISTE	02	05	9535447575



S J P N Trust's
Hirasugar Institute of Technology, Nidasoshi

Inculcating Values, Promoting Prosperity
 Approved by AICTE, Recognized by Govt. of Karnataka and Affiliated to VTU Belagavi.

Accredited at 'A' Grade by NAAC
 Programmes Accredited by NBA: CSE, ECE, EEE & ME

Mech. Engg. Dept.

Course Plan

VI A and B

2019-20

	S J P N Trust's Hirasugar Institute of Technology, Nidasoshi. <i>Inculcating Values, Promoting Prosperity</i> Approved by AICTE, Recognized by Govt. of Karnataka and Affiliated to VTU Belagavi. Accredited at 'A' Grade by NAAC, Programmes Accredited by NBA: CSE, ECE, EEE & ME.	IQAC File 3-11 2019-20 (Event) Rev: 00
--	--	--

CALENDAR OF EVENTS FOR THE ACADEMIC YEAR 2019-20 (Event)

Date	Events																																																									
18-02-2020	Commencement of IV/VI/VIII Semester Classes	<table border="1"> <tr><td align="center" colspan="7">February-2020</td></tr> <tr><td align="center">S</td><td align="center">M</td><td align="center">T</td><td align="center">W</td><td align="center">T</td><td align="center">F</td><td align="center">S</td></tr> <tr><td></td><td></td><td></td><td></td><td></td><td></td><td>1</td></tr> <tr><td>2</td><td>3</td><td>4</td><td>5</td><td>6</td><td>7</td><td>8</td></tr> <tr><td>9</td><td>10</td><td>11</td><td>12</td><td>13</td><td>14</td><td>15</td></tr> <tr><td>16</td><td>17</td><td>18</td><td>19</td><td>20</td><td>21</td><td>22</td></tr> <tr><td>23</td><td>24</td><td>25</td><td>26</td><td>27</td><td>28</td><td>29</td></tr> </table>	February-2020							S	M	T	W	T	F	S							1	2	3	4	5	6	7	8	9	10	11	12	13	14	15	16	17	18	19	20	21	22	23	24	25	26	27	28	29							
February-2020																																																										
S	M	T	W	T	F	S																																																				
						1																																																				
2	3	4	5	6	7	8																																																				
9	10	11	12	13	14	15																																																				
16	17	18	19	20	21	22																																																				
23	24	25	26	27	28	29																																																				
16-02-2020 to 20-02-2020	II Semester Induction Program																																																									
15-02-2020	Annual Sports Meet																																																									
29-02-2020	Deadline-Vision 2020	20- Maha Shivaratri, 21- Mahadashaha																																																								
14-03-2020	FDP Activities	<table border="1"> <tr><td align="center" colspan="7">March-2020</td></tr> <tr><td align="center">S</td><td align="center">M</td><td align="center">T</td><td align="center">W</td><td align="center">T</td><td align="center">F</td><td align="center">S</td></tr> <tr><td>1</td><td>2</td><td>3</td><td>4</td><td>5</td><td>6</td><td>7</td></tr> <tr><td>8</td><td>9</td><td>10</td><td>11</td><td>12</td><td>13</td><td>14</td></tr> <tr><td>15</td><td>16</td><td>17</td><td>18</td><td>19</td><td>20</td><td>21</td></tr> <tr><td>22</td><td>23</td><td>24</td><td>25</td><td>26</td><td>27</td><td>28</td></tr> <tr><td>29</td><td>30</td><td>31</td><td></td><td></td><td></td><td></td></tr> </table>	March-2020							S	M	T	W	T	F	S	1	2	3	4	5	6	7	8	9	10	11	12	13	14	15	16	17	18	19	20	21	22	23	24	25	26	27	28	29	30	31											
March-2020																																																										
S	M	T	W	T	F	S																																																				
1	2	3	4	5	6	7																																																				
8	9	10	11	12	13	14																																																				
15	16	17	18	19	20	21																																																				
22	23	24	25	26	27	28																																																				
29	30	31																																																								
21-03-2020 to 24-03-2020	First CIE of III/IV/VI/VIII Semester																																																									
28-03-2020	Feedback-1, Submission of Feedback-1 report to office	25- Chandraman Ugadi																																																								
28-03-2020	HSIT SAA@DRAMIA-2020																																																									
11-04-2020	Technical Activities under Professional Bodies	<table border="1"> <tr><td align="center" colspan="7">April-2020</td></tr> <tr><td align="center">S</td><td align="center">M</td><td align="center">T</td><td align="center">W</td><td align="center">T</td><td align="center">F</td><td align="center">S</td></tr> <tr><td></td><td></td><td></td><td>1</td><td>2</td><td>3</td><td>4</td></tr> <tr><td>5</td><td>6</td><td>7</td><td>8</td><td>9</td><td>10</td><td>11</td></tr> <tr><td>12</td><td>13</td><td>14</td><td>15</td><td>16</td><td>17</td><td>18</td></tr> <tr><td>19</td><td>20</td><td>21</td><td>22</td><td>23</td><td>24</td><td>25</td></tr> <tr><td>26</td><td>27</td><td>28</td><td>29</td><td>30</td><td></td><td></td></tr> </table>	April-2020							S	M	T	W	T	F	S				1	2	3	4	5	6	7	8	9	10	11	12	13	14	15	16	17	18	19	20	21	22	23	24	25	26	27	28	29	30									
April-2020																																																										
S	M	T	W	T	F	S																																																				
			1	2	3	4																																																				
5	6	7	8	9	10	11																																																				
12	13	14	15	16	17	18																																																				
19	20	21	22	23	24	25																																																				
26	27	28	29	30																																																						
18-04-2020	HSIT Quest - 2020																																																									
27-04-2020 to 29-05-2020	Second CIE of III/IV/VI/VIII Sem.	06- Mahaveer Jayanti, 10- Good Friday, 14- Dr. B. R. Ambedkar Jayanti																																																								
30-04-2020	Feedback-2, Submission of Feedback-2 report to office																																																									
26-05-2020 to 28-05-2020	Third CIE of III/IV/VI/VIII Sem.	<table border="1"> <tr><td align="center" colspan="7">May-2020</td></tr> <tr><td align="center">S</td><td align="center">M</td><td align="center">T</td><td align="center">W</td><td align="center">T</td><td align="center">F</td><td align="center">S</td></tr> <tr><td></td><td></td><td></td><td></td><td></td><td>1</td><td>2</td></tr> <tr><td>3</td><td>4</td><td>5</td><td>6</td><td>7</td><td>8</td><td>9</td></tr> <tr><td>10</td><td>11</td><td>12</td><td>13</td><td>14</td><td>15</td><td>16</td></tr> <tr><td>17</td><td>18</td><td>19</td><td>20</td><td>21</td><td>22</td><td>23</td></tr> <tr><td>24</td><td>25</td><td>26</td><td>27</td><td>28</td><td>29</td><td>30</td></tr> <tr><td>31</td><td></td><td></td><td></td><td></td><td></td><td></td></tr> </table>	May-2020							S	M	T	W	T	F	S						1	2	3	4	5	6	7	8	9	10	11	12	13	14	15	16	17	18	19	20	21	22	23	24	25	26	27	28	29	30	31						
May-2020																																																										
S	M	T	W	T	F	S																																																				
					1	2																																																				
3	4	5	6	7	8	9																																																				
10	11	12	13	14	15	16																																																				
17	18	19	20	21	22	23																																																				
24	25	26	27	28	29	30																																																				
31																																																										
9-05-2020	Project Exhibition of VIII Semester	01- Labour Day, 25- Qurban-E-Ramzan																																																								
29-05-2020 & 30-05-2020	Lab Internal Assessment of II/IV-VI Semester																																																									
03-06-2020 to 11-06-2020	SEE of VIII Semester (Theory)																																																									
01-06-2020	Last Working Day of IV/VI/VIII Semester																																																									
03-06-2020 to 13-06-2020	Practical Exams of II/IV-VI Semester	<table border="1"> <tr><td align="center" colspan="7">June-2020</td></tr> <tr><td align="center">S</td><td align="center">M</td><td align="center">T</td><td align="center">W</td><td align="center">T</td><td align="center">F</td><td align="center">S</td></tr> <tr><td></td><td></td><td>2</td><td>3</td><td>4</td><td>5</td><td>6</td></tr> <tr><td>7</td><td>8</td><td>9</td><td>10</td><td>11</td><td>12</td><td>13</td></tr> <tr><td>14</td><td>15</td><td>16</td><td>17</td><td>18</td><td>19</td><td>20</td></tr> <tr><td>21</td><td>22</td><td>23</td><td>24</td><td>25</td><td>26</td><td>27</td></tr> <tr><td>28</td><td>29</td><td>30</td><td></td><td></td><td></td><td></td></tr> </table>	June-2020							S	M	T	W	T	F	S			2	3	4	5	6	7	8	9	10	11	12	13	14	15	16	17	18	19	20	21	22	23	24	25	26	27	28	29	30											
June-2020																																																										
S	M	T	W	T	F	S																																																				
		2	3	4	5	6																																																				
7	8	9	10	11	12	13																																																				
14	15	16	17	18	19	20																																																				
21	22	23	24	25	26	27																																																				
28	29	30																																																								
15-06-2020 to 20-07-2020	SEE of II/IV-VI Semester (Theory)																																																									
1 st International Conference 2020, 2 nd week of July, Graduation Day 2020, 2 nd week of July																																																										
 Dr. Shilpa Shingari IQAC Co-ordinator	 Hirasugar Institute of Technology NIDASOSHI 591 236	 Dr. S. K. Kulkarni Hirasugar Institute of Technology NIDASOSHI 591 236																																																								



S J P N Trust's
Hirasugar Institute of Technology, Nidasoshi

Inculcating Values, Promoting Prosperity
Approved by AICTE, Recognized by Govt. of Karnataka and Affiliated to VTU Belagavi.
Accredited at 'A' Grade by NAAC
Programmes Accredited by NBA: CSE, ECE, EEE & ME

Mech. Engg. Dept.

Course Plan

VI A and B

2019-20



S J P N Trust's
Hirasugar Institute of Technology, Nidasoshi.

Inculcating Values, Promoting Prosperity
Approved by AICTE, Recognized by Govt. of Karnataka and Affiliated to VTU Belagavi.
Accredited at 'A' Grade by NAAC, Programmes Accredited by NBA: CSE, ECE, EEE & ME,

MED
Calendar of
Events
2019-20 (Even)
Rev: 00

DEPARTMENT CALENDAR OF EVENTS FOR THE ACADEMIC YEAR 2019-20 (Even)

Date	Events	Calendar																																										
27-01-2020 to 14-02-2020	Training Programme on CATIA and GD&T	February-2020 <table border="1"> <tr><td>S</td><td>M</td><td>T</td><td>W</td><td>T</td><td>F</td><td>S</td></tr> <tr><td></td><td></td><td></td><td></td><td></td><td></td><td>1</td></tr> <tr><td>2</td><td>3</td><td>4</td><td>5</td><td>6</td><td>7</td><td>8</td></tr> <tr><td>9</td><td>10</td><td>11</td><td>12</td><td>13</td><td>14</td><td>15</td></tr> <tr><td>16</td><td>17</td><td>18</td><td>19</td><td>20</td><td>21</td><td>22</td></tr> <tr><td>23</td><td>24</td><td>25</td><td>26</td><td>27</td><td>28</td><td>29</td></tr> </table>	S	M	T	W	T	F	S							1	2	3	4	5	6	7	8	9	10	11	12	13	14	15	16	17	18	19	20	21	22	23	24	25	26	27	28	29
S	M		T	W	T	F	S																																					
							1																																					
2	3		4	5	6	7	8																																					
9	10	11	12	13	14	15																																						
16	17	18	19	20	21	22																																						
23	24	25	26	27	28	29																																						
10-01-2020	Commencement of IV/VI/VIII Semester Classes																																											
28-02-2020	Industrial Visit for 4th Semester																																											
29-02-2020	Books Awarding to Bright Students																																											
07-03-2020	Industrial Visit for 6th Semester	March-2020 <table border="1"> <tr><td>S</td><td>M</td><td>T</td><td>W</td><td>T</td><td>F</td><td>S</td></tr> <tr><td>1</td><td>2</td><td>3</td><td>4</td><td>5</td><td>6</td><td>7</td></tr> <tr><td>8</td><td>9</td><td>10</td><td>11</td><td>12</td><td>13</td><td>14</td></tr> <tr><td>15</td><td>16</td><td>17</td><td>18</td><td>19</td><td>20</td><td>21</td></tr> <tr><td>22</td><td>23</td><td>24</td><td>25</td><td>26</td><td>27</td><td>28</td></tr> <tr><td>29</td><td>30</td><td>31</td><td></td><td></td><td></td><td></td></tr> </table>	S	M	T	W	T	F	S	1	2	3	4	5	6	7	8	9	10	11	12	13	14	15	16	17	18	19	20	21	22	23	24	25	26	27	28	29	30	31				
S	M		T	W	T	F	S																																					
1	2		3	4	5	6	7																																					
8	9		10	11	12	13	14																																					
15	16	17	18	19	20	21																																						
22	23	24	25	26	27	28																																						
29	30	31																																										
13-03-2020	Technical Talk by Industrialist																																											
21-03-2020 to 24-03-2020	First CIE of II/IV/VI/VIII Semester																																											
03-04-2020	Technical Talk by Academician	April-2020 <table border="1"> <tr><td>S</td><td>M</td><td>T</td><td>W</td><td>T</td><td>F</td><td>S</td></tr> <tr><td></td><td></td><td></td><td>1</td><td>2</td><td>3</td><td>4</td></tr> <tr><td>5</td><td>6</td><td>7</td><td>8</td><td>9</td><td>10</td><td>11</td></tr> <tr><td>12</td><td>13</td><td>14</td><td>15</td><td>16</td><td>17</td><td>18</td></tr> <tr><td>19</td><td>20</td><td>21</td><td>22</td><td>23</td><td>24</td><td>25</td></tr> <tr><td>26</td><td>27</td><td>28</td><td>29</td><td>30</td><td></td><td></td></tr> </table>	S	M	T	W	T	F	S				1	2	3	4	5	6	7	8	9	10	11	12	13	14	15	16	17	18	19	20	21	22	23	24	25	26	27	28	29	30		
S	M		T	W	T	F	S																																					
				1	2	3	4																																					
5	6		7	8	9	10	11																																					
12	13	14	15	16	17	18																																						
19	20	21	22	23	24	25																																						
26	27	28	29	30																																								
27-04-2020 to 29-04-2020	Second CIE of II/IV/VI/VIII Sem.																																											
08-05-2020	Hobby Project Competition																																											
26-05-2020 to 28-05-2020	Third CIE of II/IV/VI/VIII Sem.	May-2020 <table border="1"> <tr><td>S</td><td>M</td><td>T</td><td>W</td><td>T</td><td>F</td><td>S</td></tr> <tr><td></td><td></td><td></td><td></td><td></td><td>1</td><td>2</td></tr> <tr><td>3</td><td>4</td><td>5</td><td>6</td><td>7</td><td>8</td><td>9</td></tr> <tr><td>10</td><td>11</td><td>12</td><td>13</td><td>14</td><td>15</td><td>16</td></tr> <tr><td>17</td><td>18</td><td>19</td><td>20</td><td>21</td><td>22</td><td>23</td></tr> <tr><td>24</td><td>25</td><td>26</td><td>27</td><td>28</td><td>29</td><td>30</td></tr> </table>	S	M	T	W	T	F	S						1	2	3	4	5	6	7	8	9	10	11	12	13	14	15	16	17	18	19	20	21	22	23	24	25	26	27	28	29	30
S	M		T	W	T	F	S																																					
						1	2																																					
3	4		5	6	7	8	9																																					
10	11	12	13	14	15	16																																						
17	18	19	20	21	22	23																																						
24	25	26	27	28	29	30																																						
29-05-2020	Project Exhibition of VIII Semester																																											
29-05-2020 to 30-05-2020	Lab Internal Assessment of II/IV/VI Semester																																											
03-06-2020 to 11-06-2020	SEE of VIII Semester (Theory)	June-2020 <table border="1"> <tr><td>S</td><td>M</td><td>T</td><td>W</td><td>T</td><td>F</td><td>S</td></tr> <tr><td></td><td>1</td><td>2</td><td>3</td><td>4</td><td>5</td><td>6</td></tr> <tr><td>7</td><td>8</td><td>9</td><td>10</td><td>11</td><td>12</td><td>13</td></tr> <tr><td>14</td><td>15</td><td>16</td><td>17</td><td>18</td><td>19</td><td>20</td></tr> <tr><td>21</td><td>22</td><td>23</td><td>24</td><td>25</td><td>26</td><td>27</td></tr> <tr><td>28</td><td>29</td><td>30</td><td></td><td></td><td></td><td></td></tr> </table>	S	M	T	W	T	F	S		1	2	3	4	5	6	7	8	9	10	11	12	13	14	15	16	17	18	19	20	21	22	23	24	25	26	27	28	29	30				
S	M		T	W	T	F	S																																					
	1		2	3	4	5	6																																					
7	8		9	10	11	12	13																																					
14	15	16	17	18	19	20																																						
21	22	23	24	25	26	27																																						
28	29	30																																										
01-06-2020	Last Working Day of IV/VI/VIII Semester																																											
03-06-2020 to 13-06-2020	Practical Exams of II/IV/VI Semester																																											
15-06-2020 to 20-06-2020	Project Viva-Voce of VIII Semester																																											
15-06-2020 to 20-07-2020	SEE of II/IV/VI Semester (Theory)																																											

Prof. M.M. Shrivashimpi
AIMSS Co-ordinator

Dr. B. M. Shivam
HOD

Mechanical Engg.
HIT, Nidasoshi



Scheme of Teaching and Examination
6th Semester "A and B" division IV SEMESTER

Sl. No	Subject Code	Title	Teaching Hours /Week			Examination				Credits
			Lecture	Tutorial	Practical	Duration (Hours)	SEE Marks	CIE Marks	Total Marks	
1	17ME61	Finite Element Analysis	3	2	0	03	60	40	100	4
2	17ME62	Computer integrated Manufacturing	4	0	0	03	60	40	100	4
3	17ME63	Heat Transfer	3	2	0	03	60	40	100	4
4	17ME64	Design of Machine Elements - II	3	2	0	03	60	40	100	4
5	17ME65X	Professional Elective-II	3	0	0	03	60	40	100	3
6	17ME66X	Open Elective-II	3	0	0	03	60	40	100	3
7	17MEL67	Heat Transfer Lab	1	0	2	03	60	40	100	2
8	17MEL68	Modeling and Analysis Lab(FEA)	1	0	2	03	60	40	100	2
Total			21	6	4		480	320	60	40

Professional Elective-II		Open Elective-II	
17ME651	Computational Fluid Dynamics	17ME661	Energy Auditing
17ME652	Mechanics of Composite Materials	17ME662	Industrial Safety
17ME653	Metal Forming	17ME663	Maintenance Engineering
17ME654	Tool Design	17ME664	Total Quality Management
17ME655	Automobile Engineering		

- 1. Core subject:** This is the course, which is to be compulsorily studied by a student as a core requirement to complete the requirement of a programme in a said discipline of study.
- 2. Professional Elective:** Elective relevant to chosen specialization/ branch
- 3. Open Elective:** Electives from other technical and/or emerging subject areas.



S J P N Trust's

Hirasugar Institute of Technology, Nidasoshi.

Inculcating values, Promoting Prosperity

Approved by AICTE, Recognized by Govt. of Karnataka and Affiliated to VTU Belagavi.

Accredited at 'A' Grade by NAAC

Programmes Accredited by NBA: CSE, ECE, EEE & ME

Mech Engg. Dept.

Academic

Course Plan

VL A & B
2019-20(Even)

Subject Title	FINITE ELEMENT ANALYSIS		
Subject Code	17ME61	CIE Marks	40
Number of Lecture Hrs / Week	03L+02T	SEE Marks	60
Total Number of Lecture Hrs	50(10 Hours per Module)	Exam Hours	03
CREDITS – 04			

FACULTY DETAILS:

Name: Mr. S A Goudadi	Designation: Asst. Professor	Experience: 12
No. of times course taught: 01	Specialization: Design Engg	

FACULTY DETAILS:

Name: Mr. T S Vandali	Designation: Asst. Professor.	Experience: 18 years
No. of times course taught: 01	Specialization: Machine Design	

1.0 Prerequisite Subjects:

Sl. No	Branch	Semester	Subject
01	Mechanical Engineering	I/II/III/IV	Engg. Mathematics
02	Mechanical Engineering	III	Mechanics of Mechanics
03	Mechanical Engineering	VI	Design of Machine Elements-II
04	Mechanical Engineering	VI	Heat and Mass Transfer

2.0 Course Objectives

- To learn basic principles of finite element analysis procedure.
- To learn the theory and characteristics of finite elements that represent engineering structures.
- To learn and apply finite element solutions to structural, thermal, dynamic problem to develop the knowledge and skills needed to effectively evaluate finite element analyses.

3.0 Course Outcomes

Having successfully completed this course, the student will be able to

CO	Course Outcome	Cognitive Level	POs
CO1	Understand the concepts behind formulation methods in FEM and Choose interpolation polynomial equation for simplex elements	L1,L2	PO1,PO2,PO3,PO6,PO8,PO11,PO12
CO2	Develop element characteristic equation and solve the global equation of FEA elements such as bars and trusses.	L2,L3	PO1,PO2,PO3,PO6,PO8,PO11,PO12
CO3	Develop element characteristic equation and solve the global equation of FEA for beams and circular shafts	L2,L3	PO1,PO2,PO3,PO6,PO8,PO11,PO12
CO4	Develop element characteristic equation and solve the global equation of FEA for 1D heat transfer	L2,L3	PO1,PO2,PO3,PO6,PO8,PO11,PO12
CO5	Develop element characteristic equation and solve the global equation of FEA for axi symmetric and dynamic problems	L2,L3	PO1,PO2,PO3,PO6,PO8,PO11,PO12
Total Hours of instruction			50

**4.0****Course Content****Module I**

Introduction to Finite Element Method : General description of the finite element method. Engineering applications of finite element method. Boundary conditions: homogeneous and no homogeneous for structural, heat transfer and fluid flow problems. Potential energy method, Rayleigh Ritz method, Galerkin's method, Displacement method of finite element formulation. Convergence criteria, Discretisation process, Types of elements: 1D, 2D and 3D, Node numbering, Location of nodes. Strain displacement relations, Stress strain relations, Plain stress and Plain strain conditions, temperature effects.

Interpolation models: Simplex, complex and multiplex elements, Linear interpolation polynomials in terms of global coordinates 1D, 2D, 3D Simplex Elements.

Module II**One-Dimensional Elements-Analysis of Bars and Trusses,**

Linear interpolation polynomials in terms of local coordinate's for 1D, 2D elements. Higher order interpolation functions for 1D quadratic and cubic elements in natural coordinates, Constant strain triangle, Four-Nodded Tetrahedral Element (TET 4), Eight-Nodded Hexahedral Element (HEXA 8), 2D isoparametric element, Lagrange interpolation functions, Numerical integration: Gaussian quadrature one point, two point formulae, 2D integrals. Fore terms: Body force, traction force and point loads,

Numerical Problems: Solution for displacement, stress and strain in 1D straight bars, stepped bars and tapered bars using elimination approach and penalty approach, Analysis of trusses.

Module III

Beams and Shafts: Boundary conditions, Load vector, Hermite shape functions, Beam stiffness matrix based on Euler-Bernoulli beam theory, Examples on cantilever beams, propped cantilever beams, Numerical problems on simply supported, fixed straight and stepped beams using direct stiffness method with concentrated and uniformly distributed load.

Torsion of Shafts: Finite element formulation of shafts, determination of stress and twists in circular shafts.

Module IV

Heat Transfer: Basic equations of heat transfer: Energy balance equation, Rate equation: conduction, convection, radiation, energy generated in solid, energy stored in solid, 1D finite element formulation using vibrational method, Problems with temperature gradient and heat fluxes, heat transfer in composite sections, straight fins.

Module V

Axi-symmetric Solid Elements: Derivation of stiffness matrix of axisymmetric bodies with triangular elements, Numerical solution of axisymmetric triangular element(s) subjected to point loads, angular velocity, pressure vessels.

Dynamic Considerations: Formulation for point mass, Consistent element mass matrix of one dimensional bar element, truss element, axisymmetric triangular element, quadrilateral element, beam element. Lumped mass matrix of bar element, truss element. Evaluation of eigen values and eigen vectors, applications to bars, stepped bars and beams.

5.0**Relevance to future subjects**

Sl No	Semester	Subject	Topics
01	VII	Mechanical Vibrations	Modal Analysis and Harmonic Analysis
02	VIII	Project work	Part Modeling and Analysis

**6.0 Relevance to Real World**

SL.No	Real World Mapping
01	Examples of bars, beams and Trusses
02	Examples of 1D bars for heat transfer

7.0 Books Used and Recommended to Students

Text Books	
1.	Logan, D. L., A first course in the finite element method, 6th Edition, Cengage Learning, 2016.
2.	Rao, S. S., Finite element method in engineering, 5th Edition, Pergaman Int. Library of Science, 2010.
3.	Chandrupatla T. R., Finite Elements in engineering, 2nd Edition, PHI, 2013.
Reference Books	
1.	J.N.Reddy, "Finite Element Method"- McGraw -Hill International Edition. Bathe K. J. Finite Elements Procedures, PHI.
2.	Cook R. D., et al. "Concepts and Application of Finite Elements Analysis"- 4th Edition, Wiley & Sons, 2003.
Additional Study material & e-Books	
1.	NPTEL of FEM and FEA
2.	FEM by ARK Swamy.

8.0 Relevant Websites (Reputed Universities and Others) for Notes/Animation/Videos Recommended

Website and Internet Contents References	
1)	https://en.wikipedia.org/wiki/Finite_element_method
2)	nptel.ac.in/courses/112104116
3)	http://autofem.com/en/examples.html

9.0 Magazines/Journals Used and Recommended to Students

Sl.No	Magazines/Journals	website
1	International Journal of Computational Methods	www.worldscientific.com
2	International Journal of Solids and Structures	http://www.sciencedirect.com/science/journal/00207683

10.0 Examination Note**Internal Assessment: 40 Marks**

Theoretical aspects as well as relevant sketches should be drawn neatly for questions asked in Internal Assessments

Scheme of Evaluation for Internal Assessment

Internal Assessment test in the same pattern as that of the main examination (Average of 3 Tests): 20 marks.

SCHEME OF EXAMINATION:

- Course to be evaluated for 100 marks, irrespective of its Credits.
- One question from each module

INSTRUCTION FOR FINITE ELEMENT METHOD (17ME61) EXAMINATION

- The total duration is 3 hours.
- Draw free hand sketch if required neatly.



11.0 Course Delivery Plan

Unit No.	Lecture No.	Content of Lecture	% of Portion
1	1.	Introduction to Finite Element Method : General description of the finite element method. Engineering applications of finite element method.	20
	2.	Boundary conditions: homogeneous and Non homogeneous for structural, heat transfer and fluid flow problems.	
	3.	Potential energy method, Rayleigh Ritz method, Galerkin's method, Displacement method of finite element formulation	
	4.	Convergence criteria, Discretization process, Types of elements: 1D, 2D and 3D Node numbering,	
	5.	Location of nodes. Strain displacement relations,	
	6.	Stress strain relations, Plain stress and Plain strain conditions, temperature effects	
	7.	Interpolation models: Simplex, complex and multiplex elements,	
	8.	Linear interpolation	
	9.	Polynomials in terms of global coordinates	
	10.	1D, 2D, 3D Simplex Elements.	
2	11.	One-Dimensional Elements-Analysis of Bars and Trusses, Linear interpolation polynomials in terms of local coordinate's for 1D	20
	12.	2D elements, Higher order interpolation functions for	
	13.	1D quadratic and cubic elements in natural coordinates, Constant strain triangle	
	14.	Four-Nodded Tetrahedral Element (TET 4) , Eight-Nodded Hexahedral Element (HEXA 8),	
	15.	2D Iso parametric element, Lagrange interpolation functions,	
	16.	Numerical integration: Gaussian quadrature one point, two point formulae, 2D integrals	
	17.	Force terms: Body force, traction force and point loads,	
	18.	Numerical Problems: Solution for displacement, stress and strain in 1D straight bars,	
	19.	stepped bars and tapered bars using elimination approach and penalty approach ,	
	20.	Analysis of trusses	
3	21.	Beams and Shafts: Boundary conditions, Load vector, Hermite shape functions,	20
	22.	Beam stiffness matrix based on Euler-Bernoulli beam theory,	
	23.	Examples on cantilever beams,	
	24.	propped cantilever beams,	
	25.	Numerical problems on simply supported, fixed straight and	
	26.	stepped beams using direct stiffness method with concentrated and	
	27.	uniformly distributed	
	28.	Torsion of Shafts: Finite element formulation of shafts,	
	29.	Determination of stress and	
4	30.	twists in circular shafts.	20
	31.	Heat Transfer: Basic equations of heat transfer:	
	32.	Energy balance equation,	



	33.	Rate equation: conduction, convection, radiation,			
	34.	energy generated in solid,			
	35.	energy stored in solid,			
	36.	1D finite element formulation using variational method			
	37.	Problems with temperature gradient and			
	38.	Heat fluxes			
	39.	heat transfer in composite sections,			
	40.	straight fins.			
	5	41.		Axi-symmetric Solid Elements: Derivation of stiffness matrix of axisymmetric bodies with	20
		42.		triangular elements	
43.		Numerical solution of axisymmetric triangular element(s) subjected to point loads.			
44.		Angular velocity, Pressure Vessels			
45.		Dynamic Considerations: Formulation for point mass and distributed masses			
46.		Consistent element mass matrix of one dimensional bar element,			
47.		truss element, axisymmetric triangular element, beam element			
48.		Lumped mass matrix of bar element, Truss element, evaluation of eigen values and eigen vectors			
49.		Application to bars, stepped bars and			
50.		beams			

12.0 Assignments, Pop Quiz, Mini Project, Seminars

Sl. No.	Title	Outcome expected: students able to	Allied study	Week No.	Individual / Group activity	Reference : book/web site /Paper
1	Assignment 1: Questions on Introduction to FEM	Understand the concepts behind formulation methods in FEM and Choose interpolation polynomial equation for simplex elements	Module I	2	Individual Activity.	Text Books
2	Assignment 2: Questions on Analysis of bars, trusses	Develop element characteristic equation and solve the global equation of FEA elements such as bars and trusses.	Module II	4	Individual Activity.	Text Books
3	Assignment 3: Questions on Beams and Shafts	Develop element characteristic equation and solve the global equation of FEA for beams and circular shafts	Module III	6	Individual Activity..	Text Books
4	Assignment 4: Questions on heat transfer	Develop element characteristic equation and solve the global equation of FEA for 1D heat transfer	Module IV	8	Individual Activity.	Text Books
5	Assignment 5: Questions on Axi-symmetric Solid Elements, Dynamic Considerations	Develop element characteristic equation and solve the global equation of FEA for axisymmetric and dynamic problems	Module V	10	Individual Activity.	Text Books

**13.0****QUESTION BANK****Module – 1**

1. Write the equilibrium equations in elasticity subjected to body force
2. Write the equilibrium equations in elasticity subjected to traction force
3. Write the stress strain relations for plane stresses and plane strains
4. Write the General description of Finite Element Method
5. Write the Engineering applications of finite element methods
6. Explain different types of elements
7. Explain size of the elements, location of nodes, node numbering scheme
8. Write the Polynomial form of interpolation functions-of linear, quadratic and cubic, Simplex, Complex, Multiplex elements.
9. Explain the Selection of the order of the interpolation polynomial,
10. What is meant by Convergence requirements,
11. What is 2D Pascal triangle
12. Derive an expression for Euler's Lagrange's equations of bar
13. Derive an expression for Euler's Lagrange's equations of beam
14. Derive an expression for Principal of a minimum potential energy,
15. What is meant by principle of virtual work?
16. Explain Rayleigh-Ritz.
17. Derive an expression for Stiffness matrix of bar element by direct method.

Module – 2

1. Write the Linear interpolation polynomials in terms of global coordinates of bar. triangular (2D simplex) elements
2. What is CST element?
3. What is B matrices, Jacobin, Jacobin of 2D triangular element, quad lateral Jacobin of 2D triangular element, quad lateral Consistent load vector
4. What is Higher Order and Isoparametric Elements.
5. Explain the Lagrangian interpolation, Higher order one dimensional elements- quadratic Cubic element their shape functions.
6. Write the Shape functions of 1D quadratic element in natural coordinates
7. Write the shape functions of 1D cubic element shape
8. Write plane trusses by direct stiffness,
9. Explain Solution for displacements reactions.
10. Find the reactions and stresses by using elimination approach
11. Explain penalty approach
12. Using the penalty approach, determine the nodal displacements, stresses and reaction solutions of the axially loaded bar shown in the following Fig. Take $E_{\text{steel}} = 200 \text{ GPa}$, $E_{\text{Al}} = 70 \text{ GPa}$, $A_{\text{steel}} = 16 \text{ mm}^2$, $A_{\text{Al}} = 24 \text{ mm}^2$.

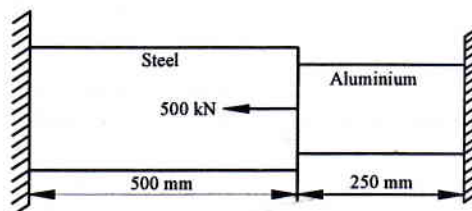

13. Determine the nodal displacements, stresses induced in a stepped bar shown in the following Fig. subjected to thermal loads. Take $E_{\text{steel}} = 200 \text{ GPa}$, $E_{\text{Al}} = 72 \text{ GPa}$, $A_{\text{steel}} = 1000 \text{ mm}^2$, $A_{\text{Al}} = 500 \text{ mm}^2$, $\alpha_{\text{steel}} = 11.7 \times 10^{-6} / ^\circ\text{C}$, $\alpha_{\text{Al}} = 23 \times 10^{-6} / ^\circ\text{C}$, $\Delta T = 60^\circ$.

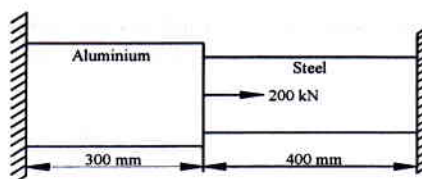

14. Obtain the displacement at node 2 and stresses in the circular solid stepped bar as shown in figure. Take $E_1 = 70 \text{ GPa}$, $E_2 = 200 \text{ GPa}$ for the element 1 and 2 respectively.

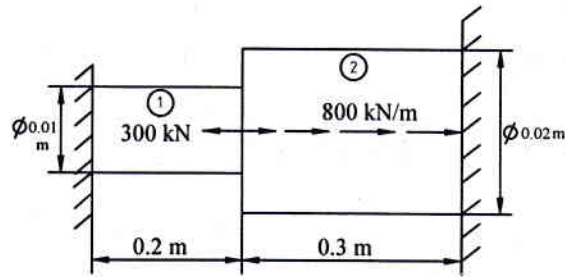

15. Write the properties of shape functions, Truss element.
16. Determine the nodal displacement in the truss segments subjected to concentrated load as shown in Figure. Take $E = 70 \text{ GPa}$, $A = 0.01 \text{ m}^2$.

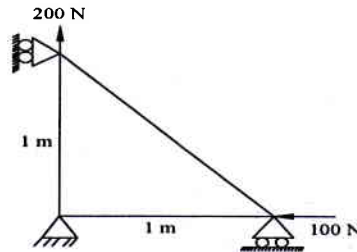

17. Obtain the displacement at node 1, and stresses induced in each member of the truss shown in figure. Take $E = 70 \text{ GPa}$ and $A = 200 \text{ mm}^2$.

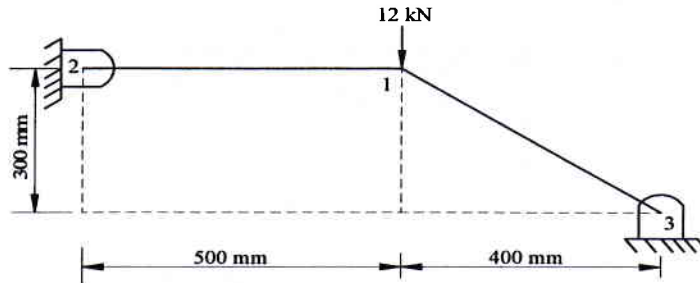

18. For the two member truss shown in figure, determine nodal displacements and stresses in each member. Take $E = 70 \text{ GPa}$ and $A = 100 \text{ mm}^2$.

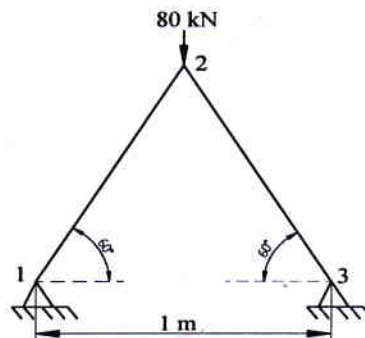

19.

Module – 3

1. Write the Shape function of beam element.
2. Write the Hermite shape function of beam element
3. For the beam shown in the figure, determine the displacement at the centre node. Take $E = 210 \text{ GPa}$, $b = 0.2 \text{ m}$ and $h = 0.4 \text{ m}$.

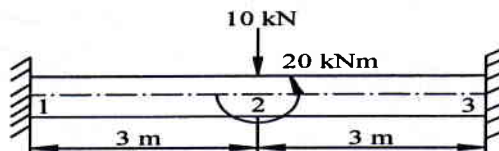

4. Analyse the beam shown in figure, by finite element method and determine the end reactions. Also determine the deflections at mid span of every element. Take $E = 2 \times 10^5 \text{ N/mm}^2$ and $I = 5 \times 10^6 \text{ mm}^4$.

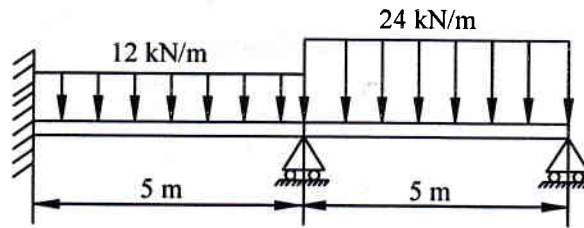

5. Determine the maximum deflection and internal loads in the uniform cross-section of the cantilever beam as shown in the Fig.3. If the beam is treated as a single finite element. Take $E = 70 \times 10^9 \text{ N/m}^2$, $I = 4 \times 10^{-4} \text{ m}^4$.

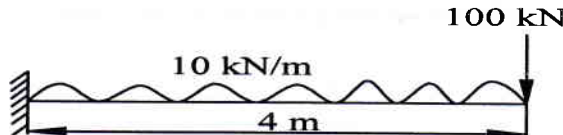

6. Explain Finite element formulation of shafts

Module -4

1. Problems related to beam, heat transfer 1D problems, and convection.
2. Discuss the finite element formulation of circular fin with conduction-convection boundary condition.
3. For the brick wall shown in Fig. 2, the inner surface temperature is 28°C and the outer surface is exposed to cold air at -15°C . Determine the temperature distribution in steady state, within the wall, by considering 2 elements. What is the heat flux through the wall?

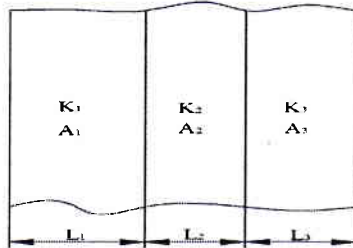

Fig.1

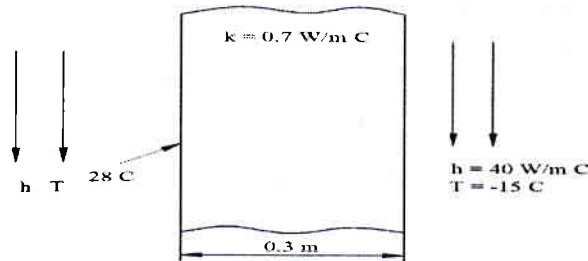
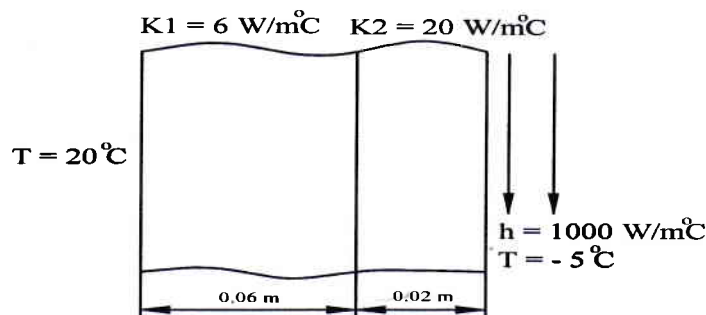

Fig.2

4. Determine the temperature distribution through the composite wall as shown in figure when convection heat loss occurs on the right surface. Assume a unit cross-sectional area.



Module -5

1. What is axisymmetric element? Where do you use?
2. Derive stiffness matrix of axisymmetric triangular element.
3. Derive the stiffness matrix, consistent mass matrix and lumped matrix for 1D bar element

Prepared by	Checked by		
Prof. S. A. Goudadi	Prof. T S Vandali	HOD	Principal



Subject Title	COMPUTER INTEGRATED MANUFACTURING		
Subject Code	17ME62	CIA Marks	40
No of Lecture Hrs + Practical Hrs / Week	04	Exam Marks	60
Total No of Lecture + Practical Hrs	50	Exam Hours	03
CREDITS – 04			

FACULTY DETAILS:

Name: Prof. M S Futane	Designation: Asst. Professor	Experience: 16Years
No. of times course taught: 11 Times	Specialization: Computer Integrated Manufacturing	
Name: Prof. M A Hipparagi	Designation: Asst. Professor	Experience: 11 Years
No. of times course taught: 04	Specialization: Production Technology	

1.0 Prerequisite Subjects:

Sl. No	Branch	Semester	Subject
1	Common to all	I/II	Elements of Mechanical Engg
2	Mechanical Engineering	III/IV	MCW, MCF

2.0 Course Objectives

- To impart knowledge of CIM and Automation and different concepts of automation by developing mathematical models.
- To make students to understand the Computer Applications in Design and Manufacturing [CAD / CAM] leading to Computer integrated systems. Enable them to perform various transformations of entities on display devices.
- To expose students to automated flow lines, assembly lines, Line Balancing Techniques, and Flexible Manufacturing Systems.
- To expose students to computer aided process planning, material requirement planning, capacity planning etc.
- To expose the students to CNC Machine Tools, CNC part programming, and industrial robots.
- To introduce the students to concepts of Additive Manufacturing, Internet of Things, and Industry 4.0 leading to Smart Factory.

3.0 Course Outcomes

Having successfully completed this course, the student will be able to

CO	Course Outcome	Cognitive Level	POs
CO1	Define Automation, CIM, CAD, CAM and explain the differences between these concepts. And Explain the basics of automated manufacturing industries through mathematical models and analyze different types of automated flow lines	L1, L2	PO1,PO6, PO10, PO11, PO12
CO2	Solve simple problems of transformations of entities on computer screen and Categorize CAPP, MRP, PPC and CRP in Manufacturing system	L1,L2, L3	PO2,PO5, PO10, PO12
CO3	Understand the overall FMS and Solve the manual assembly line balancing problem	L2, L3	PO1,PO2,PO3, PO5, PO11, PO12
C04	Explain the use of different computer applications in manufacturing, and prepare part programs for simple jobs on CNC machine tools and robot programming.	L2, L3	PO1,PO2,PO3, PO5, PO10, PO11, PO12
C05	Visualize and appreciate the modern trends in Manufacturing like additive manufacturing, Industry 4.0 and applications of Internet of Things leading to Smart Manufacturing	L1, L2	PO1,PO2,PO3, PO5, PO10, PO11, PO12
Total Hours of instruction			50

**4.0****Course Content****Module - 1****1. Introduction to CIM and Automation:**

Automation in Production Systems, automated manufacturing systems- types of automation, reasons for automating, Computer Integrated Manufacturing, computerized elements of a CIM system, CAD/CAM and CIM. Mathematical models and matrices: production rate, production capacity, utilization and availability, manufacturing lead time, work-in- process, numerical problems. **5 Hours**

2. Automated Production Lines and Assembly Systems: Fundamentals, system configurations, applications, automated flow lines, buffer storage, control of production line, analysis of transfer lines, analysis of flow lines without storage, partial automation, analysis of automated flow lines with storage buffer, fundamentals of automated assembly systems, numerical problems. **5 Hours**

Module – 2

3. CAD and Computer Graphics Software: The design process, applications of computers in design, software configuration, functions of graphics package, constructing the geometry. Transformations: 2D transformations, translation, rotation and scaling, homogeneous transformation matrix, concatenation, numerical problems on transformations. **5 Hours**

4. Computerized Manufacture Planning and Control System: Computer Aided Process Planning, Retrieval and Generative Systems, benefits of CAPP, Production Planning and Control Systems, typical activities of PPC System, computer integrated production management system, Material Requirement Planning, inputs to MRP system, working of MRP, outputs and benefits, Capacity Planning, Computer Aided Quality Control, Shop floor control. **5 Hours**

Module - 3

5. Flexible Manufacturing Systems: Fundamentals of Group Technology and Flexible Manufacturing Systems, types of FMS, FMS components, Material handling and storage system, applications, benefits, computer control systems, FMS planning and design issues, Automated Storage and Retrieval Systems, AS/RS and Automatic parts identification systems and data capture. **5 Hours**

6. Line Balancing: Line balancing algorithms, methods of line balancing, numerical problems on largest candidate rule, Kilbridge and Wester method, and Ranked Positional Weights method, Mixed Model line balancing, computerized line balancing methods. **5 Hours**

Module - 4.

7. Computer Numerical Control: Introduction, components of CNC, CNC programming, manual part programming, G Codes, M Codes, programming of simple components in turning, drilling and milling systems, programming with canned cycles. Cutter radius compensations. **5 Hours**

8. Robot Technology: Robot anatomy, joints and links, common robot configurations, robot control systems, accuracy and repeatability, end effectors, sensors in robotics. Robot programming methods: on-line and off-line methods. Robot industrial applications: material handling, processing and assembly and inspection. **5 Hours**

Module – 5

9. Additive Manufacturing Systems: Basic principles of additive manufacturing, slicing CAD models for AM, advantages and limitations of AM technologies, Additive manufacturing processes: Photo polymerization, material jetting, binder jetting, material extrusion, Powder bed sintering techniques, sheet lamination, direct energy deposition techniques, applications of AM. Recent trends in manufacturing, Hybrid manufacturing. **5 Hours**

10. Future of Automated Factory: Industry 4.0, functions, applications and benefits. Components of Industry 4.0, Internet of Things (IOT), IOT applications in manufacturing, Big-Data and Cloud Computing for IOT, IOT for smart manufacturing, influence of IOT on predictive maintenance, industrial automation, supply chain optimization, supply-chain & logistics, cyber-physical manufacturing systems. **5 Hours**

5.0**Relevance to future subjects**

SL. No	Semester	Subject	Topics / Relevance
01	V	Additive Manufacturing	all
02	VIII	Project Work	Implementation of Mechanisms, automation

**6.0 Relevance to Real World**

SL. No	Real World Mapping
01	Industrial design & mechanisms of various components
02	Various setups for analysis
03	Development of a software applications

7.0 Gap Analysis and Mitigation

Sl. No	Delivery Type	Details
01	Tutorial	Topic: Automated Transfer lines and Assembly system

7.0 Books Used and Recommended to Students**Text Books**

1. Automation, Production Systems and Computer-Integrated Manufacturing, by Mikell P Groover, 4th Edition, 2015, Pearson Learning.
2. CAD / CAM Principles and Applications by P N Rao, 3rd Edition, 2015, Tata McGraw-Hill.
3. CAD/CAM/CIM, Dr. P. Radhakrishnan, 3rd edition, New Age International Publishers, New Delhi.

Reference Books

1. "CAD/CAM" by Ibrahim Zeid, Tata McGraw Hill.
2. "Principles of Computer Integrated Manufacturing", S.Kant Vajpayee, 1999, Prentice Hall of India, New Delhi.
3. "Work Systems And The Methods, Measurement And Management of Work", Groover M. P., Pearson/Prentice Hall, Upper Saddle River, NJ, 2007.
4. "Computer Automation in Manufacturing", Boucher, T. O., Chapman & Hall, London, UK, 1996.
5. "Introduction to Robotics: Mechanics And Control", Craig, J. J., 2nd Ed., Addison-Wesley Publishing Company, Readong, MA, 1989.
6. Internet of Things (IoT): Digitize or Die: Transform your organization. Embrace the digital evolution. Rise above the competition, by Nicolas Windpassinger, Amazon.
7. "Internet of Things: A Hands-on Approach", by Arshdeep Bahga and Vijay Madiseti (Universities Press)
8. Additive Manufacturing Technologies: Rapid Prototyping to Direct Digital Manufacturing, 2nd Ed. (2015), Ian Gibson, David W. Rosen, Brent Stucker
9. "Understanding Additive Manufacturing", Andreas Gebhardt, Hanser Publishers, 2011
10. Industry 4.0: The Industrial Internet of Things, Apress, 2017, by Alasdair Gilchrist

Additional Study material & e-Books

1. Nptel.ac.in
2. VTU, E- learning

8.0 Relevant Websites (Reputed Universities and Others) for Notes/Animation/Videos Recommended**Website and Internet Contents References**

1. <http://www.nptel.ac.in>
2. www.journals.elsevier.com
3. www.youtube.com
4. <https://www.researchgate.net/journal>
5. <https://books.google.co.in/books?isbn>

9.0 Magazines/Journals Used and Recommended to Students



Sl.No	Magazines/Journals	website
1	Robotics and Computer-Integrated Manufacturing - ScienceDirect.com	www.sciencedirect.com/science/journal/07365845
2	Manufacturing, Modelling, Management and Control 2004	https://books.google.co.in/books?isbn=0080445624
3	International Journal of Computer Integrated Manufacturing	www.tandfonline.com/toc/tcim20
4	Computer Integrated Manufacturing	manufacturing-science.asmedigitalcollection.asme.org

10.0 Examination Note

Internal Assessment: 40 Marks

Theoretical aspects as well as relevant sketches should be drawn neatly for questions asked in Internal Assessments

Scheme of Evaluation for Internal Assessment

Internal Assessment test in the same pattern as that of the main examination :40marks.

SCHEME OF EXAMINATION:

There are five modules two questions from each module

Student has to answer any five question choosing at least one questions from each module.

Max. Marks: 100Marks



11.0 Course Delivery Plan

Module No.	Lecture No.	Content of Lecture	% of Portion
1		Introduction to CIM and Automation & Automated Production Lines and Assembly Systems	20
	1	Automation definition, advantages of automation, types of automation.	
	2	Levels of Automation, Automation strategies.	
	3	CIM processing in manufacturing.	
	4	Mathematical Models- CT, Production rate, Production capacity, MLT, WIP, & TIP ratio	
	5	Problems using mathematical models	
	6	Introduction, Automated flow line, objectives	
	7	Flow line configurations, work part transport methods	
	8	Work part transfer mechanisms	
	9	Need for buffer storage, Automation for machining	
	10	Quality, Automation for machining operation	
2		CAD and Computer Graphics Software & Computerized Manufacture Planning and Control System	20
	11	The design process.	
	12	software configuration, functions of graphics package	
	13	Transformations: 2D transformations, translation, rotation and scaling	
	14	homogeneous transformation matrix, concatenation	
	15	numerical problems on transformations	
	16	Velocity Analysis by Instantaneous Center Method: Definition, Kennedy's theorem,	
	17	Introduction, CAPP, Retrieval CAPP	
	18	Generative CAPP, Advantages/Benefits of CAPP, MRP concepts & Terminology	
	19	Structure/Flow chart of MRP, Inputs to MRP	
20	MRP system output, BOM, Parameters in MRP system		
3		Flexible Manufacturing Systems & Line Balancing	20
	21	Fundamentals of Group Technology and Flexible Manufacturing Systems	
	22	types of FMS, FMS components, Material handling and storage system,	
	23	FMS planning and design issues	
	24	Automated Storage and Retrieval Systems, AS/RS	
	25	Automatic parts identification systems and data capture	
	26	Line balancing algorithms	
	27	Different terms involved in Assembly line balancing problem: Precedence diagram, Balance delay, Balance efficiency	
	28	Assembly line balancing by largest candidate rule method	
	29	Assembly line balancing by Kilbridge & Westers method	
30	Assembly line balancing by Ranked positional weight method, computerized line balancing		
4		Computer Numerical Control & Robot Technology	20
	31	NC terminology, Basic components of NC system	
	32	NC coordinate systems. NC motion control systems,	
	33	Applications of NC system, Advantages & Limitations of NC systems	
	34	CNC, need for CNC, different functions of CNC system, Advantages of CNC systems. CNC Machining centres steps in CNC programming.	
	35	Different codes used in the development of NC part programming. The fundamental steps involved in the development of milling part program.	
	36	Basic Robot motions	
	37	Technical features of Robots, Power supply or drive systems for robots	
	38	End effectors, Work cell control	
	39	Robot programming, Robot programming languages	
40	Robot Applications, Application areas for Robots		
5		Additive Manufacturing Systems & Future of Automated Factory	20
	41	Basic principles of additive manufacturing, slicing CAD models for AM, advantages and limitations of AM technologies,	
	42	Additive manufacturing processes: Photo polymerization, material jetting, binder jetting,	



43	material extrusion, Powder bed sintering techniques, sheet lamination,
44	direct energy deposition techniques, applications of AM.
45	Recent trends in manufacturing, Hybrid manufacturing
46	Industry 4.0, functions, applications and benefits
47	Components of Industry 4.0, Internet of Things (IOT), IOT applications in manufacturing,
48	Big-Data and Cloud Computing for IOT, IOT for smart manufacturing,
49	influence of IOT on predictive maintenance, industrial automation,
50	supply chain optimization, supply-chain & logistics, cyber-physical manufacturing system

12.0 Assignments, Pop Quiz, Mini Project, Seminars

Sl.N o.	Title	Outcome expected: students able to	Allied study	Week No.	Individual / Group activity	Reference: book/website /Paper
1	<i>Assignment -1:</i> Questions on Introduction to CIM and Automation & Automated Production Lines and Assembly Systems	Students study the Topics and write the Answers. Get practice to solve university questions.	Module 1	2	Individual Activity.	Books or Website of the Reference list
2	<i>Assignment-2:</i> Questions on CAD and Computer Graphics Software & Computerized Manufacture Planning and Control System	Students study the Topics and write the Answers. Get practice to solve university questions.	Module 2	4	Individual Activity.	Books or Website of the Reference list
3	<i>Assignment-3:</i> Questions on Flexible Manufacturing Systems & Line Balancing	Students study the Topics and write the Answers. Get practice to solve university questions.	Module 3	6	Individual Activity.	Books or Website of the Reference list
4	<i>Assignment-4:</i> Questions on Computer Numerical Control & Robot Technology	Students study the Topics and write the Answers. Get practice to solve university questions.	Module 4	8	Individual Activity.	Books or Website of the Reference list
5	<i>Assignment-5:</i> Questions on Additive Manufacturing Systems & Future of Automated Factory	Students study the Topics and write the Answers. Get practice to solve university questions.	Module 5	8	Individual Activity.	Books or Website of the Reference list

13.0 QUESTION BANK

MODULE-1:

- 1) Define Automation.
- 2) What are the benefits of Automation?
- 3) Differentiate between Fixed Automation & Programmable Automation.
- 4) Explain Flexible Automation, write down its applications.
- 5) Explain the different levels of Automation.
- 6) Briefly explain the Automation strategies.
- 7) Write a note on Automation approach.
- 8) In manufacturing activity how the cycle time is calculated?
- 9) Explain in detail production rate & batch processing time with mathematical equations
- 10) Explanation Production capacity with mathematical equations
- 11) With a neat diagram explain the Information processing in Manufacturing.
- 12) The average part produced in a certain batch manufacturing plant must be processed through an average six machines. 20 new batches are launched each week. Average operation time is 6 min, average set-up time is 5 h, average batch size is 25 parts, and average non-operation time per batch is 10 h/machine. There are 18 machines in the plant. The plant operates an average of 70 production hours per week. Scarp rate is negligible. Determine:



- a) Manufacturing lead time for an average part. b) Production rate c) Plant capacity d) Plant utilization e) WIP f) WIP ratio g) TIP ratio
- 13) A certain part is produced in the batch size of 100 units. The batch must be routed through 5 operations to complete the proceeding of the plant. Average setup time is 3hrs per operation & avg operation time is 6mins. Avg. non-operation time due to handling, delays, inspections etc is 7hrs for each operation. Determine how many days it will take to complete the batch, assuming the plant runs one 8hrs shift per day.
- 14) An average 20 new orders are started each month in a factory. On an avg. an order consist of 50 parts to be processed through 10 m/cs. Avg. Operation time is 15min, avg setup time is 4hrs, average non operation time per order is 8hr per m/c. There are 25 m/c in the plant. 80% of which are operational at any time (20% in repair) the plant operates an average of 160 production hrs per month. However the plant manager complaints that a total of 100 over time m/c hrs must be authorized each month in order to keep up with the production schedule. Determine MLT for an average order, PC & why overtime is authorized, U, average level of WIP, the operation time per m/c for each part=15min.
- 15) Explain the following terms related to manufacturing: i) WIP & TIP ratio, ii) Production rate & MLT, iii) Utilization & Availability.
- 16) Define cycle time, draw the sketch showing all the details, write down the mathematical equation to calculate the cycle time
- 17) How line efficiency of a flow line is calculated?
- 18) What is meant by cost per piece & production rate
- 19) Explain Upper bound approach in detail
- 20) Explain Lower bound approach in detail
- 21) A machine tool builder submits a proposal for a 20 station transfer line to machine a certain component produced by conventional methods. The proposal starts that the line will operates at a production rate of 50 pieces per hour at 100% efficiency. On similar transfer lines, the probability of station break downs per cycle is equal for all stations & $p=0.005$ breakdowns/ cycle. It is also estimated that average down time per line stop will be 8 min. The starting casting that is machined on the line costs \$3 per part. The line operates of \$75 per hour. The 20 cutting tools (one tool per station) last for 50 parts each, & the average cost per tool \$2 per cutting edge. Based on this data, compute i) production rate ii) line efficiency & iii) cost per unit piece produced
- 22) What is meant by blocking or starving in the flow line
- 23) A 10 station automated flow line has 2 stages of 5 stations each. The ideal cycle time of each stage is 1.5min. The average constant down time is 10min. 7 all the stations have the same probability of stopping, which is 0.005. Determine i) line efficiency ii) production rates with buffer storage capacity of a) $b=0$ b) $b= \square$ iii) $b=50$.
- A 20 station transfer flow line is divided into 2 stages of 10 stations each. The ideal cycle of each stage is $T_c=1.2$ min. All of stations in the line have the same probability of stopping, $p=0.005$. We assume the down time is constant when a break down occurs, $T_d=8$ min. Compute the line efficiency for the following buffer capacities I) $b=0$ ii) $b= \square$ iii) $b=10$ iv) $b=100$.
- 24) Using the lower bound approach analyze the transfer lines with & without storage cases.
- 25) With suitable assumptions, determine the line performance for the single & three stages cases.

Station	P_i	Station	P_i
1	0.01	9	0.03
2	0.02	10	0.01
3	0.01	11	0.02
4	0.03	12	0.02
5	0.02	13	0.02
6	0.04	14	0.01
7	0.01	15	0.03
8	0.01	16	0.01

- 26) Give the reasons for the down time, on an automated production line.
- 27) Discuss the limits of storage buffer effectiveness.
- 28) Discuss the starving & blocking of stations with respect to automated flow lines.
- 29) Compare on the basis of cost/ unit & suggest whether the performance of 10 stations transfer line having 6 automated & 4 manual stations with an automated station. Cost for the existing line: i) $C_m = Rs 0.5/$ unit, ii) $T_c = 30$ seconds, iii) $C_o = Rs 0.15/$ minute, iv) $Rs 0.10/$ minute, v) $C_{at} = Rs 0.10/$ minute & vi) $C_t = Rs 0.08/$ minute.
- 30) What is the purpose of buffer storage? Mention 2 extreme cases of buffer effectiveness automated flow lines.
- 31) What are the 2 reasons for partial automation? Analyze the performance of partial automation along the suitable assumptions.
- 32) Differentiate between upper bound & lower bound approach.



MODULE-2:

- 1) Explain in detail functions of graphics package
- 2) What is 2D transformations? Explain the procedure of translation, rotation and scaling
- 3) What is homogeneous transformation matrix
- 4) What is CAPP? Explain briefly.
- 5) Explain Retrieval CAPP with a neat sketch.
- 6) Explain Generative CAPP with a neat sketch.
- 7) Write down the advantages/Benefits of CAPP.
- 8) What is MRP? Explain briefly.
- 9) Explain the important terminology used in MRP.
- 10) Explain with a neat sketch Flow chart of MRP system.
- 11) Explain the main inputs to MRP.
- 12) Sketch the typical MRP report & explain its important uses.
- 13) What is BOM.
- 14) Explain Intended BOM with a block diagram.
- 15) List the parameters of BOM & explain Calculation of demand with an example.
- 16) What is capacity Requirements Planning, How Rated capacity is calculated?
- 17) Explain briefly Long Range Decisions.
- 18) Draw the flow chart showing the details of CRP system.
- 19) Write a note on Infinite & Finite Loading.
- 20) A work centre operates 6 days a week on a 2-shift per day basis with each shift of 8 hrs. It has 5 machines of same capacity. If machines utilized 80% of the time of a system efficiency of 95%, determine the rated capacity in standard hrs/week.

MODULE-3:

- 1) Explain the Fundamentals of Group Technology and Flexible Manufacturing Systems
- 2) Explain in detail types of FMS & FMS components
- 3) What is Automated Storage and Retrieval Systems(AS/RS), explain.
- 4) Explain the procedure of Automatic parts identification systems and data capture
- 5) Define the following with mathematical equations i) Total work content time ii) Work station process time iii) Cycle time iv) line efficiency) Precedence constrains vi) Precedence diagram vii) Balance delay
- 6) Explain the methods with different steps involved in the Assembly line balancing.
- 7) Example with an example any one method of line balancing.
- 8) Write a note on computerized line balancing.
- 9) Explain the reasons for partially automating the production line.
- 10) The table below shows precedence relations & element time for a new part, Ideal cycle time is 10 seconds. Construct the precedence diagram, using all methods, compute the balance delay & line efficiency.

Element No.	Predecessors Element	Time (sec)	Element No.	Predecessors Element	Time (sec)
1	-	5	7	6	2
2	1	3	8	7	6
3	2	4	9	6	1
4	1	3	10	6	4
5	4	6	11	10	4
6	3,5	5	12	8,9,11	7

- 11) Explain with mathematical expression the different terms in line balancing.

MODULE-4:

- 1) Draw the block diagram showing the basic components of NC system & explain each in detail.
- 2) Sketch & explain NC coordinate system for drilling & milling.
- 3) Sketch & explain NC coordinate system for turning.
- 4) Explain fixed zero & floating zero method.
- 5) Explain Absolute coordinate system with a sketch.
- 6) What is NC motion control systems & explain contouring system with a neat sketch.
- 7) List the different Applications of NC system.
- 8) What are the advantages & limitations of NC system?



- 9) What is CNC
- 10) What are the different functions of CNC system & explain Diagnostics in detail.
- 11) Explain vertical machining centre (VMC) with a neat sketch.
- 12) With a block diagram explain the steps involved in part programming.
- 13) What is word address format, briefly explain it.
- 14) Write down the different G & M codes with their function.
- 15) What is canned cycle explain it with an appropriate example.
- 16) Define an industrial Robot.
- 17) Sketch & explain the physical configurations of Robot.
- 18) What is degree of freedom, sketch & explain showing the degrees of freedom of robot.
- 19) Explain point to point method.
- 20) Explain continuous path method.
- 21) Show the different joints in Robot.
- 22) What is degree of freedom, sketch & explain showing the degrees of freedom of robot.
- 23) Explain point to point method .
- 24) Explain continuous path method.
- 25) Show the different joints in Robot.
- 26) Explain the function to be performed by the work cell controller of an industrial robot.
- 27) Explain the basic power sources or drive system of an industrial Robot
- 28) List the important types of sensors used in robot. Explain each in detail.
- 29) Explain briefly what End effector is, sketch & explain the different types of grippers.
- 30) Explain briefly Robot programming.
- 31) List the various Robot programming methods.
- 32) Explain briefly Walkthrough method.
- 33) Write down commonly used monitor commands.
- 34) Write in brief about lead through & offline programming used in Robots.
- 35) Briefly explain General applications of an industrial robot.
- 36) List the different industrial applications of an industrial Robot & explain any 4 applications briefly

MODULE-5:

- 1) What is the Basic principles of additive manufacturing
- 2) List the advantages and limitations of AM technologies
- 3) Explain the process of Photo polymerization, material jetting
- 4) Explain the process of Powder bed sintering techniques, sheet lamination
- 5) Explain the process of binder jetting & direct energy deposition technique
- 6) What is Industry 4.0? Explain its functions.
- 7) List the applications and benefits of Industry 4.0 .
- 8) Explain the Components of Industry 4.0.
- 9) What is Internet of Things (IOT),
- 10) List the IOT applications in manufacturing,
- 11) What is Big-Data and Cloud Computing for IOT,
- 12) Explain in detail the IOT for smart manufacturing,
- 13) What are the influences of IOT on predictive maintenance,
- 14) What is industrial automation?
- 15) What is supply chain management ? optimize it.
- 16) Write a short note on supply-chain & logistics.
- 17) What is cyber-physical manufacturing systems

14.0 University Result

Examination	S+	S	A	B	C	D	E	% Passing
July 2019	00	03	08	16	18	16	4	100
July 2018	01	01	07	14	21	11	3	98.72



S J P N Trust's

Hirasugar Institute of Technology, Nidasoshi.

Inculcating Values, Promoting Prosperity

Approved by AICTE, Recognized by Govt. of Karnataka and Affiliated to VTU Belagavi.

Mech. Engg.

Course Plan

V1 A & B

2019-20 (Even)

Faculty 1: M S Futane

Faculty 2: M A Hipparagi

Module coordinator

HOD

Principal



S J P N Trust's
Hirasugar Institute of Technology, Nidasoshi

Inculcating Values, Promoting Prosperity
 Approved by AICTE, Recognized by Govt. of Karnataka and Affiliated to VTU Belagavi.
Accredited at 'A' Grade by NAAC
Programmes Accredited by NBA: CSE, ECE, EEE & ME.

Mechanical
Course Plan
VI A and B
Even (2019-20)

Subject Title	HEAT TRANSFER		
Subject Code	17ME63	IA Marks	40
Number of Lecture Hrs / Week	03+02	Exam Marks	60
Total Number of Lecture Hrs	50	Exam Hours	03

FACULTY DETAILS:

Name: Dr. K M. Akkoli	Designation: Asst. Professor	Experience:16
No. of times course taught: 10	Specialization: Thermal Power Engineering	

Name: Dr. S. A. Alur	Designation: Professor	Experience:25
No. of times course taught:15	Specialization: Thermal Power Engineering	

1.0 Prerequisite Subjects:

Sl. No	Branch	Semester	Subject
01	Mechanical Engineering	I/II/III/IV	Engg. Mathematics
02	Mechanical Engineering	III	Basic thermodynamics
03	Mechanical Engineering	IV	Applied thermodynamics
04	Mechanical Engineering	IV	Fluid mechanics

2.0 Course Objectives

1. Study the modes of heat transfer.
2. Learn how to formulate and solve 1-D steady and unsteady heat conduction problems.
3. Apply empirical correlations for fully-developed laminar, turbulent internal flows and external boundary layer convective flow problems.
4. Study the basic principles of heat exchanger analysis and thermal design.
5. Understand the principles of boiling and condensation including radiation heat transfer related engineering problems.

3.0 Course Outcomes

Having successfully completed this course, the student will be able to

	Course Outcome	Cognitive Level	POs
C319.1:	Understand the basic modes of heat transfer and determine temperature distribution in steady-state heat conduction.	L2	1,2,3
C319.2:	Understand and interpret heat transfer through extended surfaces and conduct the heat transfer analysis of unsteady-state heat conduction.	L2,L3	1,2,3,4
C319.3:	Interpret and compute forced and free convective heat transfer.	L3,L4	1,2,3
C319.4:	Explain the principles of radiation heat transfer and understand the numerical formula for heat conduction problems.	L3, L4	1,2,3
C319.5:	Design heat exchangers using LMTD and NTU methods.	L3, L4	1,2,3,
Total Hours of instruction		50	

	S J P N Trust's Hirasugar Institute of Technology, Nidasoshi <i>Inculcating Values, Promoting Prosperity</i> Approved by AICTE, Recognized by Govt. of Karnataka and Affiliated to VTU Belagavi. Accredited at 'A' Grade by NAAC Programmes Accredited by NBA: CSE, ECE, EEE & ME.	Mechanical Course Plan VI A and B
		Even (2019-20)

4.0 Course Content

Module – I

Introductory concepts and definitions: Modes of heat transfer: Basic laws governing conduction, convection, and radiation heat transfer; Thermal conductivity; convective heat transfer coefficient; radiation heat transfer combined heat transfer mechanism, Types of boundary conditions. General Heat Conduction Equation: Derivation of the equation in (i) Cartesian, (ii) Polar and (iii) Spherical Co-ordinate Systems. Steady-state one-dimensional heat conduction problems in Cartesian System: Steady-state one-dimensional heat conduction problems (i) with and without heat generation and (ii) with and without varying thermal conductivity - in Cartesian system with various possible boundary conditions, Thermal Resistances in Series and in Parallel.

Module – II

Critical Thickness of Insulation: Concept, Derivation, Extended Surfaces or Fins: Classification, Straight Rectangular and Circular Fins, Temperature Distribution and Heat Transfer Calculations, Fin Efficiency and Effectiveness, Applications

Transient [Unsteady-state] heat conduction: Definition, Different cases - Negligible internal thermal resistance, negligible surface resistance, comparable internal thermal and surface resistance, Lumped body, Numerical Problems, Heisler and Grober charts. Introduction to Numerical analysis of Heat conduction

Module – III

Forced Convection: Boundary Layer Theory, Velocity and Thermal Boundary Layers, Prandtl number, Governing Equations – Continuity, Navier- Stokes and Energy equations, Boundary layer assumptions, Integral and Analytical solutions to above equations, Turbulent flow, Various empirical Solutions, forced convection flow over cylinders and spheres, internal flows –laminar and turbulent flow solutions, Forced Convection Cooling of Electronic Devices.

Free convection: Laminar and Turbulent flows, Vertical Plates, Vertical Tubes and Horizontal Tubes, Empirical solutions.

Module – IV

Thermal Radiation: Fundamental principles - Gray, White, Opaque, Transparent and Black bodies, Spectral emissive power, Wien's, Rayleigh-Jeans' and Planck's laws, Hemispherical Emissive Power, Stefan-Boltzmann law for the total emissive power of a black body, Emissivity and Kirchhoff's Laws, View factor, Net radiation exchange in a two-body enclosure, Typical examples for these enclosures, Radiation Shield.

Module – V

Heat Exchangers: Definition, Classification, applications, LMTD method, Effectiveness - NTU method, Analytical Methods, Fouling Factors, Chart Solution Procedures for solving Heat Exchanger problems: Correction Factor Charts and Effectiveness-NTU Charts, compact heat exchangers.

Heat Transfer with Phase Change: Introduction to boiling, pool boiling, Bubble Growth Mechanisms, Nucleate Pool Boiling, Critical Heat Flux in Nucleate Pool Boiling, Pool Film Boiling, Critical Heat Flux, Heat Transfer beyond the Critical Point, filmwise and dropwise Condensation, heat pipes, entrainment, wicking and boiling limitations.

5.0 Relevance to future subjects

Sl No	Semester	Subject	Topics
01	VII	Hydraulics and pneumatics	Heat transfer in fluids
02	VIII	Power plant engineering	Design of heat transfer equipments

	S J P N Trust's Hirasugar Institute of Technology, Nidasoshi <i>Inculcating Values, Promoting Prosperity</i> Approved by AICTE, Recognized by Govt. of Karnataka and Affiliated to VTU Belagavi. Accredited at 'A' Grade by NAAC Programmes Accredited by NBA: CSE, ECE, EEE & ME.	Mechanical Course Plan VI A and B
		Even (2019-20)

6.0 Relevance to Real World

SL.No	Real World Mapping
01	Solar radiation, Food Cooking
02	Radiators, Heat exchangers
03	Boilers, Condensers

7.0 Books Used and Recommended to Students

Text Books
1. Principals of heat transfer, Frank Kreith, Raj M. Manglik, Mark S. Bohn, Seventh Edition, Cengage learning, 2011.
2. Yunus A. Cengel - Heat transfer, a practical approach, Fifth edition, Tata Mc Graw Hill.
3. J P Holman, Souvik Bhattacharyya, 10 th Edition, McGraw Hill Education Private Ltd.,
Reference Books
1. Heat and mass transfer, Kurt C, Rolle, second edition, Cengage learning.
2. Heat Transfer, M. Necati Ozisik, A Basic Approach, McGraw Hill, New York, 2005.
3. Fundamentals of Heat and Mass Transfer, Incropera, F. P. and De Witt, D. P., 5th Edition, John Wiley and Sons, New York, 2006.
4. Heat Transfer, Holman, J. P., 9th Edition, Tata McGraw Hill, New York, 2008.
Additional Study material & e-Books
1. A Text book of Heat Transfer, John H Lienhard, 4th Edition,
2. NPTEL Heat Transfer course for Mechanical Engineering, http://nptel.ac.in/courses/112101097/
3. Heat Transfer, Chris Long & Naser Sayma, Bookboon.com

8.0 Relevant Websites (Reputed Universities and Others) for Notes/Animation/Videos Recommended

Website and Internet Contents References
1. https://en.wikipedia.org/wiki/Heat_transfer
2. nptel.ac.in/courses/112104116/

9.0 Magazines/Journals Used and Recommended to Students

Sl.No	Magazines/Journals	website
1	International Journal of Heat transfer	https://www.journals.elsevier.com/international-journal-of-heat-and-mass-transfer/
2	International Journal of Thermodynamics	http://dergipark.ulakbim.gov.tr/eoguijt/

10.0 Examination Note

Internal Assessment: 40 Marks

Theoretical aspects as well as relevant sketches should be drawn neatly for questions asked in Internal Assessments

Scheme of Evaluation for Internal Assessment

Internal Assessment test in the same pattern as that of the main examination (Better of the two Tests): 40 marks.

SCHEME OF EXAMINATION:

There are five modules two questions from each module student has to answer any five question choosing at least one questions from each module.



S J P N Trust's
Hirasugar Institute of Technology, Nidasoshi

Inculcating Values, Promoting

Prosperity

Approved by AICTE, Recognized by Govt. of Karnataka and Affiliated to VTU Belagavi.

Accredited at 'A' Grade by NAAC

Programmes Accredited by NBA: CSE, ECE, EEE & ME.

Mechanical

Course Plan

VI A and B

Even (2019-20)

Max. Marks: 60 Marks

11.0 Course Delivery Plan

Module No.	Lecture No.	Content of Lecture	% of Portion
I	1	Introductory concepts and definitions: Modes of heat transfer: Basic laws governing conduction, convection, and radiation heat transfer;	20
	2	Thermal conductivity; convective heat transfer coefficient; radiation heat transfer	
	3	Combined heat transfer mechanism, Types of boundary conditions.	
	4	General Heat Conduction Equation: Derivation of the equation in (i) Cartesian, (ii) Polar and (iii) Spherical Co-ordinate Systems.	
	5	Steady-state one-dimensional heat conduction problems in Cartesian System:	
	6	Steady-state one dimensional heat conduction problems (i) with and without heat generation	
	7	and (ii) with and without varying thermal conductivity - in Cartesian system with various possible boundary conditions,	
	8	Thermal Resistances in Series and in Parallel.	
	9	Numerical	
	10	Numerical	
II	10	Critical Thickness of Insulation: Concept, Derivation,	20
	11	Extended Surfaces or Fins: Classification, Straight Rectangular and Circular Fins,	
	12	Temperature Distribution and Heat Transfer Calculations,	
	13	Fin Efficiency and Effectiveness, Applications	
	14	[Unsteady-state] heat conduction: Definition, Different cases -	
	15	Transient Negligible internal thermal resistance, negligible surface resistance,	
	16	comparable internal thermal and surface resistance, Lumped body,	
	17	Infinite Body and Semi-infinite Body,	
	18	Numerical Problems, Heisler and Grober charts.	
	19	Introduction to Numerical analysis of Heat conduction	
III	21	Forced Convection: Boundary Layer Theory,	20
	22	Velocity and Thermal Boundary Layers, Prandtl number,	
	23	Governing Equations – Continuity, Navier- Stokes and Energy equations,	
	24	Boundary layer assumptions, Integral and Analytical solutions to above equations,	
	25	Turbulent flow, Various empirical Solutions,	
	26	forced convection flow over cylinders and spheres,	
	27	internal flows –laminar and turbulent flow solutions, Forced Convection Cooling of Electronic Devices.	
	28	Free convection: Laminar and Turbulent flows,	
	29	Numerical Problems	
	30	Numerical Problems	
IV	31	Forced Convection: Boundary Layer Theory	



S J P N Trust's
Hirasugar Institute of Technology, Nidasoshi

Inculcating Values, Promoting

Prosperity

Approved by AICTE, Recognized by Govt. of Karnataka and Affiliated to VTU Belagavi.

Accredited at 'A' Grade by NAAC

Programmes Accredited by NBA: CSE, ECE, EEE & ME.

Mechanical

Course Plan

VI A and B

Even (2019-20)

	32	Velocity and Thermal Boundary Layers,	20
	33	Prandtl number, Governing Equations – Continuity, Navier-Stokes and Energy equations,	
	34	Boundary layer assumptions, Integral and Analytical solutions to above equations,	
	35	Various empirical solutions, Forced convection flow over cylinders and spheres,	
	36	Internal flows –laminar and turbulent flow solutions,	
	37	Convection Cooling of Electronic Devices. Free convection: Laminar and Turbulent flows,	
	38	Turbulent flow, Forced Vertical Plates, Vertical Tubes and Horizontal Tubes, Empirical solutions.	
	39		
V	41	Heat Exchangers: Definition, Classification, applications, 9 Hours	20
	42	LMTD method,	
	43	Effectiveness – NTU method, Analytical Methods, Fouling Factors,	
	44	Chart Solution Procedures for solving Heat Exchanger problems:	
	45	Correction Factor Charts and Effectiveness-NTU Charts, compact heat exchangers.	
	46	Heat Transfer with Phase Change: Introduction to boiling, pool boiling,	
	47	Bubble Growth Mechanisms, Nucleate Pool Boiling, Critical Heat Flux in Nucleate Pool Boiling,	
	48	Pool Film Boiling, Critical Heat Flux, Heat Transfer beyond the Critical Point,	
	49	filmwise and dropwise Condensation, heat pipes, entrainment,	
	50	Wicking and boiling limitations.	

12.0 Assignments, Pop Quiz, Mini Project, Seminars

Sl.No.	Title	Outcome expected: students able to	Allied study	Week No.	Individual / Group activity	Reference: book/website /Paper
1	Assignment 1: Questions on Introductory concepts and definitions	Basic definitions and laws	Module-1	2	Individual Activity.	Text Book 1
2	Assignment 2: Questions on Variable thermal conductivity. Questions on One-dimensional transient conduction	Derivations and numerical on variable thermal conductivity Derivations and numerical on one dimensional transient conduction	Module-2	4	Individual Activity.	Text Book 1
3	Assignment 3: Questions on Concepts and basic relations in boundary layers	Boundary layers and free or natural and forced convection	Module-3	6	Individual Activity.	Text Book 1

	S J P N Trust's Hirasugar Institute of Technology, Nidasoshi <i>Inculcating Values, Promoting Prosperity</i>			Mechanical Course Plan VI A and B	
	Approved by AICTE, Recognized by Govt. of Karnataka and Affiliated to VTU Belagavi.				
	Accredited at 'A' Grade by NAAC				
	Programmes Accredited by NBA: CSE, ECE, EEE & ME.				
Even (2019-20)					

4	Assignment 4: Questions on Concepts and basic relations in radiation heat transfer	Radiation heat transfer problems	Module-4	8	Individual Activity.	Text Book 1
5	Assignment 5: Questions on Heat exchangers and Phase Change	Heat exchangers and Phase Change problems	Module-5	10	Individual Activity.	Text Book 1

13.0 QUESTION BANK

MODULE -1

INTRODUCTORY CONCEPTS AND DEFINITIONS

1. Define and explain the different modes of heat transfer.
2. Define thermal conductivity, convection and radiation heat transfer coefficient.
3. Identify modes of heat transfer: Room lighting using tube-lights, water heating using electric heater.
4. What are the different types of boundary conditions? Explain with neat sketches.
5. Derive an expression for the temperature distribution and the rate of heat transfer for a plane, hollow cylinder and sphere.
6. Derive an expression for the rate of heat transfer for composite plane, composite cylinder and sphere.
7. A temperature difference of 500°C is applied across a fireclay brick 10cm thick with thermal conductivity 1.0 W/m°C. Determine the heat transfer rate per square meter area.
8. A temperature difference of 100°C is applied across a cork board 5cm thick with thermal conductivity 0.04 W/m°C. Determine the heat transfer rate across 3-m² area per hour.
9. Obtain expression for 3-D heat conduction equation in Cartesian coordinates.
10. Explain Boundary conditions of first, second and third kinds in heat transfer problems.
11. Water at a mean temperature of 20°C flows over a flat plate at 80°C. If the heat transfer coefficient is 200 W/m² °C, determine heat transfer per square meter of the plate over 5h.
12. A thin metal plate 0.1m by 0.1m is placed in a large evacuated container whose walls are kept at 300K. The bottom surface of the plate is insulated, and the top surface is maintained at 500K as a result of electric heating. If the emissivity of the plate is 0.8, what is the rate of heat exchange between the plate and the walls of the container take $\sigma = 5.67 \times 10^{-8} \text{ W/m}^2 \text{ K}^4$.
13. A small hot surface at a temperature of 430 K with an emissivity of 0.8 dissipates heat by radiation into the surrounding at a temperature of 400 K. If this radiation is characterized by radiation heat transfer coefficient h_r calculate its value.
14. A sphere 10 cm in diameter in a large evacuated chamber whose walls are at 300K. If surface has a emissivity of 0.8 and maintained at 500K, determine the rate of heat loss from the sphere to walls of the chamber take σ as $5.67 \times 10^{-8} \text{ W/m}^2 \text{ K}^4$.

MODULE -2

1. Define the terms Critical thickness of insulation, Fin efficiency, Contact and thermal resistances.
2. A concrete wall of thickness $L_1 = 15 \text{ cm}$ has a thermal conductivity of $k_1 = 0.76 \text{ W/m}^\circ\text{C}$. The inside surface is exposed to air at $T_i = 20^\circ\text{C}$ and the outside surface to air at $T_o = 20^\circ\text{C}$. The heat coefficient for the outside and inside surfaces are $h_1 = 10$ and $h_2 = 40 \text{ W/m}^2\text{C}$. Determine the heat loss per m² of the wall surface.
3. A cylindrical insulation ($k = 0.5 \text{ W/m}^\circ\text{C}$) for a steam pipe has an inside radius of 6cm and an outside radius of 8cm. Determine the heat loss per meter length of pipe if inside and outside surface temperatures of insulation is 430 °C and 30 °C respectively insulation.
4. A 3mm chrome-Nickel wire ($k = 20 \text{ W/m}^\circ\text{C}$) is electrically heated to generate 109 W/m³. If outer surface of the wire is maintained at 100°C, determine temperature at the centre of the wire.
5. Heat is generated at a constant rate of $4 \times 10^8 \text{ W/m}^3$ in a copper wire of radius 0.5 cm and a thermal conductivity of 386 W/m C. The rod is cooled by convection from its cylindrical surface into an ambient at 30°C with a heat transfer coefficient of 2000 W/m² °C. Determine the surface temperature of the rod.
6. Find heat transfer rate through a spherical shell ($r_i = 2 \text{ cm}$, $r_o = 6 \text{ cm}$, $K = 386 \text{ W/m}^\circ\text{C}$) if inner surface is at 200 °C and outer surface is at 100 °C.



S J P N Trust's

Hirasugar Institute of Technology, Nidasoshi

Inculcating Values, Promoting

Prosperity

Approved by AICTE, Recognized by Govt. of Karnataka and Affiliated to VTU Belagavi.

Accredited at 'A' Grade by NAAC

Programmes Accredited by NBA: CSE, ECE, EEE & ME.

Mechanical

Course Plan

VI A and B

Even (2019-20)

7. A wire of 2mm diameter is heated electrically while it dissipates heat to the ambient by convection with heat transfer coefficient $125 \text{ W/m}^2 \text{ }^\circ\text{C}$. If the wire is covered with 0.2mm thick insulation of thermal conductivity $0.175 \text{ W/m}\cdot\text{ }^\circ\text{C}$ will the heat from wire increase or decrease?
8. An electric wire of 3mm diameter is covered with a rubber insulation of thermal conductivity $0.15 \text{ W/m}\cdot\text{ }^\circ\text{C}$. If the ambient air has a heat transfer coefficient of $50 \text{ W/m}^2 \text{ }^\circ\text{C}$ what is the optimum thickness of insulation to produce maximum heat loss from the wire.
9. An electrically heated sphere 6cm diameter is exposed to an ambient at $25 \text{ }^\circ\text{C}$ with a heat transfer coefficient of $20 \text{ W/m}^2 \text{ }^\circ\text{C}$. The surface of sphere is to be maintained at $125 \text{ }^\circ\text{C}$. Calculate the rate of heat loss from the sphere if it is insulated with an insulation ($k=1.0 \text{ W/m}\cdot\text{ }^\circ\text{C}$) corresponding to its critical thickness and when the sphere is bare.
10. Copper plate fins of rectangular cross section having thickness 1mm, height 10mm and thermal conductivity $380 \text{ W/m}\cdot\text{ }^\circ\text{C}$ are attached to a plane wall maintained at $230 \text{ }^\circ\text{C}$. Fins dissipate heat by convection into the ambient air at $30 \text{ }^\circ\text{C}$ with a heat transfer coefficient of $40 \text{ W/m}^2 \text{ }^\circ\text{C}$. Fins are spaced at 8mm (ie 125 fins/m). Assume negligible heat loss from the fin tip to determine fin efficiency, Area weighted fin efficiency. Net rate of heat transfer per m^2 of the wall surface, heat transfer rate without fins.
11. In a cylindrical fuel rod of a nuclear reactor, heat is generated internally according to the equation: where q_g is the local rate of heat generation per unit volume at radius, r , R is the outside radius and q_0 is the rate of heat generation per unit volume at the centerline. Calculate temperature drop from the centerline to the surface for a 25 mm outer diameter fuel rod having thermal conductivity of $25 \text{ W/m}\cdot\text{ }^\circ\text{C}$, if the rate of heat removal from the surface is 1650 kW/m^2 .
12. A cylinder 1 m long and 50 mm in dia is placed in an atmosphere at $45 \text{ }^\circ\text{C}$. It is provided with 12 longitudinal straight fins of material having thermal conductivity $120 \text{ W/m}\cdot\text{ }^\circ\text{C}$. The height of the fins is 12.7 mm from the cylinder and thickness of fins is 0.76 mm. The heat transfer coefficient between cylinder and atmospheric air is $17 \text{ W/m}^2 \text{ }^\circ\text{C}$. Calculate the rate of heat transfer and the temperature at the end of the fins if surface temperature of the cylinder is $150 \text{ }^\circ\text{C}$. Assume the tip of the fin to be insulated. (Neglect the circular plane surface on either side)
13. What do you mean by Lumped System Analysis? Obtain an expression for temperature distribution for this system in terms of Biot and Fourier numbers.
14. Define Biot and Fourier number. Explain their significance.
15. For a semi-infinite solid write the different boundary conditions for transient heat conduction with neat sketches.
16. A solid copper sphere of 10cm diameter [$\rho=8954 \text{ kg/m}^3$, $C_p=383 \text{ J/kg}\cdot\text{ }^\circ\text{C}$, $k=386 \text{ W/m}\cdot\text{ }^\circ\text{C}$] initially at a uniform temperature of $250 \text{ }^\circ\text{C}$ is suddenly immersed in a well stirred fluid which is maintained at a uniform temperature of $50 \text{ }^\circ\text{C}$. The heat transfer coefficient of the fluid and sphere is $200 \text{ W/m}^2 \text{ }^\circ\text{C}$. Check if the lumped system analysis is suitable and hence determine the temperature of the block $t=5, 10, 15$ min after the immersion (Ans= $120, 74.5$ & $53 \text{ }^\circ\text{C}$).
17. Using the lumped analysis determine the time required for the solid steel [$\rho=7833 \text{ kg/m}^3$, $C_p=0.46 \text{ kJ/kg}\cdot\text{ }^\circ\text{C}$, $k=54 \text{ W/m}\cdot\text{ }^\circ\text{C}$] sphere of 5cm diameter to cool from $600 \text{ }^\circ\text{C}$ to $200 \text{ }^\circ\text{C}$ if it is exposed to air stream at $50 \text{ }^\circ\text{C}$ having a heat transfer coefficient of $100 \text{ W/m}^2 \text{ }^\circ\text{C}$ (Ans= 6min 34 S).
18. A 12mm diameter mild steel sphere ($K=42.5 \text{ W/m}\cdot\text{ }^\circ\text{C}$) is placed in an air stream at $27 \text{ }^\circ\text{C}$ and the corresponding heat transfer coefficient is $114 \text{ W/m}^2 \text{ }^\circ\text{C}$. Calculate time taken to cool sphere from $540 \text{ }^\circ\text{C}$ to $95 \text{ }^\circ\text{C}$ and Instantaneous heat transfer rate two minutes after commencement of cooling. For mild steel: Density= 7850 kg/m^3 Sp. heat= $475 \text{ J/kg}\cdot\text{ }^\circ\text{C}$ Thermal diffusivity= $0.043 \text{ m}^2/\text{hr}$.
19. A 0.10m thick brick wall ($\alpha=0.5 \times 10^{-6} \text{ m}^2/\text{s}$, $k=0.69 \text{ W/m}\cdot\text{ }^\circ\text{C}$ and $\rho=2300 \text{ kg/m}^3$) is initially at $T_i=230 \text{ }^\circ\text{C}$. The wall is suddenly exposed to an environment at $T_\infty=30 \text{ }^\circ\text{C}$ with a heat transfer coefficient $h=60 \text{ W/m}^2 \text{ }^\circ\text{C}$. By using the transient temperature charts, Determine the centre temperature at 0.5, 2 and 4h after exposure to the cooler ambient, surface temperature at 0.5 and 2h, and Energy removed from the plate per square meter during 0.5h.
20. A long 8cm diameter chrome-steel rod ($\alpha=1.1 \times 10^{-5} \text{ m}^2/\text{s}$ and $k=40 \text{ W/m}\cdot\text{ }^\circ\text{C}$) is initially at a uniform temperature $T_i=225 \text{ }^\circ\text{C}$. It is suddenly exposed to a convective environment at $T_\infty=25 \text{ }^\circ\text{C}$ with a surface heat transfer coeff. $h=50 \text{ W/m}^2 \text{ }^\circ\text{C}$. Using transient temperature chart, determine temperature at centre, surface temperature at $t=1/10$ and 1h after exposure to cooler ambient.

MODULE -3

1. Explain the thermal boundary layer. Distinguish between developing and developed hydrodynamic flow through pipes.
2. Derive expressions for drag force and lift force.
3. Explain Reynolds Colburn analogy.
4. Determine the thickness of thermal boundary layer, local drag coefficient and local shear stress at a distance of 0.5 m from the leading edge of a flat plate for the boundary layer flow of air at $77 \text{ }^\circ\text{C}$ and a velocity of 2 m/s .
5. Determine drag force exerted on a 2m long plate per 1m width of flow with air hydrogen and helium as fluids, at atmospheric pressure and $350 \text{ }^\circ\text{C}$ with a velocity of 5 m/s .
6. Atmospheric air at $27 \text{ }^\circ\text{C}$ flows with a free stream velocity of 10 m/s along a flat plate 4m long. Compute the drag coefficient at 2 and 4m from the leading edge. Assume an all turbulent boundary layer, determine the drag force



S J P N Trust's

Hirasugar Institute of Technology, Nidasoshi

Inculcating Values, Promoting

Prosperity

Approved by AICTE, Recognized by Govt. of Karnataka and Affiliated to VTU Belagavi.

Accredited at 'A' Grade by NAAC

Programmes Accredited by NBA: CSE, ECE, EEE & ME.

Mechanical

Course Plan

VI A and B

Even (2019-20)

exerted per 1m width of plate.

- Air at 0.6 atm and -15°C flows with a free stream velocity of 120m/s over the wing of an airplane. The wing is 2m long in the direction of flow and can be regarded as a flat plate. Determine the local drag coefficient and the shear stress at the trailing edge of the wing. What is the drag force per meter width of the wing?
- Determine the thickness of the thermal boundary layer and the local heat transfer coefficient at a distance of 1m from the leading edge of a flat plate for the flow of air at 77°C and velocity 4m/s at pressures of 0.5, 1.0 and 2 atmosphere
- Explain Hydrodynamic and thermal boundary layer with reference to flow over flow heated plate.
- Explain the following Dimensionless number and their physical significance:
- Reynolds number, (ii) Prandtl number, (iii) Nusselt number
- Write short notes on (any two):
 - Biot number and Fourier and their significance.
 - Hydrodynamic and Thermal boundary layer
4. Water at the rate of 3kg/s is heated from 5 to 15°C by passing it through a 50 mm ID copper tube. The tube wall temperature is maintained at 90°C . What is the tube length?
- Air at 30°C is flowing over 2 cm long plate maintained at 70°C at m/s. Determine heat transfer from the plate.
6. A highly viscous fluid flows through a 5 cm I.D. pipe at rate 50 kg/hr. Fluid passes through 1 m long heated section where a constant flux of 1000 W/m^2 is supplied. Calculate the final temperature of liquid if initial temperature is 40°C . Obtain the maximum wall temperature. Assume properties of liquid as, $P = 1500 \text{ kg/m}^3$,
- $C_p = 1.675 \text{ kJ/kg K}$, $k_s = 0.865 \text{ W/mK}$.
- Water at 20°C is to be heated by passing it through the tube. Surface of tube is maintained at 90°C . The diameter of tube is 4 cm while its length is 9 m. Find the mass flow rate so that exit temperature of water will be 60°C . The properties of water are $\rho = 995 \text{ kg/m}^3$, $C_p = 4.175 \text{ kJ/kg K}$, $K = 0.64 \text{ W/mK}$, $V = 0.62 \times 10^{-6} \text{ m}^2/\text{s}$, $B = 4.25 \times 10^{-3} \text{ K}^{-1}$. Use the correlation $Nu = 0.023 * (Re)^{0.8} . (Pr)^{0.3}$
8. In a certain process, castor oil at 30°C flows past a flat plate. The velocity of oil is 0.08 m/sec. The length of the plate is 5 m. The plate is heated uniformly and maintained at 90°C . Calculate the following: (i) Hydrodynamic and thermal boundary layer thickness at the trailing edge of plate. (ii) Total drag force per unit width on one side of the plate. Use the following correlation: $Nu = 0.332 (Re)^{1/2} . (Pr)^{1/3}$ Take properties as, $P = 956.8 \text{ kg/m}^3$, $k = 0.213 \text{ W/mK}$, $\alpha = 7.2 \times 10^{-8} \text{ m}^2/\text{s}$, $\nu = 0.65 \times 10^{-4} \text{ m}^2/\text{s}$
9. In a particular solar collector of cylindrical type, energy is collector by placing a tube at the focal line of parabolic collector and passing fluid through the tube. The arrangement resulting is a uniform heat flux of 2000 W/m^2 along the axis of the tube of diameter 60 mm. Determine: (i) Length of the tube required to the heat water
- from 20°C to 80°C which flows at the rate of 0.01 kg/s. (ii) Surface temperature at the outlet Properties of water are: $\mu = 352 \times 10^{-6} \text{ Ns/m}^2$, $C_p = 4187 \text{ J/kg K}$, $k = 0.67 \text{ W/mK}$.

MODULE -4

- Explain the following laws as applied to radiation: i) Stefan Boltzman law ii) Plank's Distribution law iii) Wein's Displacement law iv) Kirchoff's law.
- Determine the radiative energy emitted between 2-10 μm wavelengths by a 1x1m grey surface at 600 K which has an emissivity of 0.8.
- A tungsten filament is heated to 2300K. What fraction of the total energy is emitted in the wave length range of 0.4 to 0.8 μm ?
- A black body at 1111K is emitting into air. Calculate the wavelength at which black body emissive power is maximum and energy emitted over wave length limits 1-10 μm and 10-20 μm
- A small surface of area 8 cm² is subjected to radiation of constant intensity $I=105 \text{ W/m}^2$. Sr over a solid angle subtended by $0 \leq \phi \leq 2\pi$, $0 \leq \theta \leq \pi/3$. Calculate energy emitted by surface.
- Determine average emissivity of filament at 3000K for entire wavelengths using given data $\epsilon_1 = 0.5$ for $\lambda_0 = 0$ to $\lambda_1 = 0.5 \mu\text{m}$ $\epsilon_2 = 0.1$ for $\lambda_1 = 0.5$ to $\lambda_2 \rightarrow \infty$
- Calculate the heat dissipated by radiation through a 0.2-m² opening of a furnace at 1100K into an ambient at 300K. Assume both the furnace and the ambient to be black bodies.
- A radiation shield having equal emissivities on both surfaces is placed between two large parallel plates one at T_1 K and other at T_2 K with emissivities of 0.8 and 0.5 respectively. Sketch the radiation network and determine the emissivity of the shield in order to reduce the heat transfer between the plates to 8% of that without the radiation shield. Two very large parallel planes with emissivities 0.3 and 0.8 exchange heat. Find the percentage reduction in heat transfer when a polished aluminum radiation shield (is placed between them.

MODULE -5

- Give the classification of heat exchangers based on flow and mode of heat exchanger.
- Derive an expression for LMTD for a Parallel and Counter flow heat exchanger.



3. Derive an expression for Effectiveness for a Parallel and Counter flow heat exchanger.
4. A copper pipe ($K=350 \text{ w/mk}$) of 17.5mm inner diameter and 20mm outside diameter conveys water and oil flows through the annular passage between this pipe and a steel pipe. On the water side, the film co-efficient is $4600 \text{ w/m}^2\text{k}$ and the fouling factor is $0.00034 \text{ m}^2\text{k/w}$. The corresponding values for the oil side are $1200 \text{ w/m}^2\text{k}$ and $0.00086 \text{ m}^2\text{k/w}$. Calculate the overall heat transfer coefficient between the water and oil, based on outside surface area of inner pipe.
5. A shell and tube heat exchanger is to cool oil ($C_p=2000 \text{ J/kgk}$) flowing at 6 kg/s from 65°C to 35°C by using water of 10 kg/s flow rate with inlet temperature 20°C . Average heat transfer coefficient $U_m=600 \text{ w/m}^2\text{k}$. Calculate heat transfer area for a parallel flow and counter flow arrangement.
6. Steam condenses at 60°C on shell side of a steam condenser while cooling water flows inside tubes at 3 kg/s . The inlet and outlet temperatures of water are 20°C and 50°C respectively. The overall heat transfer coefficient $U_m=2000 \text{ w/m}^2\text{k}$. Calculate the surface area required.
7. A single pass cross-flow heat exchanger is used to heat water from 25°C to 80°C at a rate of 1.5 kg/s with pressurized water entering the tubes at 200°C and leaving at 100°C . The overall heat transfer coefficient $U_m=1250 \text{ w/m}^2\text{k}$. Calculate the heat transfer area taking $C_{pc}=4180 \text{ J/kg}^\circ\text{C}$.
8. A counter flow heat exchanger is to heat air entering at 400°C (flow rate 6 kg/s) with an exhaust gas entering at 800°C (flow rate 4 kg/s). Overall heat transfer coefficient $U_m=100 \text{ w/m}^2\text{k}$, specific heat for both air and exhaust gas: $C_{pc} = C_{ph} = 1100 \text{ J/kg}^\circ\text{C}$. Calculate heat transfer area required if the heat transfer rate is 1000 kW . Also determine outlet temperatures of exhaust gas and air.
9. Engine oil is to be cooled from 80°C to 50°C by using a single pass counter flow concentric tube heat exchanger with cooling water available at 20°C . Water flows inside a 25mm dia at a rate of 0.08 kg/s and oil flows through the annulus at a rate of 0.16 kg/s . The heat transfer coefficient for the water side and oil side are $1000 \text{ W/m}^2 \text{ K}$ and $80 \text{ W/m}^2 \text{ K}$ respectively. The fouling factors are $0.00018 \text{ m}^2 \text{ K/W}$ on the water side and $0.00018 \text{ m}^2 \text{ K/W}$ on oil side. Neglecting tube wall resistance, calculate the tube length required take $C_{water}=4180 \text{ J/kg K}$ and $C_{oil}=2090 \text{ J/kg K}$.
10. Derive an expression for average heat transfer coefficient using Film Condensation theory on a vertical surface.
11. List the assumptions made in the derivation of the Film Condensation theory.
12. Differentiate between drop-wise and film-wise condensation process.
13. Explain with a neat sketch the various regimes of the Pool-Boiling curve. Write the appropriate equations for each regime.
14. Air free Saturated steam at $T_v=90^\circ\text{C}$ ($P=70.14 \text{ Kpa}$) condenses on the outer surface of a 1.5 m long, 2.5cm OD vertical tube maintained at a uniform temperature of $T_w=70^\circ\text{C}$. Assuming film condensation, calculate the average condensation heat transfer coefficient h_m over the entire length of the tube, condensate film thickness and condensate Reynolds number at the bottom of the tube, and the total rate of condensation at the tube surface.
15. Saturated air-free steam at $T_v=50^\circ\text{C}$ ($P=12.35 \text{ Kpa}$) condenses on the outer surface of a 1m long, 2.5cm OD vertical tube maintained at a uniform temperature of $T_w=30^\circ\text{C}$. Assuming film condensation, calculate the average condensation heat transfer coefficient h_m over the entire length of the tube and the total rate of condensation at the surface of the tube.
16. A steam condenser consisting of 625 horizontal tubes (1.25cm OD and 3cm long) in a 25x25 arrays. Saturated steam at 50°C (12.35 kPa) condenses on outer surface of tubes maintained at 30°C . Find average heat transfer coefficient, heat transfer rate and condensation in condenser.
17. Air free Saturated steam at $T_v=90^\circ\text{C}$ ($P=70.14 \text{ Kpa}$) condenses on outer surface of a 6 m long, 2.5cm OD vertical tube maintained at $T_w=30^\circ\text{C}$. Calculate average condensation heat transfer coefficient over entire length of tube, rate of condensation on the tube surface.

Examination	S, S, A	B	C,D,E	F	% Passing
June-July 18	10	19	29	4	94
June-July 17	3	9	40	1	98

Prepared by	Checked by		
Dr. K. M. Akkoli	Dr. S. A. Alur	HOD	Principal



Hirasugar Institute of Technology, Nidasoshi.

Inculcating Values, Promoting Prosperity
Approved by AICTE, Recognized by Govt. of Karnataka and Affiliated to VTU Belagavi.

Accredited at 'A' Grade by NAAC
Programmes Accredited by NBA: CSE, ECE, EEE & ME.

Mech. Engg.

Course Plan

VI A & B

2019-20(EVEN)

Subject Title	DESIGN OF MACHINE ELEMENTS II		
Subject Code	17ME64	IA Marks	40
Number of Lecture Hrs / Week	03L+02T	Exam Marks	100
Total Number of Lecture Hrs	50	Exam Hours	03
CREDITS – 04			

FACULTY DETAILS:

Name: Prof.D.N.Inamdar	Designation: Assistant. Professor	Experience: 17
No. of times course taught: 06	Specialization: Machine Design	
Name: Prof. S B Awade	Designation: Assistant. Professor	Experience: 6
No. of times course taught: 04	Specialization: Machine Design	

1.0 Prerequisite Subjects:

Sl. No	Branch	Semester	Subject
01	Applied Science	I to IV	Engineering Mathematics
02	Mechanical Engineering	I/II	CAED
03	Mechanical Engineering	III	CAMD , Mechanics Of Materials , Kinematics OF Machine
04	Mechanical Engineering	V	Design of Machine Elements I

2.0 Course Objectives

CO1	To understand various elements involved in a mechanical system.
CO2	To analyze various forces acting on the elements of a mechanical system and design them using appropriate techniques, codes, and standards.
CO3	To select transmission elements like gears, belts, pulleys, bearings from the manufacturers' catalogue.
CO4	To design completely a mechanical system integrating machine elements.
CO5	To produce assembly and working drawings of various mechanical systems involving machine elements like belts, pulleys, gears, springs, bearings, clutches and brakes.

3.0 Course Outcomes

The student, after successful completion of the course, will be able to

Course Code	Course Outcome	POs
C320.1	Design and analyze behavior of stresses in curved beams and compound cylinders.	PO1,PO2,PO3,PO5,PO6,PO8,PO11,PO12
C320.2	Design belts, wire ropes and chain drives & springs for Mechanical systems	PO1,PO2,PO3,PO5,PO6,PO8,PO11,PO12
C320.3	Design different types of gears and simple gear boxes for different applications.	PO1,PO2,PO3,PO5,PO6,PO8,PO11,PO12
C320.4	Design brakes and clutches	PO1,PO2,PO3,PO5,PO6,PO8,PO11,PO12
C320.5	Select suitable lubricants and analyze performance of hydrodynamic, hydrostatic and antifriction bearings.	PO1,PO2,PO3,PO5,PO6,PO8,PO11,PO12
Total Hours of instruction		50



4.0 Course Content

Modules	Teaching Hours	Revised Bloom's Taxonomy (RBT) Level
MODULE 1		
Curved Beams: Stresses in curved beams of standard cross sections used in crane hook, punching presses & clamps, closed rings and links. Cylinders & Cylinder Heads: Review of Lame's equations; compound cylinders, stresses due to different types of fit on cylinders; cylinder heads and flats	08 Hours	L1, L2, L3, L4
MODULE 2		
Belts: Materials of construction of flat and V belts, power rating of belts, concept of slip and creep, initial tension, effect of centrifugal tension, maximum power condition. Selection of flat and V belts- length & cross section from manufacturers' catalogues. Construction and application of timing belts. Wire ropes: Construction of wire ropes, stresses in wire ropes, and selection of wire ropes. (Only theoretical treatment) Chain drive: Types of power transmission chains, modes of failure for chain, and lubrication of chains. (Only theoretical treatment) Springs: Types of springs, spring materials, stresses in helical coil springs of circular and non-circular cross sections. Tension and compression springs, concentric springs; springs under fluctuating loads. Leaf Springs: Stresses in leaf springs, equalized stresses, and nipping of leaf springs. Introduction to torsion and Belleville springs.	10 Hours	L2, L3
MODULE 3		
Gear drives: Classification of gears, materials for gears, standard systems of gear tooth, gear tooth failure modes and lubrication of gears. Spur Gears: Definitions, stresses in gear tooth: Lewis equation and form factor, design for strength, dynamic load and wear. Helical Gears: Definitions, transverse and normal module, formative number of teeth, design based on strength, dynamic load and wear. Bevel Gears: Definitions, formative number of teeth, design based on strength, dynamic load and wear.	12 Hours	L2, L3, L4
MODULE 4		
Worm Gears: Definitions, types of worm and worm gears, and materials for worm and worm wheel. Design based on strength, dynamic, wear loads and efficiency of worm gear drives. Design of Clutches: Types of clutches and their applications, single plate and multi-plate clutches. (Numerical examples only on single and multi-plate clutches) Design of Brakes: Types of Brakes, Block and Band brakes, self locking of brakes, and heat generation in brakes.	10 Hours	L2, L3
MODULE 5		
Lubrication and Bearings: Lubricants and their properties, bearing materials and properties; mechanisms of lubrication, hydrodynamic lubrication, pressure development in oil film, bearing modulus, coefficient of friction, minimum oil film thickness, heat generated, and heat dissipated. Numerical examples on hydrodynamic journal and thrust bearing design. Anti friction bearings: Types of rolling contact bearings and their applications, static and dynamic load carrying capacities, equivalent bearing load, load life relationship; selection of deep groove ball bearings from the manufacturers' catalogue; selection of bearings subjected to cyclic loads and speeds; probability of survival.	10 Hours	L2, L3, L4

5.0 Relevance to future subjects



Sl No	Semester	Subject	Topics
01	VII	Design Lab	Lubrication Experiment
02	VIII	Project work	Design and Drawings, Part Modeling

6.0 Relevance to Real World

SL.No	Real World Mapping
01	Industrial drawings and design of various components
02	Design of Automobile, Boilers, Heat exchangers and other industrial components
03	Development of a software applications

7.0 Gap Analysis and Mitigation

Sl. No	Delivery Type	Details
01	Tutorial	Topic: Spur Gear & Helical Gear

8.0 Books Used and Recommended to Students

Text Books
1) Richard G. Budynas, and J. Keith Nisbett, "Shigley's Mechanical Engineering Design", McGraw-Hill Education, 10 th Edition, 2015.
2) Juvinall R.C, and Marshek K.M, "Fundamentals of Machine Component Design", John Wiley & Sons, Third Edition, Wiley student edition, 2007.
3) V. B. Bhandari, "Design of Machine Elements", 4th Ed., Tata McGraw Hill, 2016.
Reference Books
1) Robert L. Norton "Machine Design- an integrated approach", Pearson Education, 2 nd edition.
2) Spotts M.F., Shoup T.E "Design and Machine Elements", Pearson Education, 8 th edition, 2006.
3) Orthwein W, "Machine Component Design", Jaico Publishing Co, 2003.
4) Hall, Holowenko, Laughlin (Schaum's Outline Series), "Machine design" adapted by S.K.Somani, Tata McGraw Hill Publishing Company Ltd., Special Indian Edition, 2008.
5) G. M. Maithra and L.V.Prasad, "Hand book of Mechanical Design", Tata McGraw Hill, 2 nd edition, 2004.
Additional Study material & e-Books
1) Design Data Hand Book, K.Lingaiah, McGraw Hill, 2 nd edition, 2003.
2) Design Data Hand Book, K.Mahadevan and Balaveera Reddy, CBS publication.
3) Design Data Hand Book, H.G.Patil, I.K.International Publisher, 2010
4) PSG Design Data Hand Book, PSG College of technology, Coimbatore.

9.0 Relevant Websites (Reputed Universities and Others) for Notes/Animation/Videos Recommended

Website and Internet Contents References
1. https://en.wikipedia.org/wiki/Machine_element
2. www.nptel.ac.in
3. https://cosmolearning.org
4. www.vtu.ac.in
5. http://nevonprojects.com/mini-projects-for-mechanical-engineering/

**10.0****Magazines/Journals Used and Recommended to Students**

S.No	Magazines/Journals	website
1	Journal of Machine Design	http://www.mdesign.ftn.uns.ac.rs/
2	International Journal of Solids and Structures	http://www.sciencedirect.com/science/journal/00207683
3	Journal of Advanced Mechanical Design, Systems, and Manufacturing	https://www.jstage.jst.go.jp/article/jamdsm/4/5/4_5_795/_pdf
4	International Journal of Design Engineering	http://www.inderscience.com/jhome.php?jcode=IJDE

11.0**Examination Note****Scheme of Examination:**

Two questions to be set from each module. Students have to answer five full questions, choosing one full question from each module.

Assignment:

Course work includes a **Design project**. Design project should enable the students to design a mechanical system (like single stage reduction gear box with spur gears, single stage worm reduction gear box, V-belt and pulley drive system, machine tool spindle with bearing mounting, C-clamp, screw jack, single plate clutch, etc.) A group of students (maximum number in a group should be 4) should submit assembly drawing and part drawings, completely dimensioned, indicating the necessary manufacturing tolerances, surface finish symbols and geometric tolerances wherever necessary. Design project must be completed using appropriate solid modeling software. Computer generated drawings must be submitted.

Design calculations must be hand written and should be included in the report.

Design project should be given due credit (5 marks) in internal assessment.

12.0**Course Delivery Plan**

Module No.	Lecture No.	Content of Lecture	% of Portion
1	1	Curved Beams: Stresses in curved beams of standard cross sections used in crane hook	16%
	2	Stresses in curved beams of standard cross sections used in punching presses & clamps	
	3	Stresses in closed rings and links.	
	4	Cylinders & Cylinder Heads: Review of Lame's equations; compound cylinders	
	5	Stresses due to different types of fit on cylinders	
	6	Stresses in cylinder heads and flats.	
	7	Problems.	
	8	Discussion of recent VTU question Paper problems.	
2	9	Belts: Materials of construction of flat and V belts, power rating of belts, concept of slip and creep,	20%
	10	Initial tension, effect of centrifugal tension, maximum power condition.	
	11	Selection of flat and V belts- length & cross section from manufacturers' catalogues. Construction and application of timing belts.	
	12	Wire ropes: Construction of wire ropes, stresses in wire ropes, and selection of wire ropes.(Only theoretical treatment)	
	13	Chain drive: Types of power transmission chains, modes of failure for chain, and lubrication of chains. (Only theoretical treatment)	
	14	Springs: Types of springs, stresses in helical coil springs of circular and non- circular cross-sections,	
	15	Tension and compression springs, springs under fluctuating loads, Energy stored in springs,	
	16	Leaf springs, Stresses in Leaf springs	



S J P N Trust's
Hirasugar Institute of Technology, Nidasoshi.

Inculcating Values, Promoting Prosperity
 Approved by AICTE, Recognized by Govt. of Karnataka and Affiliated to VTU Belagavi.

Accredited at 'A' Grade by NAAC
Programmes Accredited by NBA: CSE, ECE, EEE & ME.

Mech. Engg.
Course Plan
VI A & B
2019-20(EVEN)

	17	Equalized stresses and nipping of leaf springs.	
	18	Introduction to Torsion, Belleville springs.	
3	19	Gear drives: Classification of gears, materials for gears, standard systems of gear tooth.	24%
	20	Gear tooth failure modes and lubrication of gears.	
	21	Spur Gears: Definitions, stresses in gear tooth: Lewis equation and form factor.	
	22	Design of spur Gear for strength, dynamic load and wear with an illustrative example	
	23	Discussion of recent VTU question Paper problems.	
	24	Helical Gears: Definitions, transverse and normal module, formative number of teeth	
	25	Design of helical gear based on strength, dynamic load and wear with an illustrative example	
	26	Discussion of recent VTU question Paper problems.	
	27	Bevel Gears: Definitions, formative number of teeth.	
	28	Design of bevel gear based on strength, dynamic load and wear with an illustrative example	
	29	Discussion of recent VTU question Paper problems.	
	30	Discussion on Assignment of design project on mechanical systems	
4	31	Worm Gears: Definitions, types of worm and worm gears, and materials for worm and worm wheel.	20%
	32	Design based on strength, dynamic, wear loads and efficiency of worm gear drives with an illustrative example	
	33	Discussion of recent VTU question Paper problems.	
	34	Design of Clutches: Types of clutches and their applications, single plate and multi-plate clutches.	
	35	Numerical examples on single plate clutches	
	36	Numerical examples on multi-plate clutches	
	37	Design of Brakes: Types of Brakes, Block and Band brakes	
	38	Numerical examples on Block brakes	
39	Numerical examples on Band brakes		
40	self locking of brakes and Heat generation in brakes		
5	41	Lubrication and Bearings: Lubricants and their properties, bearing materials and properties	20%
	42	mechanisms of lubrication, hydrodynamic lubrication, pressure development in oil film, bearing modulus, coefficient of friction, minimum oil film thickness, heat generated, and heat dissipated.	
	43	Numerical examples on hydrodynamic journal design	
	44	Numerical examples on thrust bearing design	
	45	Anti friction bearings: Types of rolling contact bearings and their applications,	
	46	Static and dynamic load carrying capacities, equivalent bearing load, load life relationship	
	47	Selection of deep groove ball bearings from the manufacturers' catalogue	
	48	Selection of bearings subjected to cyclic loads and speeds; probability of survival.	
	49	Discussion of recent VTU question Paper problems.	
	50	Discussion on Assignment of design project on mechanical systems	

13.0 Assignments, Pop Quiz, Mini Project, Seminars

S.No.	Title	Outcome	Allied study	Week No.	Individual	Reference:
-------	-------	---------	--------------	----------	------------	------------



		expected			/ Group activity	book/website /Paper
1	Assignment 1 to 5: University Questions from Text Books mentioned in VTU Syllabus and from previous question papers	Students study the Topics and write the Answers. Get practice to solve university questions.	Modules 1,2,3,4,5 of the syllabus	After completion of respective Modules	Individual Activity. with due credit in internal assessment.	Refer all the above mentioned text books & reference books
2	Group Assignment on Design project to enable the students to design a mechanical system Like <ul style="list-style-type: none"> • single stage reduction gear box with spur gears, single stage worm • Reduction gear box, • V-belt and pulley drive system • Machine tool spindle with bearing mounting, • C-clamp, • screw jack, • single plate clutch, etc 	Student should able to <ul style="list-style-type: none"> • design different Mechanical systems involving springs, belts and pulleys, different types of gears and simple gear boxes for different applications, & C-clamp, screw jack, single plate clutch, etc • Design calculations must be hand written and should be included in the report. 	Modules 1,2,3,4,5 of the syllabus for design Calculations & Modeling CAD Software's like, Solid edge,Catia,So lidworks AutoCAD & Pro-E Etc.	After completion of respective Modules	Group Activity & Design project with due credit (5 marks) in internal assessment.	Refer all the above mentioned text books & reference books and Use any of the below mentioned Modeling CAD Software's like, Solidedge,Catia, Solidworks AutoCAD & Pro-E Etc, http://nevonprojects.com/mini-projects-for-mechanical-engineering/

14.0

QUESTION BANK

Module 1: Curved Beams:



S J P N Trust's
Hirasugar Institute of Technology, Nidasoshi.

Inculcating Values, Promoting Prosperity
 Approved by AICTE, Recognized by Govt. of Karnataka and Affiliated to VTU Belagavi.

Accredited at 'A' Grade by NAAC
 Programmes Accredited by NBA: CSE, ECE, EEE & ME.

Mech. Engg.
Course Plan
VI A & B
2019-20(EVEN)

		expected			/ Group activity	book/website /Paper
1	Assignment 1 to 5: University Questions from Text Books mentioned in VTU Syllabus and from previous question papers	Students study the Topics and write the Answers. Get practice to solve university questions.	Modules 1,2,3,4,5 of the syllabus	After completion of respective Modules	Individual Activity. with due credit in internal assessment.	Refer all the above mentioned text books & reference books
2	Group Assignment on Design project to enable the students to design a mechanical system Like <ul style="list-style-type: none"> • single stage reduction gear box with spur gears, single stage worm • Reduction gear box, • V-belt and pulley drive system • Machine tool spindle with bearing mounting, • C-clamp, • screw jack, • single plate clutch, etc 	Student should able to <ul style="list-style-type: none"> • design different Mechanical systems involving springs, belts and pulleys, different types of gears and simple gear boxes for different applications, & C-clamp, screw jack, single plate clutch, etc • Design calculations must be hand written and should be included in the report. 	Modules 1,2,3,4,5 of the syllabus for design Calculations & Modeling CAD Software's like, Solid edge, Catia, Solidworks AutoCAD & Pro-E Etc.	After completion of respective Modules	Group Activity & Design project with due credit (5 marks) in internal assessment.	Refer all the above mentioned text books & reference books and Use any of the below mentioned Modeling CAD Software's like, Solidedge, Catia, Solidworks AutoCAD & Pro-E Etc, http://nevonprojects.com/mini-projects-for-mechanical-engineering/



14.0 QUESTION BANK

Module 1: Curved Beams:

1 Determine the maximum tensile, compressive and shear stress induced in a 'C' frame of a hydraulic riveter shown in Fig. 1.1.

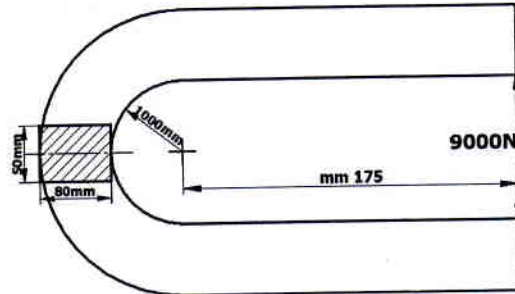

Fig:1.1

2 The frame of a punch press is shown in Fig.1.2. Find the stress in inner and outer surfaces at section A-B of the frame if $F=5000\text{N}$

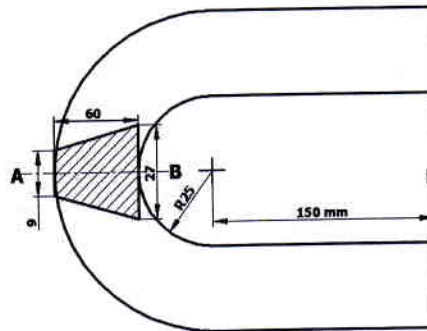

Fig:1.2

3 Fig.1.3 shows a frame of a punching machine and its various dimensions. Determine the maximum stress in the frame, if it has to resist a force of 85KN.

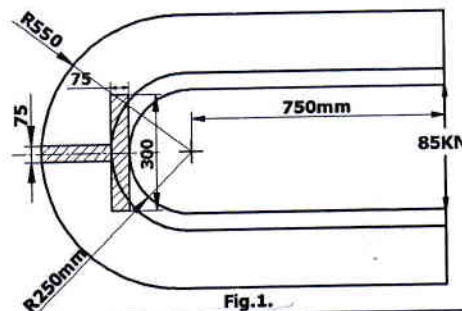

Fig.1.

4 Determine the stresses at point A and B of the split ring shown in Fig. 1.4.

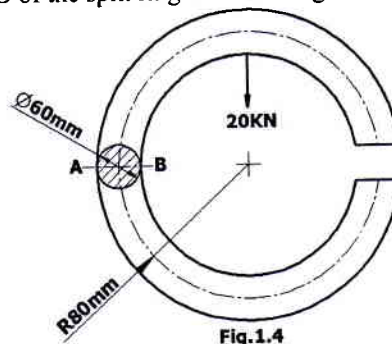
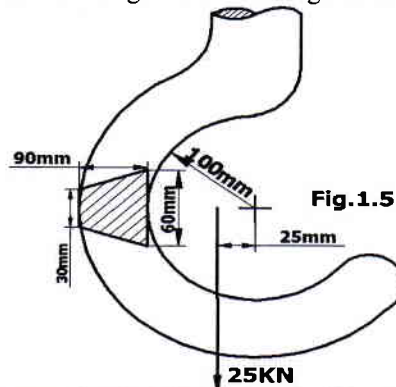

Fig.1.4

5 Compute the combined stresses at the inner and outer fibers in the critical cross section of a crane hook which is required to lift loads up to 25KN. The hook has trapezoidal cross-section with parallel sides 60mm and 30mm, the



distance between them being 90mm. The inner radius of the hook is 100mm. The load line is nearer to the inner surface of the hook by 25mm than the center of curvature at the critical section. What will be the stresses at the inner and outer fiber, if the beam is treated as straight beam for the given load? (Refer Fig.1.5).



6 The section of a crane hook is rectangular in shape whose width is 30mm and depth is 60mm. The center of curvature is the section is at a distance is 125mm from the inside section and the load line is 100mm from the same point. Find the capacity of the hook if the allowable stress in tension is 75N/mm^2 (refer Fig.1.6)

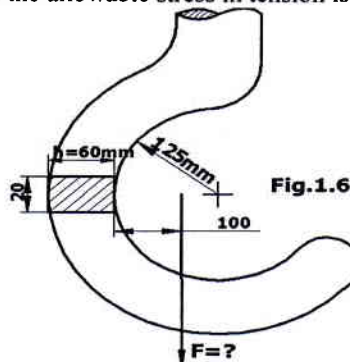

7 Determine the force F such that the maximum tensile stress in the clamp is not to exceed 140N/mm^2 . (Refer Fig.1.7)

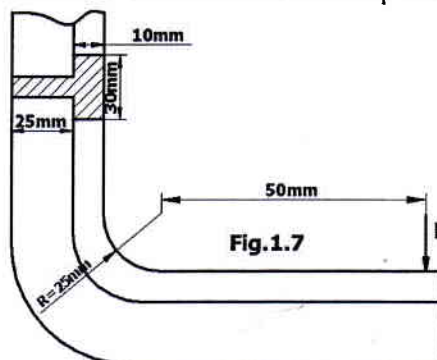

8 Determine the maximum tensile and maximum shear stresses of the component shown in Fig.1.8 and indicate the location.

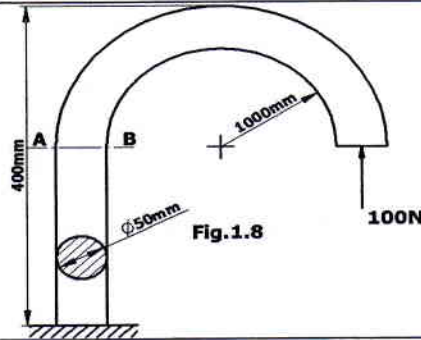

9 Determine the dimension of the curved bar shown in Fig.1.20. assume $\sigma_{yt} = 400\text{N/mm}^2$ and $\text{fos}=3.5$

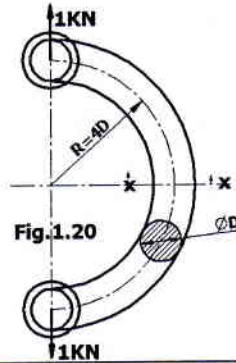

10 Find the stresses at the inner and outer fiber of the machine frame of 'I' section as shown in Fig.1.15.

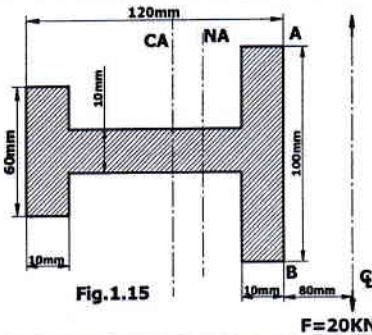

11 Determine the capacity of a frame of a punch press shown in Fig. 1.12. The material from which the frame is made has an allowable stress of stress of 80N/mm^2 along the section A-B.

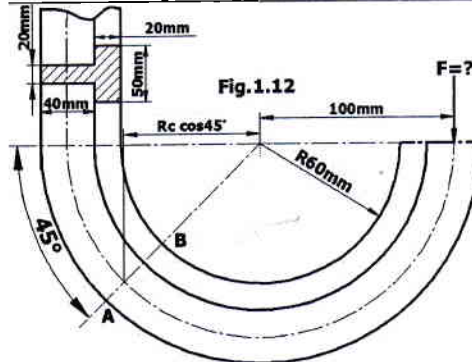

12 A chain link made of 40mm diameter rod is semi circular at each end, the mean diameter of which is 80mm. the straight sides of the link length are also equal to 80mm. if the link carries a load of 90kN, estimate the tensile and compressive stresses in the link along the section of load line. Also find the stresses at a section 90° away from the load line.

13 For the section A-B shown in Fig. 1.18 find bending moment, direct tensile force, maximum tensile stress, maximum compressive stress, maximum shear stress and their locations.

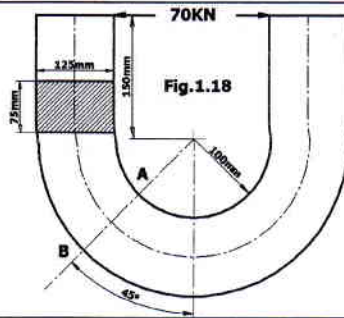

14 Determine the dimensions of 'I' section shown in Fig. 1.19 in which both extreme fiber stresses are numerically equal in pure bending. Also find the maximum stress if the load is 20kN and $b_i + b_o = 125\text{mm}$.

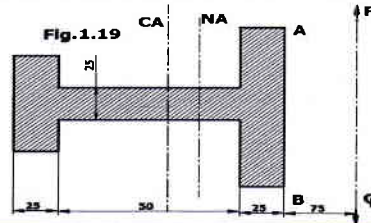

15 A curved beam with a circular center line has trapezoidal cross-section and is subjected to pure bending in its plane of symmetry. The concave side face is 100mm and from the center line of curvature. The depth is 100mm. Find the proper value of other parallel face, if the maximum extreme fiber stress in tension and compression are numerically equal. Determine the magnitude of couple if it is subjected to a maximum fiber stress of 50N/mm^2 .

16 Using usual notations prove that the moment of resistances M of a curved beam of initial radius R_1 when bent to a radius R_2 by uniform bending moment is $M = EAeR_1[1/R_1 + 1/R_2]$.

17 List out the main differences between straight and curved beam. Also sketch the stress distribution pattern in a curved beam and compare it with a straight beam.

18 Derive an expression for stress distribution due to bending moment in a curved beam.

19 Explain why curved beams have to be analyzed for stresses especially when we already have straight beam equations for determining the stresses?

20 Compute the combined stresses at the inner and outer fibers in the critical cross section of a crane hook which is required to lift loads up to 25kN. The hook has trapezoidal cross section with parallel sides 60mm and 30mm, the distance between them being 90mm. The inner radius of the hook is 100mm. The load is nearer to the inner surface of the hook by 25mm than the center of curvature at the critical section. What will be the given stresses at the inner and outer fiber, if the beam is treated as straight beam for the given load?

Module 1: Cylinders and cylinders heads:(CONTINUED)

1 The storage capacity of a seamless cylinder is 0.0151m^3 and it is subjected to an internal pressure of 15MPa. The cylinder material is alloy steel ($\sigma_t = 500\text{N/mm}^2$) and a factor of safety 2.5 is used. The length of the cylinder is twice its internal diameter. Determine the thickness of the cylinder wall.

2 A cylindrical vessel whose ends are closed by means of hemispherical covers is subjected to an internal pressure of N/mm^2 . The length of the cylindrical portion is twice that of its internal diameter. The allowable tensile stress of the material of the vessel is 82.5N/mm^2 and its storage capacity is 0.345m^3 . Neglecting the effect of welded joints and the allowance for corrosion, determine its dimensions.

3 A cast iron cylinder of internal diameter 500mm and 75mm thick is filled with a fluid of pressure 6N/mm^2 . Determine the tangential stress and radial stress distribution across its thickness.

4 A hydraulic press has a maximum capacity of 10kN. The friction due to piston packing is equivalent to 10% of its capacity. The cylinder is made of cast iron whose ultimate tensile strength is 240MPa. Diameter of the piston is 50mm and factor of safety is 4. Determine the wall thickness of the cylinder.

5 Determine the thickness of metal necessary for a cylinder of internal diameter 160mm to withstand an internal fluid pressure of 8N/mm^2 . The maximum tangential stress in the section is not to exceed 35N/mm^2 . The material may be assumed as a brittle material.

6 The inside diameter of a cylindrical tank is 200mm. The gas pressure inside the cylinder is 10MPa. The tank is made of carbon steel whose ultimate strength is 400N/mm^2 and the factor of safety is 5. Find the wall thickness of the cylinder. Poisson's ratio of the material is 0.3.

7 A seamless steel pipe of 150mm internal diameter is subjected to internal pressure of 10MPa. The pipe is made of steel whose tensile strength at the yield point is 240N/mm^2 and the factor of safety is 3. Poisson's ratio of the material is 0.27. Determine the wall thickness of the pipe.

8 A cast iron cylindrical pipe of outside diameter 300mm and inside diameter 200mm is subjected to an internal fluid pressure of 20N/mm^2 and external fluid pressure of 5N/mm^2 . Determine the tangential and radial stresses at the



	inner, middle and outer surface. Also sketch the tangential stress and radial stress distribution across its thickness.
9	A carbon steel C50 barrel with diameter 25mm and 50mm is to be shrink fitted into another barrel with diameter 50mm and 75mm. the tangential stress developed at the inner fiber of the outer barrel due to shrink fitting may be limited to 70N/mm ² . Determine, i) Contact pressure, ii) Original diameter at contact before shrink fitting and iii) Resulting stress distribution due to shrink fitting. Take $E=21 \times 10^4 \text{ N/mm}^2$.
10	Design a shrink fit joint two cylinders of diameter 150mmX200mm and 200mmX250mm. Maximum tangential stress in the components due to shrinks fitting is to be limited to 40MPa. Also determine the axial force necessary to dis-engage the joint if the length of the joint is 200mm and the maximum power that can be transmitted at a rated speed of 1000rpm. The material of the cylinder has a modulus of elasticity 210GPa and Poisson's ratio 0.3.
11	A 440mm outer diameter, 250mm inner diameter and 300mm long steel hub is to be shrink on to a 250mm diameter steel shaft. If the torque to be transmitted is 300KNm and $\mu=0.18$, determine the amount of interference required.
12	A high pressure cylinder consists of a steel tube with inner and outer diameters of 120mm and 160mm respectively. It is jacketed by an outer tube with an outer diameter of 200mm. The tubes are assembled by a shrinking process in such a way that maximum principal stress induced is 36.45 N/mm ² . The shrink fit assembly is further subjected to an internal fluid pressure of 60 N/mm ² . Determine, i) Shrinkage pressure, ii) Resultant tangential and radial stresses and plot the stress distribution.
13	A steel tube with inner and outer diameters of 50mm and 75mm respectively is jacketed by an outer steel tube with an outer diameter of 100mm. the compound tube is subjected to an internal pressure of 35MPa. The shrinkage allowance is such that the maximum tangential stress in each tube has same magnitude. Find, i) Shrinkage pressure, ii) Original dimensions of tubes. Also plot the distribution of tangential stresses.
14	A cast iron thick cylinder of internal diameter 150mm is subjected to an internal pressure of 12 N/mm ² . The allowable working stress for the cast iron may be taken as 20 N/mm ² . Determine, i) Thickness of cylinder wall, ii) Thickness of the circular flat cylinder head cast integral with the cylinder walls.
15	A cylinder is provided with a head of flat circular steel plate of 500mmdiameter and is supported around the edge. It is subjected to a uniform pressure of 5 N/mm ² . The allowable working stress for the material is 70 N/mm ² and Poisson's ratio is 0.3. Determine the i) thickness of thick cylinder wall, ii) Thickness of the circular flat cylinder head.
16	A fusion welded thin cylindrical shell of internal diameter 200mm is filled with ammonium gas, under pressure 5 N/mm ² . The ends of the cylindrical shell are closed by dished head with the inside convex. The radius of curvature of the head is 200mm. the material of the cylindrical shell and head is Fe 360 steel and factor of safety 5. Determine, i) Thickness of cylindrical shell and ii) Thickness of head.
17	A fusion welded thin cylindrical shell of internal diameter 2000mm is subjected to an internal pressure of 1 N/mm ² . The yield strength of the material of the shell is 250 N/mm ² with a factor of safety of 2.5. The ends of the cylindrical shell are closed by torispherical heads with a crown radius of 1.6m and the corrosion allowance is 3mm. Determine, i) Thickness of cylindrical shell and ii) Thickness of head.
18	A cast steel cylinder of 300mm internal diameter is to contain liquid at a pressure of 12.5 N/mm ² . It is closed at both ends by unstayed flat cover plates and is attached by bolts. Determine the thickness of the cover plates if the allowable working stress for the cover material is 75 N/mm ² .
Module 2: Design of Belts, Wire Rope and chains Drives:	
1	Show that in flat belt drives the ratio of belt tensions is given by $T_1/T_2=e^{\mu\theta}$, Where T_1 and T_2 are belt tensions, μ is the coefficient of friction and θ is the angle of lap.
2	Derive an expression for the ratio of tension in V-belt drive.
3	A belt is required to transmit 18.5 KW from a pulley of 1.2m diameter running at 250rpm to another pulley which runs at 500rpm. The distance between the centers of pulleys is 2.7m. The following data refer to an open belt drive $\mu=0.25$. Safe working stress for leather is 1.75N/mm ² . Thickness of belt =10mm. Determine the width and length of belt taking centrifugal tension into account. Also find the initial tension in the belt and absolute power that can be transmitted by this belt and the speed at which this can be transmitted.
4	A flat belt is required to transmit 10KW from a pulley of 600mm effective diameter running at 300rpm. The angle of contact is spread over 7/16 of circumference. Determine the width of belt whose thickness is 10mm. The allowable stress for the belt is 2.25N/mm ² . Coefficient of friction between the pulley and belt is 0.3.
5	Design a belt drive to transmit 25KW from a motor shaft rotating at 1500rpm to a compressor running at 500rpm.



	The motor pulley is 96mm effective diameter and the centre distance between the shafts is 1.5m.
6	A belt of 100mm wide and 10mm thick is transmitting power at 1000m/min. The nit driving tension is 2 times the slack side tension. Allowable stress in the belt material is 2MPa. Specific weight of the belt material is 10KN/m ³ . Determine the power that can be transmitted by the belt. Also determine the absolute power that can be transmitted by the belt and the velocity at which that power can be transmitted.
7	Select a V-belt drive to transmit 10KW of power from a pulley of 200mm diameter mounted on an electric motor running at 720rpm to another pulley mounted on compressor running at 200rpm. The service is heavy duty varying from 10 hours to 14 hours per day and centre distance between centers of pulley is 600mm.
8	A compressor is driven by a motor of 2.5KW running at 1200rpm to a 400rpm compressor. Select a suitable V-belt.
9	A V-belt is to transmit 20KW from a 250mm pitch diameter sheave operating at 1500rpm to a 900mm diameter flat pulley. The centre distance between input and output shafts is 1m. The groove angle is 40° and coefficient of friction is 0.2 for both pulleys and sheaves combination. The cross-section of the belt is 38mm wide at the top and 19mm wide at the bottom by 25mm deep. Each belt weighs 11KN/m ³ and allowable tension per belt is 1000N. How many belts are required?
10	Select a wire rope to lift a load of 10KN through a height of 600m from a mine. The weight of bucket is 2.5KN. The load should attain a maximum speed of 50m/min in 2 seconds.
11	Select a wire rope for a vertical mine hoisting to lift 12000KN of ore in 8 hour shift from a depth of 720m. Assume two compartments skip with the hoisting skips in balance. The maximum velocity of the rope is 750m/min with an acceleration and deceleration period of 12seconds. The rest period for load and unload is 10seconds. The hoisting skip weights approximately 50% of the load capacity.
12	Select a roller chain drive to transmit power of 10KW from a shaft rotating at 750rpm to another shaft to be run at 450rpm. The distance between the shaft centers could be taken as 35 pitches.
13	Select a chain drive to actuate a compressor from 10KW electric motor at 670rpm, the compressor rpm being 350. Minimum, centre distance should be approximately 560mm. The chain tension may be adjusted by shifting the motor on rails. Compressor is to work for 10 hours per day.
14	Select a chain drive to actuate the compressor from 15KW electric motor at 600rpm, while the compressor rpm being 120.
15	A roller chain is to transmit 66.24KW from a 17 tooth sprocket to a 34 tooth sprocket at a pinion speed of 300rpm. The loads are moderate shock. The equipment is to run 18hour per day. Specify the length and size of the chain required for a center distance of about 25 pitches.
Module 2: Springs(continued)	
1	Design helical compression spring to support an axial load of 3000N. The deflection under load is limited to 60mm. the spring index is 6. The spring is made of Chrome-Vanadium steel and factor of safety is equal to 2.
2	A helical valve spring is to be designed for an operating load of approximately 90 to 135N. The deflection of the spring for the load range is 7.5 mm. Assume a spring index of 10 and factor of safety =2. Design the spring.
3	Design a valve spring for an automobile engine, when the valve is closed, the spring produces a force of 45N and when it opens, produces a force of 55N. The spring must fit over the valve bush which has an outside diameter of 20mm and must go inside a space of 35mm. The lift of the valve is 6mm. The spring index is 12. The allowable stress may be taken as 0.33 GPa. Modulus of rigidity 80GPa.
4	Round wire cylindrical compression spring has an outside diameter of 75mm. It is made of 12.5mm diameter steel wire. The spring support an axial load of 5000N, determine i) Maximum shear stress, ii) Total deflection, if the spring has 8coils with squared- ground end and is made of SAE9260, iii) Find also the pitch of coil and iv)The natural frequency of vibration of the spring if one end is at rest.
5	The spring loaded safety valve for a boiler is required to blow off at a pressure of 1.3MPa. The diameter of the valve is 65mm and maximum lift of the valve is 17.5mm. Design a suitable compression spring for the valve, assuming spring index to be 6 and providing initial compression of 30mm. Take $\tau=0.45\text{GPa}$ and $G=84\text{GPa}$.
6	The valve spring of a gasoline engine is 40mm long when the valve is open and 48mm long when the valve is closed. The spring loads are 250N when the valve is closed and 400N when the valve is open. The inside diameter of the spring is not to be less than 25mm and factor of safety is 2. Design the spring.
7	A spring controlled lever is shown in Fig. 3.5a. The spring is to be inserted with an initial compression to produce a force equal to 125N between the right end of lever and the stop. When the maximum force at A reaches a valve of 200N the end of the lever moves downward by 25mm. Assume the spring index as 8 find i) spring rate, ii) size of wire, iii) Outside diameter of spring , iv) Number of active coils, v) Free length and vi) Pitch.
8	A closed helical spring is to have a stiffness of 1N/mm, maximum load of 40N and maximum shear stress of 130 N/mm ² . The solid length is 45mm. find the diameter of wire and number of coils required. Take $G=80\text{GPa}$.
9	Design a spring used in a recoil system so as to absorb 120Nm of energy with a maximum force of 3000N. Assume spring index 8 and factor of safety is 2.



10	A railway wagon weighing 50KN and moving with a speed of 8 Km/hr has to be stopped by four buffer springs in which the maximum compression allowed is 220mm. find the number of turns or coils in each spring of mean diameter 150mm. The diameter of spring wire is 25mm. Take $G=84\text{GPa}$. Also find the shear stress.
11	A loaded narrow gauge car weighs 18KN and moving at a velocity of 80m/min is brought to rest by a buffer consists of two helical springs. In bringing the car to rest the spring undergoes a compression of 200mm. The allowable shear stress is 0.3 GPa and the spring index is 8. Design a suitable spring. Take $G=84\text{GPa}$.
12	A load of 2000N is dropped axially on a closed helical spring from a height of 250mm. The spring has 20 effective turns, and it is made of 25mm diameter wire. Find the maximum shear stress produced in the spring and the amount of compression produced. Take $c=8$ and $G=84\text{GPa}$.
13	Design a spring for an elevator shaft at the bottom of which 8 identical springs are set in parallel to absorb the shock of the elevator in case of failure. The weight of elevator is 60KN and the counter weight of elevator is 20KN. The elevator has a free fall of 1.5m from rest. The spring is made of 25mm diameter rod. Determine the maximum stress in each spring, if the spring index is 6. Each spring has 15 active turns. Take $G=84\text{GPa}$.
14	A single plate friction clutch transmits 20KW at 1000rpm. There is 2 pair of friction surfaces having a mean radius of 150mm. The axial pressure is provided by six springs. If the springs are compressed by 5mm during declutching, design the spring. Take $c=6$, $\tau=0.42\text{GPa}$, $G=80\text{GPa}$ and $\mu=0.3$.
15	Design the spring for the Hartnell type spring loaded governor for the following particulars. Mass of each ball=2.97kg, length of vertical or ball arm is 150mm, length of sleeve or horizontal arm is 112.5mm. The governor is begin to lift at a speed of 240rpm and the maximum speed is 7.5% higher than that. The maximum radius of rotation is 150mm and minimum radius of rotation is 100mm. The allowable stress on the spring material is 0.42HPa and modulus of rigidity is 84GPa. Take $c=8$.
16	Spring loaded governor with dimensions shown in Fig. 3.7a needs a spring force of 190N to permit proper speed of balls of 125mm radius. Assuming limiting position to be shown that in Fig.3.7b with balls at 175mm radius corresponding the spring force is 650N. Take $G=84\text{GPa}$, $\tau=0.35\text{GPa}$ and $c=8$. Determine i) Rate of spring ii) Wire diameter and coil diameter and iii) number of coils.
17	Design a concentric spring for an air craft engine valve to exert a maximum force of 5000N under a deflection of 40mm. Both the springs have same free length, solid length and are subjected to equal maximum shear stress of 0.85GPa spring index for both springs is 6. Assume $G=80\text{GPa}$ and diametral clearance to be equal to difference between wire diameters.
18	A rectangular section helical spring is mounted to a buffer to sustain a maximum load of 30KN. The deflection under load is limited to 100mm. The spring is made of chrome-vanadium steel with a reliability of 1.5. The longer side of the rectangle is 2 times the shorter side and the spring is wound with longer side parallel to the axis. The spring index is 10. Design the spring and draw a conventional sketch.
19	A railway car weighing 18KN and moving at a speed of 72m/min is brought to rest by a buffer consisting of 2 helical compression spring of square cross-section. In bringing the car to rest the spring under goes a deflection of 0.25m. The allowable shear stress for the steel wire is 0.3 GPa. Spring index=6. Design the spring and draw a conventional sketch. Take $G=84\text{GPa}$.
20	Determine the width and thickness of a flat spring carrying a central load of 5000N. The deflection is limited to 100mm. The spring is supported at both ends at a distance of 800mm. The allowable stress is 30N/mm ² and modulus of elasticity 221GPa. The spring is of constant thickness and varying width.
21	Determine the width and thickness of 6leaves cantilever spring 300mm long to carry a load of 1550N with a deflection of 30mm. The maximum stress in the spring should not exceed 0.330GPa. Take $E=204\text{GPa}$.
22	A locomotive spring has an overall length of 1100mm and sustains a load of 75KN at its centre. The spring has 3 full length leaves and 15 graduated leaves with a central band of 100mm. all the leaves are to be stressed at 0.4GPa when fully loaded. The ratio of total spring depth to width is 2. Determine, i) Width and thickness of leaves. ii) Initial space that must be provided between full length and graduated leaves before the band is applied and iii) What load is exerted on the band after the spring is assembled?
23	A Truck spring has 12 numbers of leaves 2 of which are full length leaves. The spring supports are 1.05m apart and the central band is 85mm wide. The central load is to be 5400N with a permissible stress of 0.28GPa. The ratio of total depth to width of spring is 3 and modulus of elasticity =210GPa. Determine i) Thickness and width of steel spring ii) maximum deflection.
25	A multi-leaf spring with camber is fitted to the chassis of an automobile over a span of 1.2m to absorb shocks due to a maximum load of 20KN. The spring material can sustain a maximum stress of 0.4GPa. All the leaves of the spring were to receive the same stress. The spring is required at least 2 full length leaves out of 8leaves. The leaves are assembled with bolts over a span of 150mm width at the middle. Design the spring for a maximum deflection of f50mm.
26	A truck spring has 10leaves of graduated length. The spring supports 1060mm apart and central band is 80mm. The central load is to be 5400N with a permissible stress as 0.28GPa. The spring should have a ratio of total depth to



	width is about 2.5. Determine the width and thickness of spring plate and deflection when loaded. To what radius should the leaves be bent initially for the spring to be flat under the given load? Take=210Gpa.
27	A helical torsion spring of mean diameter 50mm is made of a round wire of 5mm diameter. If a torque of 5Nm is applied on this spring, find the bending stress, maximum stress and deflection of the spring in degrees. Modulus of elasticity=200Gpa and number of effective turns 10.
28	Design a helical spring for spring loaded safety valve for the following data: operating pressure=1MPa; Maximum pressure when the valve blows off=1.075MPa. Maximum lift of valve when pressure is 1.075MPa=6mm. diameter of valve seat=100mm. Maximum allowable shear stress=0.4GPa. Rigidity modulus=86GPa. Spring index=5.5. Assume this to be a Rams bottom safety valve.
29	Derive the equation for energy stored in a helical spring.
30	With usual notations, derive the equations for deflection and bending stresses induced in full length leaves and graduated leaves of a laminated spring. What are the requirements of spring materials? What are the important spring materials?
31	Derive an expression for the shear stress induced in a helical compression spring, with usual notations.
32	Explain equalizing the stresses in leaf spring.
33	Define spring index, mean coil diameter and helix angle.
34	When do you recommend non-circular wire spring? Why this cross-section of the wire is not generally used?
35	What do you understand by surge in helical springs? How it can be eliminated.
Module 3: Spur & Helical Gears:	
1	Derive an expression for beam strength of spur gear tooth standard notations.
2	Explain what is meant by Lewis form factor.
3	What is interference in gears? Explain briefly.
4	With sketch explain formative or virtual number of teeth applicable to helical gear: also derive an expression for virtual number of teeth in terms of helix angle and the actual number of teeth.
5	State the assumptions made in Lewis equation.
6	A pair of mating spur gears has 20° full depth of module 5mm. The pitch diameter of smaller gear is 100mm. If transmission ratio is 4:1. Calculate i) Number of teeth for each gear ii) Addendum iii) Dedendum iv) Whole depth v) clearance vi) outside diameter vii) Tooth thickness viii) working depth ix) circular pitch x) center distance xi) base circle diameters xii) Dedendum or root circle diameters.
7	A spur gear pinion 100mm diameter has a torque of 200Nm applied to it. The spur gear mesh with it is 250mm in diameter. The pressure angle is 20°. Determine i) Tangential force F_t ii) radial or separating force F_r ii) Torque on the gear. Also show the forces acting on the wheels separately.
8	A forged steel pinion (SAE1040) rotating at 400rpm drives a high grade cast iron gear. The transmission ratio is 4:1. The pinion has 15 standards 20° full depth involute teeth of 4mm module. The face width of both gears is 40mm. How much power can be transmitted from the stand point of strength?
9	Two spur gears are to be used for a rock crusher drive and are to be minimum size. The gears are to be designed for the following requirements: Power to be transmitted is 18KW, speed of pinion 1200rev/min: Velocity ratio 3.5 to 1, tooth profile 20° stub involute. Determine module and face width for strength requirements only.
10	A pair of carefully cut spur gears with 20° full depth involute profile is used to transmit 12KW at 1200 revolutions per minute of pinion. The gear has to rotate at 300revlutions per minute. The material used for both pinion and gear is medium carbon steel whose allowable stress may be taken as 230MPa. Determine the module and face width of the spur pinion and gear. Suggest suitable hardness. Take 24 teeth on pinion. Modulus of elasticity may be taken as 210GPa.
11	Design a pair of spur gears to transmit 20KW from a shaft rotating at 1000rpm to a parallel shaft which is to rotate at 310rpm. Assume number of teeth on pinion 31 and 20° full depth tooth for. The material for pinion is C45 steel untreated and for gear cast steel 0.20%C untreated.
12	Design a bronze spur gear 81.4MN/m ² and mild steel pinion 101MN/mm ² to transmit 5KW at 1800rpm. The velocity ratio is 3.5:1. Pressure angle 14 1/2°. Not less than teeth are to be used on either gear. Determine the module and face width. Also suggest suitable surface hardness for the weaker member based on dynamic and wear considerations.
13	In an automobile gear box, the second speed gear shaft is to be driven from main shaft with velocity ration 1.5:1. Main shaft transmits 12KW at 3000rpm. The shaft center distance=80mm pinion material is cast steel heat treated and gear material is cast steel untreated. Profile of the gear is 20° stub involute. Determine i) Module ii) Face width iii) Number of teeth on pinion and gear.
14	A pair of carefully cut (class-II) spur gear transmits 20KW at 230rpm of the gear. Reduction ratio is 5:1. The pinion is made of cast steel heat treated with allowable stress 197MN/m ² . Gear is made of cast iron with allowable



Hirasugar Institute of Technology, Nidasoshi.

Approved by AICTE, Recognized by Govt. of Karnataka and Affiliated to VTU Belagavi.

Accredited at 'A' Grade by NAAC
Programmes Accredited by NBA: CSE, ECE, EEE & ME.

S J P N Trust's

Mech. Engg.

Course Plan

VI A & B

2019-20(EVEN)

	stress 56MN/m ² . Determine module, face width and number of teeth on pinion and gear. Also suggests suitable surface hardness for the gear pair. Pitch line velocity of pinion is not to exceed 7.5m/sec.
15	Design a pair of spur gears to transmit a power of 18KW from a shaft sunning at 1000rpm to a parallel shaft to be run at 250rpm maintaining a distance of 160mm between the shaft centers. Suggest suitable surface hardness for the gear pair.
16	Design a spur gear drive to transmit 12KW from 1500rpm motor to a compressor run at 50rpm.
17	A pair of mating helical gears have 20° pressure angle in the normal plane. The normal module is 5mm and the module in the diametral plane is 5.7735mm. The pitch diameter of the smaller gear is 115.47mm. If the transmission ratio is 4:1 calculate i) Helix angle ii) normal pitch iii) Transverse pitch iv) Number of teeth for each gear v) Addendum vi) Dedendum vii) Whole depth viii) Clearance ix) Tooth thickness x) Working depth xi) Outside diameters xii) Center distance xiii) Root or dedendum circle diameters xiv) Base circle diameters.
18	A pair of parallel helical gears is shown in Fig 4.14. A 5KW power at 720rpm is supplied to pinion through its shaft. The normal module is 5mm and the normal pressure angle is 20°. The pinion has right hand helix, while the gear has left hand helix. The helix angle is 30°. The arrow indicates the direction of rotation when seen from the right hand side. Determine the components of the tooth force and draw a free body diagram showing the forces acting on the pinion and the gear.
19	Design a pair of helical gears to transmit power of 15KW at 3200rpm with speed reduction 4:1 pinion is made of cast steel 0.4% C untreated. Gear made of high grade CI. Helix angle is limited to 26° and not less than 20 teeth are to be used on either gear. Suggest suitable surface hardness for the gear pair.
20	A pair of carefully cut (class-II) helical gears for a turbine has a transmission ratio of 10:1 the teeth are 20° stub involute in the normal plane. Pinion has 25 teeth and rotates at 5000rpm. Material for pinion and gear is 0.4% carbon steel untreated. Determine the module in normal plane, diametral plane and face width of the gears. Suggest suitable hardness. Modulus of elasticity may be taken as 210GPa. Helix angle = 30°. Power transmitted = 90KW.
21	Design a pair of helical gears to transmit a power of 20KW from a shaft running at 1500rpm to a parallel shaft to be run at 450rpm. Suggest suitable surface hardness for the gear pair.
22	A pair of steel helical gears is to transmit 15KW at 5000rev/min of the pinion. Both the gears are made of the same material, hardened steel with allowable bending stress of 120MPa. The gears have to operate at a centre distance of 200mm. the speed reduction ratio is 4:1. The teeth are 20° full depth involute profile on the normal plane. Helix angle is 45°. The gears are manufactured to class III accuracy (precision class). Face width can be taken as 16 times the normal module, if the wear strength has to be more than the dynamic load. Determine the following : i) Normal plane ii) Transverse module iii) Pressure angle in the transverse plane iv) Number of teeth on pinion and gear v) Face width vi) Required surface endurance limit. (note: Lewis bending strength is based on normal module)
Module 4 : Worm Gears	
1	Explain briefly the formative number of teeth of bevel gears.
2	Explain "self locking effect" in case of worm gear drive.
3	Explain spiral bevel gear and hypoid gears?
4	Sketch and describe a meshing worm gear and worm wheel. What are their advantages?
5	A pair of bevel gears transmitting 7.5KW at 300rpm of pinion. The pressure angle is 20°. The pitch diameters of pinion and gear at their large ends are 150mm and 200mm respectively. The face width of the gears is 40mm. determine the components of the resultant gear tooth force and draw a free body diagram of forces acting on the pinion and the gear.
6	Design a pair of bevel gears to connect two shafts at 60°. The gears are alloy steel of case hardened and precision cut with form cutters. The gear ratio is 5:1. The power transmitted is 30KW at 900rpm of the pinion. The teeth are 20° full depth. The pinion has 24 teeth. Suggest suitable surface hardness for the gear pair.
7	Design a pair of bevel gears to transmit a power of 25KW from a shaft rotating at 1200rpm to a perpendicular shaft to be rotated at 400rpm.
8	A pair of bevel gears to transmitting 12KW at 300rpm of the gear and 1470rpm of the pinion. The angle between the shaft axes is 90°. The pinion has 20teeth and the material for gears is cast steel ($\sigma_o=183.33N/mm^2$, BHN320). Take service factor as 1.25 and check the gears for wear and dynamic load. Suggest suitable surface hardness for the gear pair.
9	A pair of straight bevel gears transmits 15KW at 1250rpm of 120mm diameter pinion. The speed reduction is 3.5. Use 14 1/2° full depth teeth system. The pinion is made of alloy steel of case hardened and (SAE2320) gear is cast



	steel 0.20%C heat treated. Determine module, face width and number of teeth on pinion and gear. Suggest suitable hardness if the wear strength has to be more than the dynamic load.
10	A pair of bevel gear wheels with 20° pressure angle consists of 20 teeth pinion meshing with 30 teeth gear. The module is 4mm while the face width is 20mm. The surface hardness of both pinion and gear is 400 BHN. The pinion rotates at 500rpm and receives power from an electric motor. The starting torque of the motor is 150% of the rated torque. Determine the safe power that can be transmitted considering the dynamic load, wear strength and endurance strength. The allowable bending stress may be taken as 240MPa.
11	Complete the design and determine the input capacity of a worm gear speed reducer unit which consists of a hardened steel worm and a phosphor bronze gear having 20° stub involute teeth. The centre distance is to be 200mm and transmission ratio is 10 and the worm speed is 2000rpm.
12	Design a worm gear drive to transmit a power of 2KW at 1000rpm. The speed ratio is 20 and the centre distance is 200mm.
13	Design a worm gear drive to transmit a power of 40KW at 500rpm of worm. The speed is 25. Material for the gear is phosphor bronze and that of worm is hardened steel. Determine the efficiency of the drive also.
14	Two teeth right hand worm transmits 2KW at 1500rpm to a 36 teeth wheel. The module of the wheel is 5mm and the pitch diameter of the worm is 60mm. The normal pressure angle is 14.2°. The coefficient of friction is found to be 0.06. i) Find the centre distance, the lead and lead angle, ii) determine the forces and iii) determine the efficiency of the drive.
15	Design a pair of right-angled bevel gears to transmit a power of 15KW from a shaft running at a speed of 750rpm to a perpendicular shaft to be run at 250rpm. Suggest suitable surface hardness for the gear pair.
16	Design a pair of bevel gears to transmit a power of 25KW from a shaft rotating at 1200rpm to a perpendicular shaft to be rotated at 400rpm.
17	Determine the cone pitch angles, pitch diameters for the following bevel gear pairs: i) For shaft angle 77° (Acute angle bevel gearing), ii) For shaft angle 147° (Obtuse angle bevel gearing). The module is 5mm and the number of teeth on the pinion and the gear are 14 and 42 respectively. Draw the sketches of gearing.
Module 4: Clutches and Brakes (Continued)	
1	Explain briefly the uniform pressure theory and uniform wear theory as applicable to friction clutches and brakes.
2	Name the different type of clutches. Describe with the help of a neat sketch the working principles of any one friction clutch.
3	Classify the brakes and name different types of mechanical brakes.
4	Derive a relation to compute the torque developed on block brake.
5	A car engine develops maximum power of 15KW at 1000rpm. The clutch used is single plate type of both sides effective having external diameter 1.25 times internal diameter $\mu=0.3$. Mean axial pressure is not to exceed 0.085N/mm ² . Determine the dimensions of the friction surface and the force necessary to engage the plates. Assume uniform pressure condition.
6	Design a single plate clutch consists of two pairs of contacting surfaces for a torque capacity of 200Nm. Due to space limitation the outside diameter of the clutch is to be 250mm.
5	Determine the power transmitted by a single pair plate clutch assuming uniform pressure distribution. The friction surfaces have an outside diameter of 350mm and a diameter of 280mm. The coefficient of friction is 0.25 and the maximum allowable pressure is 0.85MPa.
6	Design a single plate clutch used in automobile transmission for the following specifications: power to be transmitted=20KW, speed 1500rpm to 2500rpm (max). Friction surface molded asbestos on steel.
7	In a multiple disc clutch the radial width of the friction material is to be 0.2 of maximum radius. The coefficient of friction is 0.25. The clutch is to transmit 60KW at 3000rpm. Its maximum diameter is 250mm and the axial force is limited to 600N. Determine i) Number of driving and driven discs, ii) Mean unit pressure on each contact surface. Assume uniform wear.
8	A 25KW at 3000rpm is to be transmitted by a multi-plate friction clutch. The plates have friction surfaces of steel and phosphor bronze alternatively and run in oil. Design the clutch for 25% over load.
9	A multiple plate clutch has steel on bronze is to transmit 8KW at 1440rev/min. The inner diameter of the contact is 80mm and the outer diameter of contact is 140mm. The clutch operates in oil with expected coefficient of friction of 0.1; the average allowable pressure is 0.35MPa. Assume uniform wear theory and determine the following. I) Number of steel and bronze plates ii) Axial force required iii) Actual maximum pressure.



10	Design the main dimensions of a cone clutches to transmit 40KW at 1000rpm. Assume suitable material for friction lining.
11	A cone clutch has a semi-cone angle of 12° to transmit 10KW at 750rpm. The width of the face is one fourth of the mean diameter of friction lining. If the normal intensity of pressure between the contacting surface is not to exceed 0.85 bar, assuming uniform wear theory and taking $\mu=0.2$. Calculate dimensions of clutch. Also find the axial force while running that is, at the beginning of engagement.
12	A friction cone clutch has to transmit a torque of 200Nm at 1440rev/min. The larger diameter of the cone is 350mm; the cone pitch angle is 6.25° . The face width is 65mm. The coefficient of friction is 0.2. Determine, i) The axial force required to transmit the torque, ii) The average normal pressure on the contact surfaces when the maximum torque is transmitted.
13	An engine developing 30KW at 1250rpm is fitted with a cone clutch. The cone has a face angle of 12.5° . The mean diameter is 400mm; $\mu=0.3$ and the normal pressure is not to exceed 0.08N/mm^2 . Design the clutch.
14	Design a cone clutch to transmit a power of 40KW at a rated speed of 750rpm. Also determine i) Axial force necessary to transmit torque. ii) Axial force necessary to engage the cone clutch.
15	The block brake shown in Fig 1.22 is to balance a torque of 500Nm on a drum shaft at 1000rpm. Assuming the coefficient of friction between the brake shoe and drum is to be 0.25. determine i) Tangential force on the shoe ii) normal force on the shoe iii) Force F applied to the brake for clockwise and counter clockwise rotation. iv) The dimension 'c' required to make the brake self locking assuming the other dimensions remains the same. v) Heat generated.
16	A single block brake with a torque capacity of 15Nm is shown in Fig.1.25. The coefficient of friction is 0.3 and the maximum pressure on the brake lining is 1N/mm^2 . the width of block is equal to its length calculate, i) Actuating force, ii) Dimensions of the block iii) Resultant hinge-pin reaction and iv) Rate of heat generated, if the brake drum rotates at 50rpm.
17	Fig.1.26 a shows a single block brake. The brake drum diameter is 400mm and rotates at a speed of 15rpm. The friction material permits a maximum pressure of 0.5MPa and $\mu=0.25$. Face width of the block is 50mm. If the brake is applied for 10sec at full capacity bring the shaft to stop determine, i) Effort ii) Maximum torque iii) Heat generated.
18	A single band brake shown in Fig.Q.6 (B) is to be designed to stop the rotation of a shaft transmitting a power of 45 KW at a rated speed of 500 rpm. Selecting suitable materials determine, i) Dimensions of rectangular cross section of band. ii) Dimensions of rectangular cross section brake lever. (Assume $h_1 = 2b_1$). iii) Diameter of fulcrum pin. Assume $I_p = 1.5 d_p$, bearing stress $\sigma_b = 10\text{MPa}$.

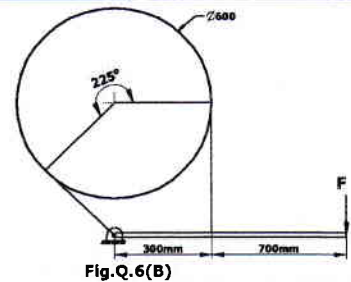

Module 5: Lubrication and Bearings:

1	What is Somerfield Number? What is its application in designing hydrodynamic journal bearing? Explain at least four dimensionless parameters, which depend upon the Somerfield Number as plotted by Raimondi and Boyd.
2	Derive Petroff's equation for coefficient of friction for Hydrodynamic bearing.
3	List the difference forms lubrication and bearing materials.
4	Explain the significance of the bearing characteristics number in the design of sliding contact bearing.
5	Explain the mechanisms of Hydrodynamic lubrication in journal bearing.
6	What are the limitations in Petroff's law?
7	What do you understand by, i) minimum oil film thickness and ii) coefficient friction in bearing.
8	Write a short note on; i) bearing modulus ii) bearing characteristics number.
9	Explain the following, i) Hydrostatic lubrication ii) Boundary lubrication iii) Thick film lubrication iv) journal bearing v) thrust bearing.
10	A 75mm long journal bearing of diameter 75mm supports a load of 10KN. The speed of the journal is 1200rpm. The absolute viscosity of the oil is 10×10^{-3} Pas and diametral clearance ratio is 0.001. Determine the coefficient of friction by using i) Petroff's equation ii) McKee's equation and iii) Raimondi and Boyd curve.
11	Determine the power loss for a Petroff's bearing 100mm in diameter and 150mm long. The radial clearance is 0.05mm. Speed of the journal is 1000rpm. The lubrication oil is SAE 10 and bearing operating temperature is 60°C.
12	The viscosity of oil is 110sayboks second at 50°C and the specific gravity is 0.8894 at 15.5°C. Determine the absolute viscosity at the bearing operating temperature of 80°C.
13	A 75mm long full journal bearing of diameter 75mm supports a radial load of 12KN at the shaft speed of 1800rev/min. Assume ratio of diameter to the diametral clearance as 1000. The viscosity of oil is 0.01 Pas at the operating temperature. Determine the following i) Sommerfeld Number ii) The coefficient friction based on Mckee's equation and iv) Amount of heat generated.
14	A lightly loaded journal bearing has a load of 1KN. The oil used is SAE60 and mean effective temperature of operation is 40°C. The journal has a diameter of 50mm and the bearing has a diameter of 50.5mm. The speed of journal is 15000rpm. The L/D ratio is limited to 1.2. Determine the coefficient of friction and power loss in friction.
15	SAE20 oil is used to lubricate a hydrodynamic journal bearing of diameter 75mm and length 75mm, oil enters 40°C. The journal rotates at 1200rpm. The diametral clearance is 75µm (0.075mm). Assume operating temperature of the oil as 53°C and determine i) Magnitude and location of the minimum film thickness ii) Power loss iii) Oil flow through the bearing and iv) Side leakage.
16	The oiliness curve for a 75mmx150mm long bearing happens to be a straight line passing through points $\eta_n/P=191 \times 10^{-9}$ and $\mu=0.002$ and another point $\eta_n/P=956 \times 10^{-9}$ and $\mu=0.0065$. The load supported by the bearing is 6 KN and the speed of the journal 1200rpm. Calculate the friction loss in KW at the bearing, if the oil film has a temperature of 80°C and the viscosity of the lubricant is 8.7cP at the operating temperature. Assume $\psi=0.001$.
17	A turbine shaft 60mm in diameter rotates at a speed of 10000rpm. The load on each bearing is estimated at 2KN and the length of bearing is 80mm. Taking radial clearance as 0.05mm and ASE-20 oil for lubrication determine the coefficient of friction, power loss, minimum film thickness and the oil flow rate. The temperature of the bearing is not to exceed 50°C.



S J P N Trust's

Hirasugar Institute of Technology, Nidasoshi.

Inculcating Values, Promoting Prosperity

Approved by AICTE, Recognized by Govt. of Karnataka and Affiliated to VTU Belagavi.

Accredited at 'A' Grade by NAAC

Programmes Accredited by NBA: CSE, ECE, EEE & ME.

Mech. Engg.

Course Plan





VI A & B

2019-20(EVEN)

16.0

University Result

Examination	S ⁺	S	A	B	C	D	E	F	% passing
2017-18	0	0	1	2	5	16	12	17	67.12
2018-19	0	0	1	5	14	9	16	17	72.58

Prepared by	Checked by		
		 13.2.2020	
Prof. S B Awade	Prof. D.N. Inamdar	HOD	Principal



S J P N Trust's

Hirasugar Institute of Technology, Nidasoshi*Inculcating Values, Promoting Prosperity*

Approved by AICTE, Recognized by Govt. of Karnataka and Affiliated to VTU Belagavi.

Accredited at 'A' Grade by NAAC**Programmes Accredited by NBA: CSE, ECE, EEE & ME.****MECH.ENGG****Course Plan****VI (A&B)****2019-20 (Even)**

Subject Title	AUTOMOBILE ENGINEERING		
Subject Code	17ME655	IA Marks	40
Number of Lecture Hrs / Week	03	Exam Marks	60
Total Number of Lecture Hrs	40	Exam Hours	03
CREDITS -3			

FACULTY DETAILS:

Name: Prof. A M Biradar	Designation: Asst. Professor	Experience: 11
No. of times course taught: 07	Specialization: Machine Design	
Name: Prof.M.R.Ingalagi	Designation: Asst.Professor	Experience: 6.5
No. of times course taught: 01	Specialization: Thermal Power Engineering	

1.0 Prerequisite Subjects:

Sl. No	Branch	Semester	Subject
01	Mechanical Engineering	III	BTD
02	Mechanical Engineering	IV	ATD
03	Mechanical Engineering	V/VI	Energy Engineering

2.0 Course Objectives

To impart the knowledge on:

1. Working of I C engines.
2. Valve timing diagram.
3. Working of clutches.
4. Various ignitions systems.
5. Super chargers and turbo chargers.
6. Lubrication systems
7. Emission control.

3.0 Course Outcomes

The student, after successful completion of the course, will be able to

	Course Outcome	Cognitive Level	POs
C323.1	To identify the different parts of an automobile and it's working	L1,L2	PO1,PO2 PO7,PO12
C323.2	To understand the working of transmission and braking systems	L2	PO1,PO2 PO7,PO12
C323.3	To comprehend the working of steering and suspension systems	L2	PO1,PO2 PO7,PO12
C323.4	To learn various types of fuels and injection systems	L2	PO1,PO2 PO7,PO12
C323.5	To know the cause of automobile emissions, its effects on environment and methods to reduce the emissions.	L2	PO1, PO7,PO12
Total Hours of instruction			40

**4.0****Course Content****MODULE 1**

ENGINE COMPONENTS AND IT'S PRINCIPLE PARTS: Spark Ignition (SI) & Compression Ignition (CI) engines, cylinder – arrangements and their relatives merits, Liners, Piston, connecting rod, crankshaft, valves, valve actuating mechanisms, valve and port timing diagrams, Types of combustion chambers for S.I. Engine and C.I. Engines, methods of a Swirl generation, choice of materials for different engine components, engine positioning. Concept of HCCI engines, hybrid engines, twin spark engine, electric car.

COOLING AND LUBRICATION: cooling requirements, types of cooling- thermo siphon system, forced circulation water cooling system, water pump, Radiator, thermostat valves. Significance of lubrication, splash and forced feed system.

8 Hours

MODULE 2

TRANSMISSION SYSTEMS: Clutch-types and construction, gear boxes- manual and automatic, gear shift mechanisms, Over drive, transfer box, fluid flywheel, torque converter, propeller shaft, slip joints, universal joints, Differential and rear axle, Hotchkiss Drive and Torque Tube Drive.

BRAKES: Types of brakes, mechanical compressed air, vacuum and hydraulic braking systems, construction and working of master and wheel cylinder, brake shoe arrangements, Disk brakes, drum brakes, Antilock – Braking systems, purpose and operation of antilock-braking system, ABS Hydraulic Unit, Rear-wheel antilock & Numerical

08 Hours

MODULE 3

STEERING AND SUSPENSION SYSTEMS: Steering geometry and types of steering gear box-Power Steering, Types of Front Axle, Suspension, Torsion bar suspension systems, leaf spring, coil spring, independent suspension for front wheel and rear wheel, Air suspension system.

IGNITION SYSTEM: Battery Ignition system, Magneto Ignition system, electronic Ignition system.

08 Hours

MODULE 4

SUPERCHARGERS AND TURBOCHARGERS: Naturally aspirated engines, Forced Induction, Types of superchargers, Turbocharger construction and operation, Intercooler, Turbocharger lag.

FUELS, FUEL SUPPLY SYSTEMS FOR SI AND CI ENGINES: Conventional fuels, alternative fuels, normal and abnormal combustion, cetane and octane numbers, Fuel mixture requirements for SI engines, types of carburetors, C.D.& C.C. carburetors, multi point and single point fuel injection systems, fuel transfer pumps, Fuel filters, fuel injection pumps and injectors. Electronic Injection system, Common Rail Direct Injection System.

08 Hours

MODULE 5

AUTOMOTIVE EMISSION CONTROL SYSTEMS: Different air pollutants, formation of photochemical smog and causes. Automotive emission controls, Controlling crankcase emissions, Controlling evaporative emissions, Cleaning the exhaust gas, Controlling the air-fuel mixture, Controlling the combustion process, Exhaust gas recirculation, Treating the exhaust gas, Air-injection system, Air-aspirator system, Catalytic converter.

EMISSION STANDARDS: Euro I, II, III and IV norms, Bharat Stage II, III, IV norms. Motor Vehicle Act

08 Hours

**5.0 Relevance to future subjects**

Sl No	Semester	Subject	Topics
01	VIII	Project work	Fuel, engine systems, driving systems

6.0 Relevance to Real World

SL.No	Real World Mapping
01	Industrial applications and design of various components
02	Design of driving systems
03	Maintenance and repair of automobiles

7.0 Gap Analysis and Mitigation

Sl. No	Delivery Type	Details
01	Practical	Topic: Assembly of all automobile components

8.0 Books Used and Recommended to Students**Text Books**

1. **Automotive mechanics**, William H Crouse & Donald L Anglin, 10th Edition Tata McGraw Hill Publishing Company Ltd., 2007
2. **Automotive Mechanics**, S. Srinivasan, Tata McGraw Hill 2003.

Reference Books

1. **Automotive mechanics: Principles and Practices**, Joseph Heitner, D Van Nostrand Company, Inc
2. **Fundamentals of Automobile Engineering**, K.K.Ramalingam, Scitech Publications (India) Pvt. Ltd.
3. **Automobile Engineering**, R. B. Gupta, Satya Prakashan, 4th edn. 1984.
4. **Automobile engineering**, Kirpal Singh. Vol I and II 2002.

Additional Study material & e-Books

http://www.vssut.ac.in/lecture_notes/lecture1428910741.pdf

9.0 Relevant Websites (Reputed Universities and Others) for Notes/Animation/Videos Recommended**Website and Internet Contents References**

- http://www.bradford.ac.uk/timetabling/timetables/ei/mechanical-and-automotive-engineering-beng-meng/BEng_MEEng-Mechanical-Engineering-2016-17.pdf
- http://www.vssut.ac.in/lecture_notes/lecture1428910741.pdf
- <http://www.mechanicalgeek.com/wp-content/uploads/2016/11/ME2354-AE.pdf>

10.0 Magazines/Journals Used and Recommended to Students

SL.No	Magazines/Journals	website
1	SAE	http://magazine.sae.org/jnlauto/
2	IAME	http://www.iame.com.au/
3	AD&P BLOG	http://www.adandp.media/
4	Automotive Engineering	http://www.freetrademagazines.com/automotive-engineering-magazine/automotive-magazines/



11.0 Examination Note

Internal Assessment: 40 Marks

Theoretical aspects as well as relevant sketches should be drawn neatly for questions asked in Internal Assessments

Scheme of Evaluation for Internal Assessment

Internal Assessment test in the same pattern as that of the main examination (Better of the two Tests):20marks.

SCHEME OF EXAMINATION:

There are five modules two questions from each module

Student has to answer any five question choosing at least one questions from each module.

Max. Marks: 60Marks

12.0 Course Delivery Plan

Module No.	Lecture No.	Content of Lecture	% of Portion
1	1	Spark Ignition (SI) & Compression Ignition (CI) engines, cylinder – arrangements and their relatives merits,	23.80
	2	Liners, Piston, connecting rod, crankshaft, valves, valve actuating mechanisms,	
	3	valve and port timing diagrams, Types of combustion chambers for S.I.Engine and C.I.Engines,	
	4	Methods of a Swirl generation, choice of materials for different engine components, engine positioning.	
	5	Concept of HCCI engines, hybrid engines, twin spark engine, electric car.	
	6	COOLING AND LUBRICATION: cooling requirements, types of cooling-	
	7	thermo siphon system, forced circulation water cooling system,	
	8	Water pump, Radiator, thermostat valves.	
	9	Significance of lubrication, splash and	
	10	forced feed system	
2	11	Clutch-types and construction, gear boxes- manual and automatic,	19.05
	12	gear shift mechanisms, Over drive, transfer box, fluid flywheel,	
	13	torque converter, propeller shaft, slip joints, universal joints ,	
	14	Differential and rear axle, Hotchkiss Drive and Torque Tube Drive.	
	15	Types of brakes, mechanical compressed air, vacuum and hydraulic braking systems,	19.05
	16	construction and working of master and wheel cylinder, brake shoe arrangements,	
	17	Disk brakes, drum brakes, Antilock –Braking systems, purpose and operation of antilock-braking system,	
	18	ABS Hydraulic Unit, Rear-wheel antilock & Numerical	
3	19	STEERING AND SUSPENSION SYSTEMS: Steering geometry and types of steering gear box-Power Steering,.	19.05
	20	Types of Front Axle, Suspension, Torsion bar suspension systems,	
	21	Leaf spring, coil spring,	
	22	Independent suspension for front wheel and rear wheel,	
	23	Air suspension system	
	24	IGNITION SYSTEM: Battery Ignition system,	
	25	Magneto Ignition system,	
26	Electronic Ignition system		
4	27	SUPERCHARGERS AND TURBOCHARGERS: Naturally aspirated engines,	19.05
	28	Forced Induction, Types of superchargers,	



	29	Turbocharger construction and operation, Intercooler, Turbocharger lag.			
	30	27 FUELS, FUEL SUPPLY SYSTEMS FOR SI AND CI ENGINES: Conventional fuels, alternative fuels,			
	31	normal and abnormal combustion, cetane and octane numbers,			
	32	Fuel mixture requirements for SI engines, types of carburetors,			
	33	C.D.& C.C. carburetors, multi point and single point fuel injection systems, fuel transfer pumps,			
	34	Fuel filters, fuel injection pumps and injectors. Electronic Injection system, Common Rail Direct Injection System.			
	5	35		AUTOMOTIVE EMISSION CONTROL SYSTEMS: Different air pollutants, formation of photochemical smog and causes.	19.05
		36		Automotive emission controls, Controlling crankcase emissions, Controlling evaporative emissions,	
37		Cleaning the exhaust gas, Controlling the air-fuel mixture,			
38		Controlling the combustion process, Exhaust gas recirculation,			
39		Treating the exhaust gas, Air-injection system,			
40		Air-aspirator system, Catalytic converter.			
41		EMISSION STANDARDS: Euro I, II, III and IV norms,			
42		Bharat Stage II, III, IV norms. Motor Vehicle Act			

13.0 Assignments, Pop Quiz, Mini Project, Seminars

Sl.No.	Title	Outcome expected	Allied study	Week No.	Individual / Group activity	Reference: book/website /Paper
1	Assignment 1: Questions on engine components and cooling & lubrication systems:	Sketch and write the Answers.	Unit 1	2	Individual Activity.	Reference Book-3,4
2	Assignment 2: questions on transmission systems and brakes:	With neat sketch and explanation.	Unit 2	6	Individual Activity.	Reference Book-3,4
3	Assignment 3: Questions on steering and suspension systems ignition system:	Sketch and write the Answers.	Unit 3	8	Individual Activity.	Reference Book-3,4
4	Assignment 4: Questions on fuels, fuel supply systems for SI and CI engines superchargers and turbochargers:	Sketch and write the Answers.	Unit 4	10	Individual Activity.	Reference Book-3,4
5	Assignment 5: Questions on emission standards automotive emission control systems:	Explain the given questions	Unit 5	12	Individual Activity.	Reference Book-3,4

**14.0 QUESTION BANK****MODULE – 1: ENGINE COMPONENTS AND COOLING & LUBRICATION SYSTEMS:**

1. With a neat labeled diagram explain Spark Ignition (SI)
2. How does valve actuating mechanism work?
3. Explain with neat diagrams valve and port timing diagrams
4. What are different types of combustion chambers of S. I. Engine?
5. What is compression ratio? Explain briefly.
6. Write a note on engine positioning.
7. Why engines are need to be cooled? And what are different methods of cooling.
8. With line diagram explain different lubrication arrangements.

MODULE – 2: TRANSMISSION SYSTEMS AND BRAKES:

1. Draw a neat diagram for general arrangement of clutch
2. What is the principle behind friction clutches?
3. With a neat diagram explain Fluid flywheel
4. Explain with neat sketch Single plate, multi-plate and centrifugal clutches.
5. What is necessity for gear ratios in transmission?
6. Explain planetary gears systems.
7. Write a note on torque converters
8. What are principles of automatic transmission?
9. List all the formulae which are involved in calculation of gear ratios and torque transmission by clutches.
10. What are different types of brakes?
11. With a neat sketch Explain briefly hydraulic braking system.
12. Explain with a neat sketch construction and working of master and wheel cylinder.
13. With a neat sketch explain working of drum brakes
14. What is the purpose and operation of antilock-braking system?
15. Explain Hotchkiss and torque tube drives
16. What are different arrangements of fixing the wheels to rear axle?

MODULE – 3: STEERING, SUSPENSION SYSTEMS AND IGNITION SYSTEM:

1. Explain steering geometry.
2. Explain the followings camber, king pin inclination, included angle, castor, toe in & toe out.
3. What are the condition for exact steering
4. Write a note on power steering
5. What is over steer, under steer and neutral steer? numerical
6. What are requirements of Torsion bar suspension systems?
7. What is Air suspension system?.
8. Explain the following ignition systems
Battery Ignition system
Magneto Ignition system
9. How exactly electronic ignition system work?
10. What is automatic ignition?
11. Write a note on advance ignition systems.

MODULE – 4: FUELS, FUEL SUPPLY SYSTEMS FOR SI AND CI ENGINES, SUPERCHARGERS AND TURBOCHARGERS:

1. What alternative fuels can be used for IC engines?
2. What is normal and abnormal combustion?
3. Explain cetane and octane numbers.
4. What are different types of carburetors? Explain them with a neat sketch.
5. Explain multi point and single point fuel injection systems
6. How does Fuel filter work?
7. Write a note on fuel injection pumps.
8. What are naturally aspirated engines?
9. What is Forced Induction?
10. What are different types of superchargers?
11. With a neat labeled diagram explain turbocharger construction and operation
12. Why inter cooling is necessary?

MODULE – 5: EMISSION STANDARDS AUTOMOTIVE EMISSION CONTROL SYSTEMS:

1. How do you control crankcase emissions?
2. How do you control evaporative emissions?



S J P N Trust's

Hirasugar Institute of Technology, Nidasoshi

Inculcating Values, Promoting Prosperity

Approved by AICTE, Recognized by Govt. of Karnataka and Affiliated to VTU Belagavi.

Accredited at 'A' Grade by NAAC

Programmes Accredited by NBA: CSE, ECE, EEE & ME.

MECH.ENGG

Course Plan

VI (A&B)



2019-20 (Even)

3. How the air-fuel mixture is controlled?
4. With a neat sketch explain Exhaust gas recirculation.
5. Write a note on Air-injection system
6. What are Catalytic converters?
7. Explain Emission standards- Euro I, II, III and IV norms, Bharat Stage II, III norms.

15.0

University Result

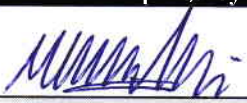
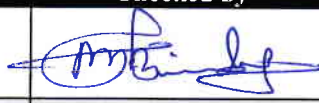
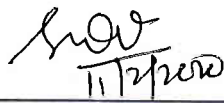
Examination	S ⁺	S	A	B	C	D	E	F	% Passing
June/July 2019	-	2	17	41	36	16	9	1	98.37

Prepared by	Checked by		
			
Prof. M.R.Ingalagi	Prof. A M Biradar	HOD	Principal



S J P N Trust's
Hirasugar Institute of Technology, Nidasoshi.

Inculcating Values, Promoting Prosperity
 Approved by AICTE, Recognized by Govt. of Karnataka, Affiliated to VTU Belagavi
 Accredited at 'A' Grade by NAAC
 Programmes Accredited by NBA: CSE, ECE, EEE & ME.

Mech. Engg.

Course Plan

VI (A&B)

2019-20 (Even)

Subject Title	TOTAL QUALITY MANAGEMENT		
Subject Code	17ME664	IA Marks	40
No of Lecture Hrs + Practical Hrs / Week	03	Exam Marks	60
Total No of Lecture + Practical Hrs	40	Exam Hours	03
CREDITS – 03			

FACULTY DETAILS:

Name: Prof. S R Kulkarni	Designation: Asst. Professor	Experience: 12 Years 06 Months
No. of times course taught: 03	Specialization: Production Management	
Name: Prof. Kushal Ambli	Designation: Asst. Professor	Experience: 06 Years
No. of times course taught: 01	Specialization: Product Design & Manufacturing	

1.0 Prerequisite Subjects:

Sl. No	Branch	Semester	Subject
1	Mechanical Engineering	V	Management & Entrepreneurship

2.0 Course Objectives

1. Understand various approaches to TQM
2. Understand the characteristics of quality leader and his role.
3. Develop feedback and suggestion systems for quality management.
4. Enhance the knowledge in Tools and Techniques of quality management

3.0 Course Outcomes

The student, after successful completion of the course, will be able to

CO	Course Outcome	Cognitive	POs
C327.1	Explain the various approaches of TQM and QMS.	L1,L2	1,5,6,11,12
C327.2	Identify the role of leader & leadership styles which helps for their future.	L2,L3	1,5,6,11,12
C327.3	Explain the methods to satisfy the customer, employee involvement and motivation techniques.	L2,L3	1,5,6,11,12
C327.4	Apply statistical tools for continuous improvement of quality systems	L2,L3	1,5,6,11,12
C327.5	Apply the tools and technique for effective implementation of TQM	L2,L3	1,5,6,11,12
Total Hours of instruction			40

4.0 Course Content

Module - 1

Principles and Practice: Definition, basic approach, gurus of TQM, TQM Framework, awareness, defining quality, historical review, obstacles, benefits of TQM. Quality Management Systems: Introduction, benefits of ISO registration, ISO 9000 series of standards, ISO 9001 requirements. **08 Hours**

Module - 2

Leadership: Definition, characteristics of quality leaders, leadership concept, characteristics of effective people, ethics, the Deming philosophy, role of TQM leaders, implementation, core values, concepts and framework, strategic planning communication, decision making. **08 Hours**



Module - 3

Customer Satisfaction and Customer Involvement:

Customer Satisfaction: customer and customer perception of quality, feedback, using customer complaints, service quality, translating needs into requirements, customer retention, case studies. Employee Involvement – Motivation, employee surveys, empowerment, teams, suggestion system, recognition and reward, gain sharing, performance appraisal, unions and employee involvement, case studies. **08Hours**

Module - 4

Continuous Process Improvement: process, the Juran trilogy, improvement strategies, types of problems, the PDSA Cycle, problem-solving methods, Kaizen, reengineering, six sigma, case studies.

Statistical Process Control : Pareto diagram, process flow diagram, cause and effect diagram, check sheets, histograms, statistical fundamentals, Control charts, state of control, out of control process, control charts for variables, control charts for attributes, scatter diagrams, case studies. **08 Hours**

Module - 5

Tools and Techniques: Benching marking, information technology, quality management systems, environmental management system, and quality function deployment, quality by design, failure mode and effect analysis, product liability, total productive maintenance. **08 Hours**

5.0 Relevance to future subjects/Area

SL. No	Semester	Subject	Topics / Relevance
1	8	Operations management	Problem solving skills
2	7	Human resource management	HRM Skills

6.0 Relevance to Real World

SL. No	Real World Mapping
01	Industry, Educational institutions, Public and Private sectors and Government Organizations

7.0 Books Used and Recommended to Students

Text Books
1.Total Quality Management: Dale.H.Bester field, Publisher- Pearson Education India, ISBN:8129702606
2.Total Quality management for Engineers: M. Zairi, ISBN- 1855730243 Publisher- Wood head publishing
Reference Books
1. Managing for Quality and Performance Excellence by James R.Evans and Willium M Lindsay, 9th edition, Publisher Cengage Learning.
2 A New American TQM, four revolutions in management, Shoji Shiba, Alan Graham, David Walden, Productivity press, Oregon, 1990
3.Organizational Excellence through TQM, H. Lal, New age Publications, 2008
Additional Study material & e-Books
<ul style="list-style-type: none"> • Nptel.ac.in • VTU, E-learning • MOOCs • Open course ware

8.0 Relevant Websites (Reputed Universities and Others) for Notes/Animation/Videos Recommended

Website and Internet Contents References
<ul style="list-style-type: none"> • http://www.nptel.ac.in



Course Plan
VI (A&B)
2019-20 (Even)

9.0 Magazines/Journals Used and Recommended to Students

Sl.No	Magazines/Journals	website
1	International Journal for Quality Research	www.ijqr.net/journal/v4-n2/8.pdf
2	Emerald The TQM Journal information - Emerald Group Publishing	www.emeraldgrouppublishing.com/tqm.htm

10.0 Examination Note

Internal Assessment: 40 Marks

Theoretical aspects as well as relevant sketches should be drawn neatly for questions asked in Internal Assessments

Scheme of Evaluation for Internal Assessment

Internal assessment test in the same pattern as that of the main examination (Average of three tests) 30 Marks.

Assignment Marks: 10

Total Internal Marks: 40

SCHEME OF EXAMINATION:

There are five modules two questions from each module

Student has to answer any five question choosing at least one questions from each module.

Max. Marks: 100 Marks

11.0 Course Delivery Plan

Unit No.	Lecture No.	Content of Lecture	% of Portion
1	1	Principles And Practices: Definition, basic approach,	20% (8 Hrs)
	2	Gurus of TQM,	
	3	TQM Framework, Awareness of TQM	
	4	Defining quality, historical review,	
	5	Obstacles, benefits of TQM	
	6	Quality Management Systems: Introduction, benefits of ISO registration	
	7	ISO 9000 series of standards,	
	8	ISO 9001 requirements.	
2	9	Leadership: Definition, characteristics of quality leaders.	40% (8 Hrs)
	10	Leadership concept, characteristics of effective people	
	11	Ethics	
	12	Deming philosophy, role of TQM leaders.	
	13	Implementation, core values,	
	14	concepts and frame work Strategic planning,	
	15	communication,	
	16	decision making	
3	17	Customer satisfaction and employee involvement:	60% (8 Hrs)
	18	Customer Satisfaction: customer and customer perception of quality,	
	19	Feedback, using customer complaints, service quality,	
	20	Translating needs into requirements, customer retention, and case studies.	
	21	Employee Involvement: Motivation, employee surveys empowerment.	
	22	Teams, suggestion system,	
	23	recognition and reward	
	24	Gain sharing, performance appraisal	
4	25	Continuous Process Improvement: process, Juran Trilogy, improvement strategies	80% (8Hrs)
	26	Types of problems, PDSA cycle,	
	27	Problem solving methods, Kaizen, Reengineering, Six sigma, case studies.	



**S J P N Trust's
Hirasugar Institute of Technology, Nidasoshi.**

Inculcating Values, Promoting Prosperity
Approved by AICTE, Recognized by Govt. of Karnataka, Affiliated to VTU Belagavi
Accredited at 'A' Grade by NAAC
Programmes Accredited by NBA: CSE, ECE, EEE & ME.

Mech. Engg.

Course Plan

VI (A&B)

2019-20 (Even)

5	28	Statistical Process Control : Pareto diagram, process flow diagram	100% (8 Hrs)
	29	cause and effect diagram, check sheets, histograms,	
	30	statistical fundamentals, Control charts, state of control, out of control process,	
	31	control charts for variables, control charts for attributes	
	32	Scatter diagrams, case studies	
	33	Tools and Techniques: Benchmarking, information technology,	
	34	Quality management systems,	
	35	environmental management system,	
	36	quality function deployment	
	37	Quality by design,	
	38	failure mode and effect analysis,	
	39	Product liability	
40	Total productive maintenance		

12.0 Assignments, Pop Quiz, Mini Project, Seminars

Sl.No.	Title	Outcome expected: students able to	Allied study	Week No.	Individual / Group activity	Reference: book/website /Paper
1	<i>Assignment -1:</i> Principles and Practice & QMS	Explain the various approaches of TQM and QMS.	Module 1	2	Individual Activity.	Text Book
2	<i>Assignment-2:</i> Leadership	Identify the role of leader & leadership styles which helps for their future.	Module 2	4	Individual Activity.	Text Book
3	<i>Assignment-3:</i> Customer Satisfaction and Customer Involvement	Explain the methods to satisfy the customer, employee involvement and motivation techniques.	Module 3	6	Individual Activity.	Text Book
4	<i>Assignment-4:</i> Continuous Process Improvement	Apply statistical tools for continuous improvement of quality systems	Module 4	8	Individual Activity.	Text Book
5	<i>Assignment-5:</i> Tools and Techniques	Apply the tools and technique for effective implementation of TQM	Module 5	10	Individual Activity.	Text Book

13.0 Question Bank

Sample Questions	Questions
I	Module 1 1. Explain TQM frame work with the help of neat sketch. 2. Define quality and explain contributions of gurus of TQM 3. List out six basic concepts of TQM and briefly explain them. 4. List out tangible and intangible benefits of TQM. 5. Discuss ISO 9000 and ISO 9001 Series of standards.
II	Module 2 1. List & Explain the characteristics of Quality Leaders 2. Briefly explain the seven steps to strategic planning. 3. Why quality council is established? What are the duties of quality council? 4. Explain in brief i) Vision Statement ii) Mission Statement iii) Quality Policy 5. List out seven characteristics or habits of effective people.



S J P N Trust's
Hirasugar Institute of Technology, Nidasoshi.

Inculcating Values, Promoting Prosperity
Approved by AICTE, Recognized by Govt. of Karnataka, Affiliated to VTU Belagavi
Accredited at 'A' Grade by NAAC
Programmes Accredited by NBA: CSE, ECE, EEE & ME.

Mech. Engg.

Course Plan

VI (A&B)

2019-20 (Even)

III	Module 3 1. Who is a customer? What is his role in developing organization? 2. What actions organization takes to handle customer complaints? 3. Define the term team? Why team work? 4. Define customer, what are the two types of customer. Explain with an example. 5. How does employee involvement can assist in growth of an organization?
IV	Module 4 1 Explain Juran Trilogy with a neat sketch. 2 Explain the concept of quality function deployment. 3 List and explain 7 tools of Quality and benefits of QFD. 4 Explain the process of Re-engineering, Kaizen and its benefits and applications 5 Discuss the meaning of Six Sigma and as a tool to improve the quality and 5S Principles. 6 Discuss the process of Bench marking and its advantages 7 Write a short note on control charts for variables and attributes.
V	Module 5 1 What is bench marking? Explain. 2 Write a note on QMS and EMS 3 What is QFD? Explain the house of quality with neat sketch. 4 Discuss quality by design and TPM concepts. 5 With an example explain FMEA concept.

15.0 University Result

Examination	S+	S	A	B	C	D	E	% Passing
2018-19	--	07	22	19	11	1	0	100
2017-18	--	6	18	19	16	1	--	98

Examination	FCD	FC	SC	% Passing
2016/17	15	34	48	100
2015/16	38	54	24	100

Prepared by	Checked by		
Prof. K. G Ambli	Prof. S. R. Kulkarni	HOD	Principal

1/2

2/3



Subject Title	HEAT TRANSFER LAB		
Subject Code	17MEL67	IA Marks	40
L-T-P	1-0-2	Exam Marks	60
Total No of Lecture + Practical Hrs	40	Exam Hours	03
			CREDITS – 02

FACULTY DETAILS:

Name: Dr. K. M. Akkoli	Designation: Assistant Professor	Experience : 16
No. of times course taught: 10 Times	Specialization: Thermal Power Engineering	
Name : Prof. M.M. Shivashimpi	Designation: Assistant Professor	Experience : 12
No. of times course taught: 04 Times	Specialization: Thermal Power Engineering	
Name: Prof. M.R. Ingalagi	Designation: Asst. Professor	Experience : 07
No. of times course taught: 02 Times	Specialization: Thermal Power Engineering	

1.0 Prerequisite Subjects:

SL. No.	Branch	Semester	Subject
01	Mechanical Engineering	I	Engineering Physics
02	Mechanical Engineering	III	Basic Thermodynamics
03	Mechanical Engineering	IV	Fluid Mechanics
04	Mechanical Engineering	VI	Heat & Mass Transfer

2.0 Course Objectives

1. The primary objective of this course is to provide the fundamental knowledge necessary to understand the behavior of thermal systems.
2. This course provides a detailed experimental analysis, including the application and heat transfer through solids, fluids, and vacuum. Convection, conduction, and radiation heat transfer in one and two dimensional steady and unsteady systems are examined.

3.0 Course Outcomes

The student, after successful completion of the course, will be able to

CO	Course Outcome	Cognitive Level	POs
C328.1	Perform experiments to determine the thermal conductivity of a metal rod	L5	PO1, PO2, PO9, PO12
C328.2	Conduct experiments to determine convective heat transfer coefficient for free and forced convection and correlate with theoretical values.	L5	PO1, PO2, PO9, PO12
C328.3	Estimate the effectiveness and efficiency in pin-fin pin-fin	L5	PO1, PO2, PO9, PO12
C328.4	Determine the emissivity of the given test plate and Prove Stefan Boltzmann law of radiation.	L4	PO1, PO2, PO9, PO12
C328.5	Conduct and measure the overall heat transfer coefficient, effectiveness of parallel and counter flow heat exchangers.	L5	PO1, PO2, PO9, PO12
C328.6	Estimate the heat transfer coefficient for film wise and drop wise condensation processes.	L5	PO1, PO2, PO9, PO12
C328.7	Demonstrate the working of Refrigeration and Air-conditioning system.	L5	PO1, PO2, PO9, PO12
C328.8	Calculate temperature distribution of study and transient heat conduction through plane wall, cylinder and fin using numerical approach.	L5	PO1, PO2, PO5, PO9, PO12
Total Hours of instruction			40

**4.0 Course Content****PART – A**

1. Determination of Thermal Conductivity of a Metal Rod.
2. Determination of Overall Heat Transfer Coefficient of a Composite wall.
3. Determination of Effectiveness on a Metallic fin.
4. Determination of Heat Transfer Coefficient in a free Convection on a
5. Determination of Heat Transfer Coefficient in a Forced Convection Flow through a Pipe.
6. Determination of Emissivity of a Surface.
7. Analysis of steady and transient heat conduction, temperature distribution of plane wall and cylinder using Numerical approach (ANSYS/CFD package).

PART – B

1. Determination of Steffan Boltzmann Constant.
2. Determination of LMDT and Effectiveness in a Parallel Flow and Counter Flow Heat Exchangers.
3. Experiments on Boiling of Liquid and Condensation of Vapour.
4. Performance Test on a Vapour Compression Refrigeration.
5. Performance Test on a Vapour Compression Air – Conditioner.
6. Experiment on Transient Conduction Heat Transfer.
7. Determination of temperature distribution along a rectangular and circular fin subjected to heat loss through convection using Numerical approach (ANSYS/CFD package)

5.0 Relevance to future subjects

SL. No.	Semester	Subject	Topics / Relevance
01	III / IV & VI	BTD, ATD & HMT	Provides basics of Laws and understanding the theory
02	VIII	Project work	Innovations and modifications of projects related to Heat & Mass transfer

6.0 Relevance to Real World

SL. No.	Real World Mapping
01	Designing the heat exchangers, air conditioners, air compressors and furnaces for the industries
02	Study the properties of materials used in industries
03	Radiators

7.0 Books Used and Recommended to Students**Reading Books**

1. M. Necati Ozisik, Heat Transfer – A Basic Approach, McGraw Hill, New York, 2005.
2. Incropera, F. P. and De Witt, D. P., Fundamentals of Heat and Mass Transfer, 5th Edition, John Wiley and Sons, New York, 2006.
3. Holman, J. P., Heat Transfer, 9th Edition, Tata McGraw Hill, New York, 2008.

Additional Study Books

1. Power plant Engineering by E Wakil.
2. Solar Energy By Sukhatme.
3. Heat and Mass Transfer By P K Nag.
4. Principles of heat transfer by Kreith Thomas Learning 2001.

8.0 Relevant Websites (Reputed Universities and Others) for Notes/Animation/Videos Recommended**Website and Internet Contents References**

1. <http://www.nptel.ac.in>
2. https://en.wikipedia.org/wiki/Heat_transfer
3. nptel.ac.in/courses/112104116/



S J P N Trust's

Hirasugar Institute of Technology, Nidasoshi

Inculcating Values, Promoting Prosperity

Approved by AICTE, Recognized by Govt. of Karnataka and Affiliated to VTU Belagavi.

Accredited at 'A' Grade by NAAC

Programmes Accredited by NBA: CSE, ECE, EEE & ME.

MED

Course Plan

VI (A&B)

2019-20 (Even)

9.0

Magazines/Journals Used and Recommended to Students

Sl. No.	Magazines/Journals	website
1	International Journal of Heat transfer	https://www.journals.elsevier.com/international-journal-of-heat-and-mass-transfer/
2	International Journal of Thermodynamics	http://dergipark.ulakbim.gov.tr/eoguijt/

10.0

Examination Note

Scheme of Examination:

ONE question from part -A: 50 Marks

ONE question from part -B: 30 Marks

Viva –Voice: 20 Marks

Total: 100 Marks

11.0

Course Delivery Plan

Expt. No	Lecture / Practical No	Name of the Experiment	% Of Portion
PART-A			
1	1	Determination of Thermal Conductivity of a Metal Rod.	47.61
2	2	Determination of Overall Heat Transfer Coefficient of a Composite wall.	
3	3	Determination of Effectiveness on a Metallic fin.	
4	4	Determination of Heat Transfer Coefficient in a free Convection on a vertical tube.	
5	5	Determination of Heat Transfer Coefficient in a Forced Convection Flow through a Pipe.	
6	6	Determination of Emissivity of a Surface.	
7	7	Analysis of steady and transient heat conduction, temperature distribution of plane wall and cylinder using Numerical approach (ANSYS/CFD package).	
PART-B			
8	8	Determination of Steffan Boltzmann Constant.	52.33
9	9	Determination of LMDT and Effectiveness in a Parallel Flow and Counter Flow Heat Exchangers.	
10	10	Experiments on Boiling of Liquid and Condensation of Vapour.	
11	11	Performance Test on a Vapour Compression Refrigeration.	
12	12	Performance Test on a Vapour Compression Air – Conditioner.	
13	13	Experiment on Transient Conduction Heat Transfer.	
14	14	Determination of temperature distribution along a rectangular and circular fin subjected to heat loss through convection using Numerical approach (ANSYS/CFD package).	

12.0

QUESTION BANK

1. Define and explain the different modes of heat transfer.
2. State laws concerned three modes of heat transfer.
3. Give the classification of heat exchangers based on flow and mode of heat exchanger.
4. Derive an expression for LMTD for a Parallel and Counter flow heat exchanger.
5. Derive an expression for Effectiveness for a Parallel and Counter flow heat exchanger.
6. List the assumptions made in the derivation of the Film Condensation theory.
7. Differentiate between drop-wise and film-wise condensation process.
8. Explain the following laws as applied to radiation: i) Stefan Boltzman law ii) Plank's Distribution law iii) Wein's Displacement law iv) Kirchoff's law.



S J P N Trust's

Hirasugar Institute of Technology, Nidasoshi

Inculcating Values, Promoting Prosperity
Approved by AICTE, Recognized by Govt. of Karnataka and Affiliated to VTU Belagavi.

Accredited at 'A' Grade by NAAC

Programmes Accredited by NBA: CSE, ECE, EEE & ME.

MED

Course Plan

VI (A&B)

2019-20 (Even)

9. Define the terms Critical thickness of insulation, Fin efficiency, Contact and thermal resistances.
10. Explain the following Dimensionless number and their physical significance: (i) Reynolds number, (ii) Prandtl number, (iii) Nusselt number.
11. Define the terms Critical thickness of insulation, Fin efficiency, Contact and thermal resistances.

13.0 University Result

Examination	S+	S	A	B	C	D	E	% Passing
June_July 2019	23	67	19	2	9	2	0	99.19
May_June 2018	30	51	32	3	0	0	0	99.19

Prepared by	Checked by		
Prof. M. M. Shivashimpi Prof. M.R. Ingalagi	Dr. K. M. Akkoli	HOD	Principal



Subject Title	MODELING AND ANALYSIS LAB		
Subject Code	17MEL68	IA Marks	40
No of Practical Hrs/ Week	03	Exam Marks	60
Total No of Practical Hrs		Exam Hours	03
CREDITS – 02			

FACULTY DETAILS:

Name: Mr. S. A. Goudadi	Designation: Asst. Professor	Experience: 12 Years
No. of times course taught: 01	Specialization: Design Engineering	

1.0 Prerequisite Subjects:

Sl. No	Branch	Semester	Subject
01	Mechanical Engineering	I/II/III/IV	Engg. Mathematics
02	Mechanical Engineering	III	Mechanics of Mechanics
03	Mechanical Engineering	VI	Design of Machine Elements-II
04	Mechanical Engineering	VI	Heat and Mass Transfer
05	Mechanical Engineering	VI	Finite Element Methods

2.0 Course Objectives

- To acquire basic understanding of Modeling and Analysis software
- To understand the different kinds of analysis and apply the basic principles to find out the stress and other related parameters of bars, beams loaded with loading conditions.
- To learn to apply the basic principles to carry out dynamic analysis to know the natural frequency of different kind of beams.

3.0 Course Outcomes

The student, after successful completion of the course, will be able to

CO	Course Outcome	Cognitive Level	POs	PSOs
C329.1	Demonstrate the basic features of an analysis package.	L1,L2,L3	1,2,3,5,6,8,11,12	1,2,3
C329.2	Use the modern tools to formulate the problem, and able to create geometry, discretize, apply boundary condition to solve problems of bars, truss, beams, plate to find stress with different loading conditions.	L1,L2,L3	1,2,3,5,6,8,11,12	1,2,3
C329.3	Demonstrate the deflection of beams subjected to point, uniformly distributed and varying loads further to use the available results to draw shear force and bending moment diagrams.	L1,L2,L3	1,2,3,5,6,8,11,12	1,2,3
C329.4	Analyze the given problem by applying basic principle to solve and demonstrate 1D and 2D heat transfer with conduction and convection boundary conditions.	L1,L2,L3	1,2,3,5,6,8,11,12	1,2,3
C329.5	Carry out dynamic analysis and finding natural frequencies for various boundary conditions and also analyze with forcing function.	L1,L2,L3	1,2,3,5,6,8,11,12	1,2,3

4.0 Course Content**PART - A****Study of a FEA package and modeling stress analysis of**

- Bars of constant cross section area, tapered cross section area and stepped bar
- Trusses – (Minimum 2 exercises of different types)
- Beams – Simply supported, cantilever, beams with point load, UDL, beams with varying load etc. (Minimum 6 exercises different nature).
- Stress analysis of a rectangular plate with circular hole.

**PART – B**

1. Thermal Analysis – 1D & 2D problem with conduction and convection boundary Conditions (Minimum 4 exercises of different types).
2. Dynamic Analysis
 - 1) Fixed – fixed beam for natural frequency determination
 - 2) Bar subjected to forcing function
 - 3) Fixed – fixed beam subjected to forcing function

PART – C

1. Demonstrate the use of graphics standards (IGES, STEP etc) to import the model from modeller to solver
2. Demonstrate one example of contact analysis to learn the procedure to carry out contact analysis.
3. Demonstrate at least two different type of example to model and analyze bars or plates made from composite material

5.0 Relevance to future subjects

SL. No	Semester	Subject	Topics / Relevance
01	VIII	Project work	Modeling and Analysis of components for project

6.0 Relevance to Real World

SL.No	Real World Mapping
01	Examples of bars, beams and Trusses
02	Examples of 1D bars for heat transfer

7.0 Books Used and Recommended to Students**Reference Books**

1. A first course in the Finite element method, Daryl L Logan, Thomason, Third Edition
2. Fundamentals of FEM, Hutton – McGraw Hill, 2004
3. Finite Element Analysis, George R. Buchanan, Schaum Series

Additional Study material & e-Books

1. NPTEL of FEM and FEA

8.0 Relevant Websites (Reputed Universities and Others) for Notes/Animation/Videos Recommended**Website and Internet Contents References**

- 1) https://en.wikipedia.org/wiki/Finite_element_method
- 2) nptel.ac.in/courses/112104116/

9.0 Magazines/Journals Used and Recommended to Students

Sl.No	Magazines/Journals	website
1	International Journal of Computational Methods	www.worldscientific.com
2	International Journal of Solids and Structures	http://www.sciencedirect.com/science/journal/00207683

10.0 Examination Note**Internal Assessment:**

Theoretical aspects as well as relevant sketches should be drawn neatly for questions asked in Internal Assessments

Scheme of Evaluation for Internal Assessment (40 Marks)

- (a) Continuous assessment (lab conduction): 24 marks
- (b) Internal Assessment test in the same pattern as that of the main examination: 16 marks.



S J P N Trust's

Hirasugar Institute of Technology, Nidasoshi.*Inculcating values, Promoting Prosperity*

Approved by AICTE, Recognized by Govt. of Karnataka and Affiliated to VTU Belagavi.

Accredited at 'A' Grade by NAAC**Programmes Accredited by NBA: CSE, ECE, EEE & ME**

Mech. Engg. Dept.

Academic

Course Plan

2019-20(Even)

SCHEME OF EXAMINATION:

One Question from Part A - 40 Marks

One Question from Part B - 40 Marks

Viva-Voce - 20 Marks

Total - 100 Marks

11.0 Course Delivery Plan

Practical No	Name of the Experiment	% of Portion
01	Introduction to FEM and Analysis software	8.33
02	Analysis of rectangular plate with a hole.	8.33
03	Stress Analysis: Analysis of the simple bar of constant cross section area.	8.33
04	Analysis of the stepped bar.	8.33
05	Analysis of the tapered bar.	8.33
06	Analysis of two bar truss element for the nodal displacement and stress in each bar	8.33
07	Analysis of three bar truss element for the nodal displacement and stress in each element	8.33
08	Analysis of three bar truss element for the nodal displacement and stress in each element	8.33
09	To find the SFD and BMD for cantilever beam with point load.	8.33
10	To find the SFD and BMD for simply supported beam with UDL and point load	8.33
11	To find the SFD and BMD for simply supported beam with UDL	8.33
12	To determine the temperature at any point in the composite wall	8.33
13	Model analysis: Mode shapes & corresponding natural frequency for different models.	8.33

12.0 QUESTION BANK

- 01 What is FEM?
- 02 What are the applications of FEM in different fields?
- 03 What is node, element, shape function and discretization?
- 04 What are the different steps involved in the FEM?
- 05 What is the difference between isotropic orthotropic materials?
- 06 What is "H" method and "P"?
- 07 What are different types of elements?
- 08 What are the convergence requirement, compatibility requirement and geometric requirement?
- 09 Explain natural co-ordinate system.
- 10 What is static condensation?

Prepared by		
Mr. S. A. Goudadi	HOD	Principal